

29	804590508U	T/Screw (P.Head)	.	4	.	.	M5 x 8
28	H-002100-29	Cap	.	4	.	Daisho	H-03
27	K-502018	Holder	.	2	.	.	.
26	J-0020050	Caster ASSY	.	G1	.	.	.
25	K-503007	Cap	.	4	.	.	(70 x 30)
24	K-503003	Cap	.	8	.	.	(30 x 20)
23	K-501009	Cushion Rubber	.	2	.	.	.
22	K-501009	Cushion Rubber	.	2	.	.	.
21	K-500001	Roller	.	2	.	.	.
20	K-400004	Spring	.	A2	.	.	.
19	K-005020	Pin	.	B2	.	.	(#12 x 24)
18	K-005019	Pin	.	H4	.	.	(#8 x 41)
17	K-005019	Pin	.	B2	.	.	(#8 x 16)
16	K-000002	Dantsuki Bolt	.	D4	.	.	(L=17)
15	K-000001	Dantsuki Bolt	.	4	.	.	.
14	F-030010	Bottom Stopper	.	1	.	.	.
13	K-502014	Side Bumper ASSY	.	2	.	.	.
12	J-9010800	Foot Board ASSY	.	1	.	.	.
11	J-9010700	Head Board ASSY	.	1	.	.	.
10	J-9416000	Operating System ASSY	.	1	.	.	.
9	H-002040	Hi-Lo Rod COMPL	.	1	.	.	.
8	H-002030	Hi-Lo Torque Tube (F) COMPL	.	1	.	.	.
7	H-002020	Hi-Lo Torque Tube (H) COMPL	.	1	.	.	.
6	J-0020600	Bottom Center COMPL	.	1	.	.	.
5	J-0020500	Bottom (C) COMPL	.	1	.	.	.
4	J-0020400	Bottom (B) COMPL	.	1	.	.	.
3	J-0020300	Bottom (A) COMPL	.	1	.	.	.
2	J-9020200	Lower Frame COMPL	.	1	.	.	.
1	J-9010100	Main Frame COMPL	.	1	.	.	.

  

NO.	PART NO.	PART NAME	QTY	MATERIAL	MATERIAL DIMENSION/ NOTE
41	J-9010001	The grease application point	1	.	.
40	K-901039	Caution Label	1	.	.
39	803200500U	S/W	4	.	#5
38	K-901084	Manufacture Label	1	.	.
37	K-901038	Caution Label	1	.	.
36	K-901120	Marquis Bed Label	1	.	.
35	802230600U	Lock Nut	2	.	M6
34	804300640U	Screw T.Head	2	.	M6 x 40
33	80511200U	Snap Pin	2	.	#12
32	802250800U	Push Nut	6	.	SPN-8
31	803100800U	P/W	4	.	#8
30	802230800U	Lock Nut	4	.	M8

NO.	PART NO.	PART NAME	QTY	MATERIAL	MATERIAL DIMENSION/ NOTE
.	.	APPD.	CHECK :	EFFECTIVE DATE :	SURFACE TREATMENT :
.	.	.	.	28-09-2007	.
.	.	DESIGNED :	DRAWN :	SCALE :	MASS :
.	.	IVO A.	Donald	1/16	Lbf
.	.	M.Koyahara	ardith	APPL. STD.	.
MODEL :	PART NAME :	PART NO.	EC.	REV.	
M-3003D	3CR Hi-Lo GatchiBed ASSY	J-9420000	01	00	

JARAK CRANK BRACKET K-100032 DI PERLEBAR (AWAL 63 MENJADI 72) SUPAYA COVER PLASTIC BOSSAY MASUK

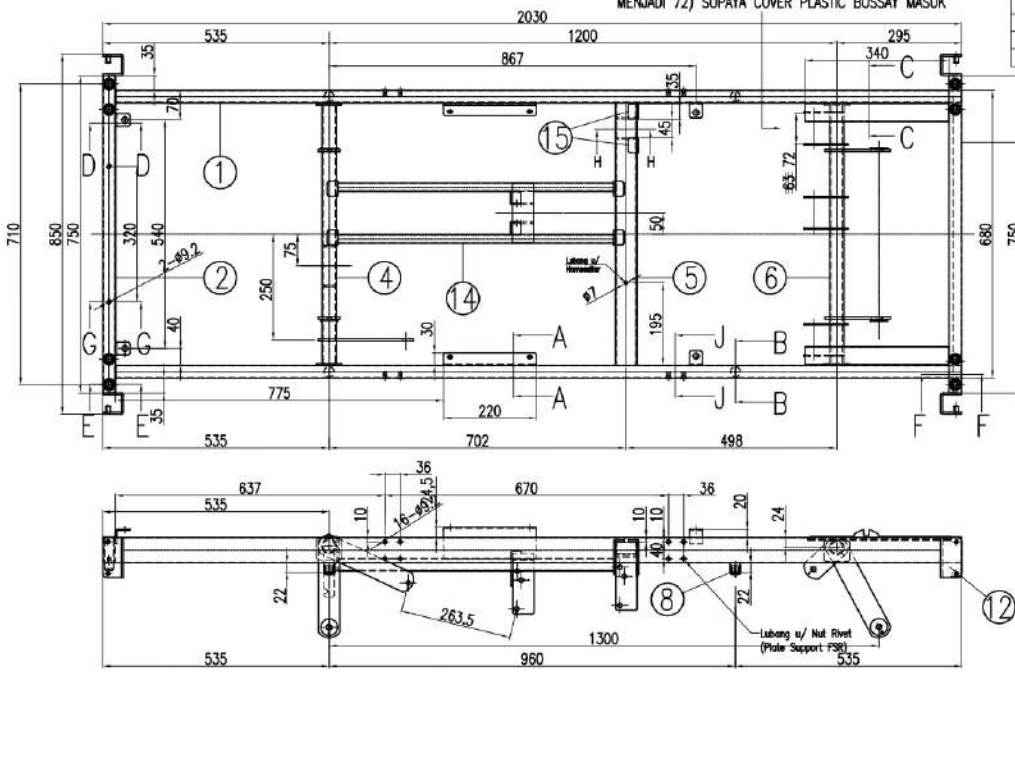

NO	CODE	COMPONENT	QTY	UNIT	COMPONENT SPECIFICATION
1	-	Side Frame	2	Pcs	Fp.60/30 x t 1.8 x 1998, STMM 11A
2	-	Cross Frame A (Head) Compl.	1	Pcs	Fp. 40/30 x t 1.8 x 750, STMM 11A
3	-	Cross Frame B (Foot) Compl.	1	Pcs	FL t 1.8 x 139 x 750, SPOC
4	-	Cross Member A Compl.	1	Unit	-
5	-	Cross Member B Compl.	1	Unit	-
6	-	Cross Member C Compl.	1	Unit	-
7	K-202048	Bracket Cooler	2	Pcs	FL 3.2 x 100 x 220, SPOC
8	-	Shopper Pipe	4	Pcs	Fp. 405.4 x t 1.2 x 22-00, STMM 11A
9	K-212005	Roller Support	2	Pcs	-
10	K-202048	Shopper Bracket	4	Pcs	-
11	K-30002	Holder	8	Pcs	-
12	K-212015	Hook Bracket	4	Pcs	-
13	-	Weld Nut	18	Pcs	M8
14	-	Bracket Frame Compl.	1	Unit	-
15	K-202061	Angle K	2	Pcs	FL t 4.5 x 35 x 90, SPOC-S0

CROSS FRAME FOOT DICANTI CROSS FRAME BARU

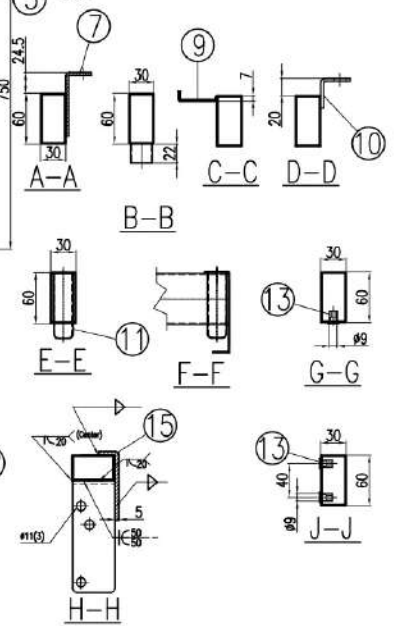

Client Application :				Specification :		MUR :		Unit :	Paper :	Scale :	Projection :	Drawing Name :
								mm	A4	1:X		Main Frame Compl.
Drawn :	Designed/ Customer :	Checked :	Approved :	Sketch :	Effective Date :	31-08-2023	Page :	1	PT.Chitose Internasional Tbk.		Product Name :	
[V/A/N]	CM	M.Royidin	M.Royidin	PREPARATION DRAWING	Production Date :				Research & Development Dept.		CB 3012/3003/3300	



K:\RND-136\shop\PRD\01\_GTRP\PROJECT\2023\BED KUPU2 MULTI\11\_BOTTOM B\_COMPL.dwg

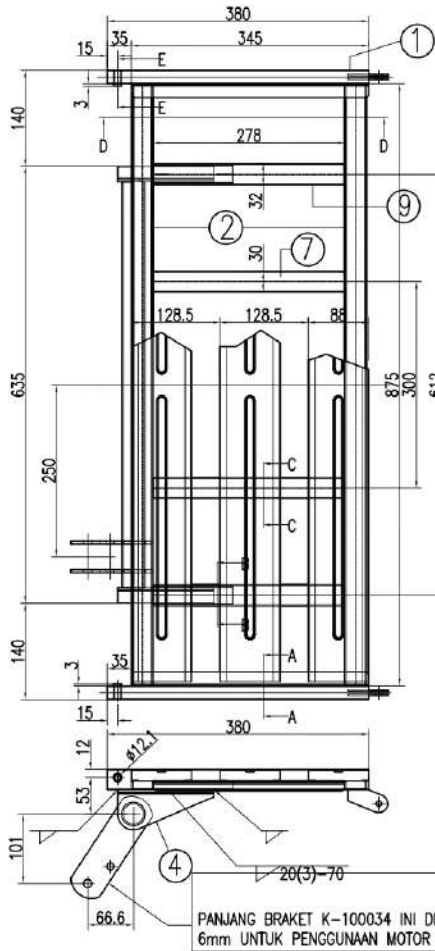

PANJANG BRACKET K-100034 INI DIKURANGIN 6mm UNTUK PENGGUNAAN MOTOR TIMOTON

NO	CODE	COMPONENT	QTY	UNIT	COMPONENT SPECIFICATION
1	J-0020410	Frame A	2	PCS	Pl. 30/20 x t 1.6 x 380 STKR
2	.	Plate Frame 32/12 C	2	PCS	Pl. t 2.0 x (48) x 875, SPHC
3	F-021200-2	Pipe / Collar	2	PCS	Ø12 x t 1.6 x 23 STKM 11A
4	H-002410	Torque Tube Compl.(modB)	1	Unit	-
5	E-022401	Angle E	E2	PCS	Pl. t 1.6 x 34 x 345 SPCC
6	K-200007	Hinge Plate	4	PCS	Pl. t 2.3 x 33 x 68 SPCC
7	K-202008	Frame N	N4	PCS	Pl. t 1.2 x 58 x 278 SPCC
8	K-202037	Suroko Plate A	A3	PCS	Pl. t 0.7 x (134) x 861 SPCC
9	.	Plate Frame 32/12 D	2	PCS	Pl. t 2.0 x (48) x 278, SPHC
10	.	Plate Support	2	PCS	Pl. t 9 x 25 x 115, SPHC

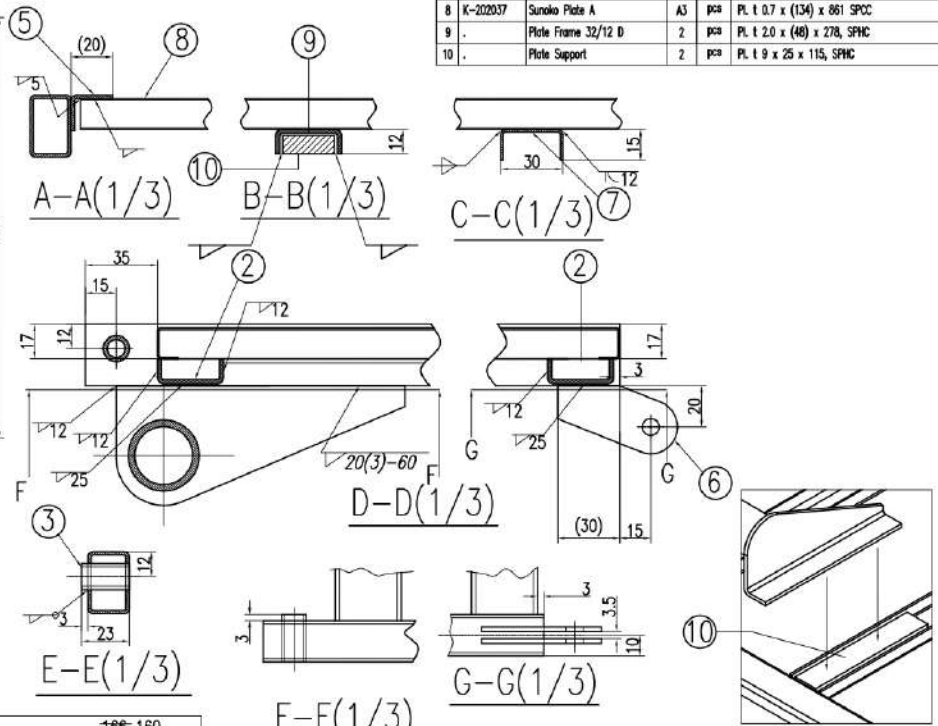

NO	DATE	REMARKS	DRAWN	CHECKED	APPROVED	REVISED BY
△						
△						
△						

Classif. Application :	Specification :	MEMO :	Unit :	Paper :	Scale :	Projection :	Drawing Name :
		INDOMEDIK OPTIMUS 3E	mm	A4	1:X		<b>BOTTOM B COMPL.</b>
Drawn : [V/M]	Designed/Customer : CM	Checked : M.Royidin	Approved : M.Royidin	Effective Date : 11-02-2023	Page : 11	PT.Chitose Internasional Tbk. Research & Development Dept.	Product Name : <b>CB-3012/3003/3300</b>
		PREPARATION DRAWING					
		PRODUCTION DRAWING					



**DAFTAR STANDAR KOMPONEN**

Formulir : R&D/DSKB/2023



KO: FG-NSB-NSB-AS-0011 (P IVORY)  
 TIP : CB 3003 D  
 NAI: 4 BOTTOM HI-LO GATCH BED  
 SIS: 3 COMPACT CRANK (Hi-Lo, Foot Raise, Back Raise)  
 CA: DOUBLE LOCK CASTER (SUNNY DIA.100mm)  
 HF : BD-001 (PENJABARAN SPESIFIKASI LIHAT DI BAGIAN DSKB ACCESSORIES)

No	Rank	Nama Komponen	Spesifikasi Komponen (mm)	Qty / Unit	Suplier + Sub Con	Asal	
						Lokal	Impor/ Alt.Impor
1		<b>Main Frame Compl</b>		1			
	1-1	<b>Side Frame (LH/RH) Compl</b>					
	1-1-1	Side Frame (LH/RH)	Pipa Kotak 70/30 x 1.9 x 2030 STKR	2 pcs	ISTW/Sri Rejeki + CIM	LOKAL	
	1-1-2	Holder C [K-300002C]	Pipa Bulat Ø22.2 x 1.0 x 85(78) STKM 11 A	14 pcs	ISTW/Sri Rejeki + Hinani	LOKAL	
	1-1-3	Stopper Bracket [K-202048]	Pl.t 3.2 x 30 x 63 SPHC	4 pcs	USC/SSI + Hinani	LOKAL	
	1-1-4	Hinge Bracket [K-112003]	Pl.t 6.0 x 32 x 80 SPHC	4 pcs	USC/SSI + Hinani	LOKAL	
	1-1-5	Braket Center [K-202049]	Pl.t 3.2 x 102 x 220 SPHC	2 pcs	USC/SSI + Rajawali	LOKAL	
	1-1-6	<b>Bracket Pin Compl K-212012</b>		2			
	1-6-1	PLATE K-212012-1	Pl.t 4.5 x 25 x 104 (SPHC)	2 pcs	USC/SSI + Hinani	LOKAL	
	1-6-2	Pin [K-005016]	Ø10 x Ø8 x 19.5 SS400	4 pcs	Rajawali	LOKAL	
	1-2	<b>Cross Frame Foot Side Compl</b>		2			
	1-2-1	Cross frame foot sid H-022101D (3 LBG)	Pl.t 1.6 x 139 x 750 SPCC	1 pcs	USC/SSI + Rajawali	LOKAL	
	1-2-2	<b>Bracket (R/L) K-110020</b>	<b>Assy Rajawali (Las)</b>	2			
	1-2-2-1	Hook Bracket [K-212015]	Pl.t 4.5 x 95 x 135 SPHC	2 pcs	USC/SSI + Hinani	LOKAL	
	1-2-2-2	Pin [K-005016]	Ø10 x Ø8 x 19.5 SS400	4 pcs	Rajawali	LOKAL	
	1-3	<b>Cross Member B Compl</b>		1			
	1-3-1	Cross Pipe	Pipa Bulat Ø34 x 2.6 x 841 STKM 11 A	1 pcs	ISTW/Sri Rejeki + CIM	LOKAL	
	1-3-2	Plate [F-030110-2]	Pl.t 4.5 x 50 x 60 SPHC	2 pcs	USC/SSI + Rajawali	LOKAL	
	1-3-3	Crank Bracket [K-100032]	Pl.t 3.2 x 50 x 120 SPHC	6 pcs	USC/SSI + Rajawali	LOKAL	
	1-3-4	<b>Bracket Compl K-110017</b>	<b>Assy Rajawali (Las)</b>	2			
	1-3-4-1	Bracket [K-110017]	Pl.t 6.0 x 50 x 262 SPHC	2 pcs	USC/SSI + Rajawali	LOKAL	

No	Rank	Nama Komponen	Spesifikasi Komponen (mm)	Qty / Unit		Suplier + Sub Con	Asal	
							Lokal	Impor/ Alt.Impor
	1-3-4-2	Plate [K-200003]	Pl.t 4.5 x Ø40 (OD) x Ø12.2 (ID) SPHC	2	pcs	USC/SSI + Rajawali	LOKAL	
<b>1-4</b>		<b>Cross Member A Compl</b>		<b>1</b>				
	1-4-1	Cross Pipe	Pipa Bulat Ø34 x 2.6 x 841 STKM 11 A	1	pcs	ISTW/Sri Rejeki + CIM	LOKAL	
	1-4-2	Plate [F-030110-2]	Pl.t 4.5 x 50 x 60 SPHC	2	pcs	USC/SSI + Rajawali	LOKAL	
	1-4-3	Stopper (R CUT) [H-002110-3]	Pipa Bulat Ø25.4 x 1.2 x 46 STKM 11 A	2	pcs	ISTW/Sri Rejeki + Rajawali	LOKAL	
	1-4-4	Bracket Hook [K-103004]	Pl.t 4.5 x 25 x 110.5 (SPHC)	2	pcs	USC/SSI + Rajawali	LOKAL	
<b>1-4-5</b>		<b>Bracket Compl [K-110016]</b>	<b>Assy Rajawali (Las)</b>	<b>2</b>				
	1-4-5-1	Bracket [K-110016]	Pl.t 6.0 x 50 x 242 SPHC	2	pcs	USC/SSI + Rajawali	LOKAL	
	1-4-5-2	Plate [K-200003]	Pl.t 4.5 x Ø40 (OD) x Ø12.2 (ID) SPHC	2	pcs	USC/SSI + Rajawali	LOKAL	
<b>1-5</b>		<b>Cross Frame A Center Compl</b>						
	1-5-1	Cross Frame A Center	Pipa Kotak 50/30 x 1.6 x 850 STKR	1	pcs	ISTW/Sri Rejeki + CIM	LOKAL	
	1-5-2	Stopper [H-002100-5]	Pipa Bulat Ø25.4 x 1.2 x 40 STKM 11 A	2	pcs	ISTW/Sri Rejeki + Rajawali	LOKAL	
1-6		Cross Frame A Head	Pipa Kotak 50/30 x 1.6 x 850 STKR	1	pcs	ISTW/Sri Rejeki + CIM	LOKAL	
1-7		Cross Frame Center BRKT (B)	Pipa Kotak 30/20 x 1.6 x 843 STKR	2	pcs	ISTW/Sri Rejeki + CIM	LOKAL	
1-8		Roller Support [K-212005 L]	Pl.t 1.6 x 70.6 x 340 SPCC	1	pcs	USC/SSI + Rajawali	LOKAL	
1-9		Roller Support [K-212005 R]	Pl.t 1.6 x 70.6 x 340 SPCC	1	pcs	USC/SSI + Rajawali	LOKAL	
<b>2</b>		<b>Lower Frame Compl</b>		<b>1</b>				
2-1		Lower Frame	Pipa Kotak 40/25 x 1.6 x 1437.5 STKR	2	pcs	ISTW/Sri Rejeki + CIM	LOKAL	
<b>2-2</b>		<b>Cross Frame Compl L</b>		<b>1</b>				
	2-2-1	Cross Frame	Pipa Bulat Ø34 x 2.6 x 656 STKM 11 A	1	pcs	ISTW/Sri Rejeki + CIM	LOKAL	
	2-2-2	End Plate [H-002200-3] ▶ (no.13)	Pl.t 4.5 x 44 x 57 SPHC	2	pcs	USC/SSI + Rajawali	LOKAL	
<b>2-2-3</b>		<b>Arm Compl</b>	<b>Assy Rajawali (Las)</b>	<b>2</b>				
	2-2-3-1	Arm [K-110018]	Pl.t 6.0 x 50 x 138 SPHC	2	pcs	USC/SSI + Rajawali	LOKAL	
	2-2-3-2	Plate [K-200003]	Pl.t 4.5 x Ø40 (OD) x Ø12.2 (ID) SPHC	2	pcs	USC/SSI + Rajawali	LOKAL	
<b>2-3</b>		<b>Cross Frame Compl R</b>		<b>1</b>				
	2-3-1	Cross Frame	Pipa Bulat Ø34 x 2.6 x 656 STKM 11 A	1	pcs	ISTW/Sri Rejeki + CIM	LOKAL	
	2-3-2	End Plate [H-002200-3] ▶ (no.13)	Pl.t 4.5 x 44 x 57 SPHC	2	pcs	USC/SSI + Rajawali	LOKAL	
<b>2-3-3</b>		<b>Arm Compl</b>	<b>Assy Rajawali (Las)</b>	<b>2</b>				
	2-3-3-1	Arm [K-110019]	Pl.t 6.0 x 50 x 175 SPHC	2	pcs	USC/SSI + Rajawali	LOKAL	
	2-3-3-2	Plate [K-200003]	Pl.t 4.5 x Ø40 (OD) x Ø12.2 (ID) SPHC	2	pcs	USC/SSI + Rajawali	LOKAL	

No	Rank	Nama Komponen	Spesifikasi Komponen (mm)	Qty / Unit	Suplier + Sub Con	Asal	
						Lokal	Impor/ Alt.Impor
	<b>2-4</b>	<b>Foot Pipe Compl</b>		<b>2</b>			
	2-4-1	FOOT PIPE H-170200-4 ▶ (no.5 & 13)	Pipa Bulat Ø38.1 x 1.6 x 55 STKM 11 A	4 pcs	Rajawali	LOKAL	
	2-4-2	Nut For Caster [K-003004] ▶ (no.13)	Ø38.1 x 21 SS400	4 pcs	Rajawali	LOKAL	
	<b>3</b>	<b>Bottom A Assy</b>		<b>1</b>			
	<b>3-1</b>	<b>Frame pipe + Sunoko compl</b>					
	<b>3-1-1</b>	<b>Frame pipe compl</b>					
	3-1-1-1	Frame (A)	Pipa Kotak 30/20 x 1.6 x 2218 STKR	1 pcs	ISTW/Sri Rejeki + CIM	LOKAL	
	3-1-1-2	Frame (B) ▶ (no.1)	Pipa Kotak 30/20 x 1.6 x 790 STKR	1 pcs	ISTW/Sri Rejeki + CIM	LOKAL	
	3-1-1-3	Pipe / Collar [F-021200-2]	Pipa Bulat Ø12 x 1.6 x 23 STKM 11 A	2 pcs	ISTW/Sri Rejeki + Rajawali	LOKAL	
	<b>3-1-2</b>	<b>Sunoko bottom a compl</b>		<b>1</b>			
	3-1-2-1	Frame L [K-202008L]	Pl.t 1.2 x 58 x 680 SPCC	1 pcs	USC/SSI + Rajawali	LOKAL	
	3-1-2-2	Sunoko Plate A [K-202037]	Pl.t 0.7 x (138) x 778 SPCC	4 pcs	USC/SSI + Hinani	LOKAL	
	3-1-2-3	Sunoko Plate B [K-202038]	Pl.t 0.7 x 115 x 806 SPCC	1 pcs	USC/SSI + Hinani	LOKAL	
	3-1-3	Angle K [E-022401K]/Angle B C-0002-3	Pl.t 1.6 x 34 x 517 SPCC	2 pcs	USC/SSI + Rajawali	LOKAL	
	<b>3-2</b>	<b>Torque Tube Compl</b>		<b>1</b>			
	3-2-1	Torque Tube [H-002311/KC-400043-15]	Pipa Bulat Ø34 x 2.1 x (774) STKM 11 A	1 pcs	ISTW/Sri Rejeki + CIM	LOKAL	
	3-2-2	Arm K-100035 Timotion [Lubang Oval]	Pl.t 4.5 x 50 x 160 SPHC (jarak lubang 14 mm)	2 pcs	USC/SSI + Rajawali	LOKAL	
	3-2-3	Bracket LH [K-202040-1]	Pl.t 3.2 x 80 x 140 SPHC	1 pcs	USC/SSI + Hinani	LOKAL	
	3-2-4	Bracket RH [K-202040-1]	Pl.t 3.2 x 80 x 140 SPHC	1 pcs	USC/SSI + Hinani	LOKAL	
	<b>4</b>	<b>Bottom B Assy</b>		<b>1</b>			
	<b>4-1</b>	<b>Frame pipe + Hinge Compl</b>					
	<b>4-1-1</b>	<b>Frame pipe + Hinge Compl</b>					
	4-1-1-1	Frame (A)	Pipa Kotak 30/20 x 1.6 x 380 STKR	2 pcs	ISTW/Sri Rejeki + CIM	LOKAL	
	4-1-1-2	Frame (B) ▶ (no.2)	Pipa Kotak 30/20 x 1.6 x 788.5 STKR	2 pcs	ISTW/Sri Rejeki + CIM	LOKAL	
	4-1-1-3	Pipe / Collar [F-021200-2]	Pipa Bulat Ø12 x 1.6 x 23 STKM 11 A	2 pcs	ISTW/Sri Rejeki + Rajawali	LOKAL	
	4-1-1-4	Angle E [E-022401E]	Pl.t 1.6 x 34 x 345 SPCC	2 pcs	USC/SSI + Rajawali	LOKAL	
	4-1-2	Hinge Plate [K-200007]	Pl.t 2.3 x 33 x 68 SPCC	4 pcs	USC/SSI + Rajawali	LOKAL	
	<b>4-2</b>	<b>Sunoko bottom b compl</b>		<b>1</b>			
	4-2-1	Sunoko Plate A [K-202037]	Pl.t 0.7 x (138) x 778 SPCC	3 pcs	USC/SSI + Hinani	LOKAL	
	4-2-2	Frame N [K-202008-2]	Pl.t 1.2 x 58 x 278 SPCC	2 pcs	USC/SSI + Rajawali	LOKAL	
	<b>4-3</b>	<b>Torque Tube Compl</b>		<b>1</b>			
	4-4-1	Torque Tube [H-002311/KC-400043-15]	Pipa Bulat Ø34 x 2.1 x (774) STKM 11 A	1 pcs	ISTW/Sri Rejeki + CIM	LOKAL	

No	Rank	Nama Komponen	Spesifikasi Komponen (mm)	Qty / Unit		Suplier + Sub Con	Asal	
							Lokal	Impor/ Alt.Impor
	4-4-2	Arm K-100034 Timotion [lubang Oval]	Pl.t 4.5 x 50 x 160 SPHC (jarak lubang 14 mm)	2	pcs	USC/SSI + Rajawali	LOKAL	
	4-4-3	Bracket LH [K-202040-1]	Pl.t 3.2 x 80 x 140 SPHC	1	pcs	USC/SSI + Hinani	LOKAL	
	4-4-4	Bracket RH [K-202040-1]	Pl.t 3.2 x 80 x 140 SPHC	1	pcs	USC/SSI + Hinani	LOKAL	
<b>5</b>		<b>Bottom C Assy</b>		<b>1</b>				
	<b>5-1</b>	<b>Frame Pipe bottom C</b>						
	5-1-1	Frame (A)	Pipa Kotak 30/20 x 1.6 x 1718 STKR	1	pcs	ISTW/Sri Rejeki + CIM	LOKAL	
	5-1-2	Hinge Plate [K-200007]	Pl.t 2.3 x 33 x 68 SPCC	2	pcs	USC/SSI + Rajawali	LOKAL	
	5-1-3	Angle F [E-022401F]	Pl.t 1.6 x 34 x 360 SPCC	2	pcs	USC/SSI + Rajawali	LOKAL	
	5-1-4	Mat Guard [K-301002]	Ø8 x (464) SS400	1	pcs	Rajawali	LOKAL	
	<b>5-1-5</b>	<b>Bracket roller compl</b>						
	5-1-5-1	Roller Pin [K-005013] ▶(no.8)	Ø6 x 18 x (Lt)20 S20C	2	pcs	Cakra B	LOKAL	
	5-1-5-2	Roller Bracket [K-200006]	Pl.t 2.3 x 33 x 80 SPCC	2	pcs	USC/SSI + Hinani	LOKAL	
	<b>5-2</b>	<b>Sunoko bottom C compl</b>						
	5-2-1	Frame H [K-202008H]	Pl.t 1.2 x 58 x 480 SPCC	1	pcs	USC/SSI + Rajawali	LOKAL	
	5-2-2	Sunoko Plate A [K-202037]	Pl.t 0.7 x (138) x 778 SPCC	3	pcs	USC/SSI + Hinani	LOKAL	
	5-2-3	Sunoko Plate B [K-202038]	Pl.t 0.7 x 115 x 806 SPCC	1	pcs	USC/SSI + Hinani	LOKAL	
<b>6</b>		<b>Bottom Center Compl</b>		<b>1</b>				
	6-1	Sunoko Plate C [K-202019]	Pl.t 0.7 x 134 x 836 SPCC	2	pcs	USC/SSI + Hinani	LOKAL	
	6-2	Frame	Pipa Kotak 30/20 x 1.6 x 220 STKR	2	pcs	ISTW/Sri Rejeki + CIM	LOKAL	
<b>7</b>		<b>Hi-Lo Torque Tube (H) Compl</b>						
	7-1	Torque Tube [H-002021]	Pipa Bulat Ø34 x 2.6 x 388 STKM 11 A	1	pcs	ISTW/Sri Rejeki + CIM	LOKAL	
	7-2	Reinforcement [H-002020-2]	Pl.t 3.2 x 94 x 108 (98) SPHC	1	pcs	USC/SSI + Hinani	LOKAL	
	7-3	Bearing [K-006009]	Ø28.4 x (L)10	2	pcs	Rajawali	LOKAL	
	7-4	Arm [K-100002] Timotion	Pl.t 4.5 x 50 x 184 SPHC (jarak lubang 14 mm)	4	pcs	USC/SSI + Rajawali	LOKAL	
	7-5	Arm [K-100033]	Pl.t 6.0 x 50 x 291 SPHC	2	pcs	USC/SSI + Rajawali	LOKAL	
<b>8</b>		<b>Hi-Lo Torque Tube (F) Compl</b>		<b>1</b>				
	8-1	Torque Tube [H-002021]	Pipa Bulat Ø34 x 2.6 x 388 STKM 11 A	1	pcs	ISTW/Sri Rejeki + CIM	LOKAL	
	8-2	Bearing [K-006009]	Ø28.4 x (L)10	2	pcs	Rajawali	LOKAL	
	8-3	Arm [K-100002]	Pl.t 4.5 x 50 x 190 SPHC (jarak lubang 20 mm)	2	pcs	USC/SSI + Rajawali	LOKAL	
	8-4	Arm [K-100033]	Pl.t 6.0 x 50 x 291 SPHC	2	pcs	USC/SSI + Rajawali	LOKAL	

No	Rank	Nama Komponen	Spesifikasi Komponen (mm)	Qty / Unit		Suplier + Sub Con	Asal		
							Lokal	Impor/ Alt.Impor	
<b>9</b>		<b>Hi-Lo Rod Compl [Finishing Chrome]</b>		<b>1</b>					
9-1		Rod	Pipa Bulat Ø31.8 x 1.6 x 1340 STKM 11 A	1	pcs	ISTW/Sri Rejeki + CIM	LOKAL		
9-2		Spacer [H-002040]	Pl.t 3.2 x 25 x 110 SPHC	2	pcs	USC/SSI + Rajawali	LOKAL		
9-3		Bracket [F-030402]	Pl.t 3.2 x 40 x 168 SPHC	1	pcs	USC/SSI + Hinani	LOKAL		
<b>10</b>		<b>Operating System 3 Compact Crank</b>							
10-1		Compact Crank Assy-A (Head)	S=200 / for back raise - Supply Goods	1	pcs	Local	LOKAL	IMPOR	
10-2		Compact Crank Assy-B (Foot)	S=100 / for foot raise - Supply Goods	1	pcs	Local	LOKAL	IMPOR	
10-3		Compact Crank Assy (Hi/Lo)	S=200 / for hi low - Supply Goods	1	pcs	Local	LOKAL	IMPOR	
10-4		Pin A [K-005020-A] ▶ (no.8)	Ø18 x Ø12 x (L)52 S20C	3	pcs	Cakra B	LOKAL		
10-5		Spacer [K-006508]	Pipa Bulat Ø17.3 x 2.3 x 13 STKM 11 A	2	pcs	ISTW/Sri Rejeki + Rajawali	LOKAL		
10-6		Plain Washer	Ø12	4	pcs	Cahaya.N	LOKAL		
10-7		Snap Pin Dia 12	Ø12	3	pcs	CKA	LOKAL		
10-8		Dantuki Bolt [K-000019] ▶ (no.8)	M10 x P1.5 x Ø16.5 x Ø12.0 x (L)16 x (LT)22 S20C	6	pcs	Cakra B	LOKAL		
10-9		T.Screw (P.Head) M4 x 6	M4 x P0.75 x (L)6	6	pcs	Nitto Alam	LOKAL		
10-10		Plain Washer	Ø4	12	pcs	Nitto Alam	LOKAL		
10-11		Lock Nut M6 ▶ (no.8)	M6 x P1.0	6	pcs	Cakra B	LOKAL		
10-12		Bolt ▶ (no.8)	T/P SCREW P.HEAD M6X16	6	pcs	Sagatek/Garuda M	LOKAL		
10-13		Plain Washer	Ø6	6	pcs	Cahaya.N	LOKAL		
<b>11</b>		<b>Head Board Assy BD-001</b>					LOKAL	IMPOR	
<b>12</b>		<b>Foot Board Assy BD-001</b>					LOKAL	IMPOR	
		<i>Keterangan dapat dilihat di bagian Head &amp; Foot Board</i>						LOKAL	IMPOR
		<b>Side Rail/ Folding Side Rail</b>					LOKAL	IMPOR	
		<i>Keterangan dapat dilihat di bagian Side Rail atau Folding Side Rail</i>						LOKAL	IMPOR
<b>13</b>		<b>Side Bumper Assy</b>		<b>2</b>					
13-1		END CAP KC-800017	(W)24 x (L)30 Colour = Grey [PP]	4	pcs	Santo Plastic	LOKAL		
13-2		BUMPER LIST K-502009	L= 1964, Colour = Grey [PP]	2	pcs	AFMI	LOKAL		
13-3		T/P Screw (P. Head)	M4 x P0.75 x (L)14	4	pcs	Sagatek	LOKAL		
13-4		Plate Bumper List	Pl.t 1.2 x 25 x 100 SPCC	12	pcs	USC/SSI + Rajawali/Hinani	LOKAL		
13-5		Plain Washer	Ø6	12	pcs	Cahaya.N	LOKAL		
13-6		Spring washer	Ø6	12	pcs	Cahaya.N	LOKAL		
13-7		Screw P Head	M6 x 40	12	pcs	Garuda m	LOKAL		

No	Rank	Nama Komponen	Spesifikasi Komponen (mm)	Qty / Unit		Suplier + Sub Con	Asal	
							Lokal	Impor/ Alt.Impor
14		<b>Assy Part</b>						
14-1		Pin B [K-005019-B]	Ø12 x Ø8 x 16 S20C	2	pcs	Cakra B	LOKAL	
14-2		Pin H [K-005019-H]	Ø12 x Ø8 x 41 S20C	4	pcs	Cakra B	LOKAL	
14-3		Dantuki Bolt [K-000001]	M14 x P1.5 x Ø18 x Ø10 x (Lt)31 S20C	4	pcs	Cakra B	LOKAL	
14-4		Dantuki Bolt [K-000002E]	M8 x P1.25 x Ø16.5 x Ø12 x (L)17.5 x (Lt)30 SS400	4	pcs	Cakra B	LOKAL	
14-5		Pin B [K-005020-B]	Ø18 x Ø12 x (L)24 S20C	2	pcs	Cakra B	LOKAL	
14-6		ROLLER K-500001	Colour = White [PE]	2	pcs	Santo Plastic	LOKAL	
14-7		CUSHION RUBBER K-501009	Ø20 x Ø16.5 x (H)10 Colour = Black	2	pcs	P.Rubber	LOKAL	
14-8		CAP 20 X 30 K-503003	(H)13 x (W)20 x (L)30 Colour = Ivory [PE]	8	pcs	Santo Plastic	LOKAL	
14-9		CAP 70 X 30 K-503007	(H)22 x (W)30 x (L)70 Colour = Grey [PE]	4	pcs	Santo Plastic	LOKAL	
14-10		Screw (T.Head)	M5 x P0.8 x (L)15	8	pcs	Sinar terang	LOKAL	
14-11		Washed Nut M.5	M5 x P0.8	8	pcs	Cakra B	LOKAL	
14-12		PLASTIC CAP CM-350 DIA 25.4 ▶ (no.8)	PA/PMMA (Grey)	4	pcs	Imai	LOKAL	
14-13		T/Screw (P. Head)	M5 x P0.8 x (L)8	4	pcs	Sagatek	LOKAL	
14-14		Lock Nut M8 ▶ (no.8)	M8	4	pcs	Cakra B	LOKAL	
14-15		Plain Washer ▶ (no.8)	Ø8	4	pcs	Sagatek	LOKAL	
14-16		Spring washer ▶ (no.7)	Ø5	4	pcs	Sagatek	LOKAL	
14-17		Push Nut M.8	SPN-8 For Axis, M8	6	pcs	Sagatek	LOKAL	
14-18		Snap Pin Dia 12	Ø12	2	pcs	CKA	LOKAL	
14-19		Spring A [K-400004]	Ø23 x Ø4 x (n)98 x (L)396 SWA	2	pcs	Mulia Abadi	LOKAL	
14-20		CUSHION RUBBER K-501003	Ø20 x Ø14 x (H)15 Colour = Black	2	pcs	Kurnia Jaya	LOKAL	
14-21		Screw [E-025011]	Ø6 x (L)14 S20c	2	pcs	Sagatek	LOKAL	
14-22		Lock Nut M6	M6 x P1.0	2	pcs	Cakra B	LOKAL	
14-23		CAP DIA 38 K-503004 for caster	Ø38.1 x (H)20 Colour = Grey [PE]	4	pcs	Santo Plastic	LOKAL	
14-24		Spring washer for Caster	Ø16	4	pcs	Cahaya.N	LOKAL	
14-25		Packing + Material	CBF 2010 x 975 x 170 K200/M150x3/K200 or CB/F W =2350 x D. 1215 (Uk. Besar)	1	pcs	Dwikarya/Trijaya M	LOKAL	
14-26		Bottom Stopper	Ø8 x 1192 SS400	1	pcs	Rajawali	LOKAL	
14-27		Caster With Brake	MFDB-100 grey +T:M16 x (L)20	2	pcs	Sunny	LOKAL	IMPOR
14-28		Caster With No Brake	MFD-100 grey +T:M16 x (L)20	2	pcs	Sunny	LOKAL	IMPOR
				1				
14-31		CHITOSE LABEL (NB)	Sticker	1	pcs	TPO	IMPOR	
14-32		HAND & CAPACITY CAUTION LABEL K-901038	Sticker	1	pcs	TPO	IMPOR	
14-33		LOT MANUFACTURE LABEL FOR CRANK	Sticker	1	pcs	TPO		
14-34		LABEL SNI BESAR UK 25 X 22 MM (BED)	Sticker	1	pcs	TPO		
14-35		SAFETY CAUTION LABEL ▶ (no.12)	Sticker	1	pcs	TPO		
14-36		CAUTION LABEL K-901039	Sticker	1	pcs	TPO		
14-36		STIKER LABEL KEMENKES RI AKD	Sticker	1	pcs	TPO		
14-37		U FOAM ATTY 2 MM X 1220 X 2440	Sticker	1	mtr	TOKO EKSON		
14-38		KLEM PLASTIC PUTIH	>PP<	4	pcs	Others		
14-39		Protection Tape (Caster tape) for caster	SPV-3633, 30 mm light blue	1,6	Mtr	Dunia Baru		
14-40		DOUBLE ADHESIVE TAPE 3M LEBAR 1 CM WARNA	Hi-Bon (L=1 mtr)	1,6	Mtr	Buana		

No	Rank	Nama Komponen	Spesifikasi Komponen (mm)	Qty / Unit	Suplier + Sub Con	Asal	
						Lokal	Impor/ Alt.Impor

							dm2
							Kg
						: - Dinamis	Kg
						- Statis	Kg

No	Rank	Nama Komponen	Spesifikasi Komponen (mm)	Qty / Unit	Suplier + Sub Con	Asal	
						Lokal	Impor/ Alt.Impor

No	Tanggal	No. Tech Info	Keterangan
1	-	-	Frame B (J-0020320) di Bottom A dari pipa STKR 30/20 x t 1.2 x 790 menjadi
2	-	-	Frame (J-0020420) di Bottom B dari pipa STKR 25/12 x t 1.2 x 790 menjadi STKR
3	18/09/06	143/TI-R&D/NB/06	Perubahan spesifikasi Cross Frame (Head), dari pipa STKR 30/20 x t 1.6 x 850
4	27/04/07	166/TI-R&D/NB/07	Perubahan spesifikasi Foot Pipe pada Lower Frame M-3000S Double Lock, dari pipa STKM Ø 38.1 x t 1.6 x 75 menjadi Ø 38.1 x t 1.6 x 55
5	14/08/08	31/TI-R&D/NB/08	Peralihan suplier komponen Spring K-400004A dari Mulia Abadi ke Cikarang
6	17/12/08	38/TI-R&D/NB/08	Peralihan subcon beberapa komponen assy part (Screw,Dantuki Bolt, dll) import
7	-	-	Penggantian label Marquis Label (K-901020) menjadi Chitose Label (CB-901020)
8	05/01/09	-	Penambahan penulisan komponen Screw P Head M6 x 12 pada operating
9	08/01/09	-	Peralihan subcon komponen Side Bumper (K-502009 ) dari import ke AFMI
10	11/01/10	01/TI-R&D/NB/10	Penambahan plastik pada head & foot board untuk BD-001, BD-002, BD-003 dengan spesifikasi (T)0,017 x (W)600 x (L)1150 [plastik standar yamato]
11	09/11/10	55/TI-R&D/10R00	Penambahan part stiker SNI pada semua produk lokal
12	29/12/21	25/TI-R&D/Prod/20	Perubahan & penambahan label pada produk bed : 1. Manufacture label/lot number K-901084 (CB--507) menjadi Lot manufacture label for electric (CB--1214) & for Crank (CB--1213) 2. Penambahan safety caution label (CB--1215) 3. Safety notice (H/F caution label K-901041) (CB -079) menjadi Safety notice
13	12/06/23	12/TI-R&D/NB/23	Perubahan fastener bolt MS-JMP M6x15 menjadi T/P SCREW P.HEAD M6x16

**KETERANGAN UNTUK ALTERNATIF IMPOR :**

No	Kode Bahan	Nama Komponen	Jumlah Potong (Pcs)	Berat Komponen (Kg)	Qty / Unit	Keterangan
10		<b>Operating System 3 Compact Crank (OPTIONAL)</b>				
	RM-NSB-BES-00-0123	BS-44-1 Crank set for back rest			1 SET	Import
	RM-NSB-BES-00-0124	BS-44-2 Crank set for foot rest			1 SET	Import
	RM-NSB-BES-00-0125	BS-44-2 Crank set for height adjustment			1 SET	Import
		<b>Operating System 3 Compact Crank (OPTIONAL)</b>				
	RM-NSB-BES-00-0123	BS-43-1 Crank set for back rest			1 SET	Import
	RM-NSB-BES-00-0124	BS-43-2 Crank set for foot rest			1 SET	Import
	RM-NSB-BES-00-0125	BS-43-3 Crank set for height adjustment			1 SET	Import

11		<b>Head &amp; Foot Board Assy (Lihat DSKB optional accessories)</b>				
	RM-NSB-PLS-00-0421	BS-006A HEAD FOOTBOARD			1 SET	Import
	RM-NSB-CAS-00-0147	BS-028 Caster With Brake	-	-	2 pcs	Import
	RM-NSB-CAS-00-0148	BS-028 Caster Without Brake	-	-	2 pcs	Import
	RM-NSB-CAS-00-0151	BS-028 Caster Central lock	-	-	4 pcs	Import

No	Kode Bahan	Nama Komponen	Jumlah Potong (Pcs)	Berat Komponen (Kg)	Qty / Unit	Keterangan
1	RM-NSB-PLS-00-0418	Side rail kupu-kupu (BS-015A)			1 Set	Import

No	Kode Bahan	Nama Komponen	Jumlah Potong (Pcs)	Berat Komponen (Kg)	Qty / Unit	Keterangan
1	RM-NSB-ALM-00-0032	BS-025 ALLUMINIUM SIDERAIL	Aluminium alloy	-	1 set	Import



# Bossay Medical Appliance Co.,Ltd.



ADD: No.11,3rd East Road, Jiangyi Main Street, Leliu Town, Shunde District, Foshan City, Guangdong Province, China  
TEL: 86 757 27839511 Mob: 86 15626095286 FAX: 86 757 27839512

## PROFORMA INVOICE

### Customer





Name: Febby  
Company: PT CHITOSE INTERNASIONAL TBK  
Address: JL INDUSTRI III NO5 CIMAHI  
Contact: febbyzao@gmail.com overseas@chitose-indonesia.com  
Tel: 16222 6031900

Invoice No.: BS20230907  
Date: Sep07th,2023  
Terms: EXW  
Payment: T/T

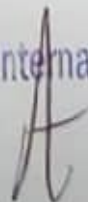
Marks and Numbers	FULL DESCRIPTION OF GOODS	QUANTITY	UNIT PRICE	AMOUNT
BS-006A Head footboard 	2pcs per set	✓	\$40.00	\$120
BS-019 Side rail 	4pcs per set	2 ✓	\$126.00	\$252
BS-43-1 CRANK SET for BACKREST	usd the std crank set	3 ✓	\$9.50	\$29
BS-43-2 CRANK SET for FOOTREST	usd the std crank set	3 ✓	\$9.50	\$29
BS-43-3 CRANK SET for HEIGHT ADJUSTMENT	usd the std crank set	3 ✓	\$9.50	\$29

for  
for  
for  
for  
for

PT. Chitose Internasional Tbk  
Approval 

BS-44-1 CRANK SET for BACKREST	usd the std crank set	3	\$9.50	\$29	OK
BS-44-2 CRANK SET for FOOTREST	usd the std crank set	3	\$9.50	\$29	OK
BS-44-2 CRANK SET for HEIGHT ADJUSTMENT	usd the std crank set	3	\$9.50	\$29	OK
BS-028 CASTOR 	5 Inch with LOCK M16x25mm	4	\$6.50	\$26	OK
BS-028 CASTOR 	5 Inch without LOCK M16x25mm	4	\$6.30	\$25	OK
BS-028 CASTOR 	5 INCH Central lock	8	\$12.50	\$100	OK
BS-015A SIDE RAIL. 	SIDE RAIL without control panel 4pcs per set	4	\$82.00	\$328	OK
BS-025 Aluminum siderail 	Aluminium alloy installation whole in the top tube 2pcs per set	4	\$25.00	\$100	OK
				Deliver cost to container place	\$30
				Bank cost	\$40
				<b>Total</b>	<b>\$1,521</b>

**Total:** SAY USD ONE THOUAND FIVE HUNDRED AND TWENTY ONE ONLY

**Payment Terms:** 100% T/T before shippment

**Delivery Time:** 20DAYS after order confirmed

**Bank Details**

Beneficiary account number: 1037 0109 2406 7  
 Swift code: CITISGSGXXX or CITISGSG  
 Beneficiary country/region: Singapore  
 Beneficiary name: Guangdong Bossay Medical Appliance Co., Ltd.  
 Beneficiary address: 8 Shenton Way, #45-01, AXA Tower, Singapore 068811  
 Beneficiary bank: Citibank N.A Singapore Branch  
 Beneficiary bank address: 08 Marina View #16-01 Asia Square Tower 1 Singapore 018960  
 Bank code: 7214  
 Branch code: 001

PT. Chitose Internasional Tbk

## DAFTAR BAHAN BAKU DAN NAMA SUPPLIER

NO	NAMA BAHAN BAKU	NAMA SUPPLIER	SATUAN	
1	<p>BS-006A Head footboard</p> 	BS 006A HEAD FOOTBOARD	BOSSAY MEDICAL APPLIANCE Co, Ltd.	SET
2	<p>BS-019 Side rail</p> 	BS-019 SIDE RAIL	BOSSAY MEDICAL APPLIANCE Co, Ltd.	SET
3	<p>BS-43-1 CRANK SET for BACKREST</p> 	BS-43-1 CRANK SET FOR BACKREST	BOSSAY MEDICAL APPLIANCE Co, Ltd.	PCS
4	<p>BS-43-2 CRANK SET for FOOTREST</p> 	BS-43-2 CRANK SET FOR FOOTREST	BOSSAY MEDICAL APPLIANCE Co, Ltd.	PCS
5	<p>BS-43-3 CRANK SET for HEIGHT ADJUSTMENT</p> 	BS-43-3 CRANK SET FOR ADJUSTMENT	BOSSAY MEDICAL APPLIANCE Co, Ltd.	PCS
6	<p>BS-44-1 CRANK SET for BACKREST</p> 	BS-44-1 CRANK SET FOR BACKREST	BOSSAY MEDICAL APPLIANCE Co, Ltd.	PCS
7	<p>BS-44-2 CRANK SET for FOOTREST</p> 	BS-44-2 CRANK SET FOR FOOTREST	BOSSAY MEDICAL APPLIANCE Co, Ltd.	PCS
8	<p>BS-44-2 CRANK SET for HEIGHT ADJUSTMENT</p> 	BS-44-2 CRANK SET FOR ADJUSTMENT	BOSSAY MEDICAL APPLIANCE Co, Ltd.	PCS
9	<p>BS-028 CASTOR</p> 	5 INCH WITH LOCK M16 X 25MM	BOSSAY MEDICAL APPLIANCE Co, Ltd.	SET
10	<p>BS-028 CASTOR</p> 	5 INCH WITHOUT LOCK M16 X 25MM	BOSSAY MEDICAL APPLIANCE Co, Ltd.	SET
11	<p>BS-028 CASTOR</p> 	5INCH CENTRAL LOCK	BOSSAY MEDICAL APPLIANCE Co, Ltd.	SET
12	<p>BS-015A SIDE RAIL</p> 	SIDERAIL WOTHOUT CONTROL PANEL 4PCS/SET	BOSSAY MEDICAL APPLIANCE Co, Ltd.	SET

## DAFTAR BAHAN BAKU DAN NAMA SUPPLIER

NO	NAMA BAHAN BAKU	NAMA SUPPLIER	SATUAN
13	<p data-bbox="277 300 448 344">BS-025 Aluminum siderail</p> 	ALLUMUNIUM ALLOY INSTALLATION WHOLE IN THE TOP TUBE 2PCS PER SET	BOSSAY MEDICAL APPLIANCE Co, Ltd.  SET

Self Assessment

**Formulir Rekapitulasi : Nilai TDKN ALAT KESEHATAN DAN ALAT KESEHATAN DIAGNOSTIK IN VITRO**

Penyedia Barang/Jasa	:	PT. Chitose Internasional Tbk
Alamat	:	Jl. Industri III no.5 RT.001 RW.009 Kel. Utama , kec. Cimahi selatan, Cimahi, Ja-Bar
Hasil Produksi	:	Furniture logam, kayu, Plastik & perawatan Kedokteran
Jenis Produk	:	Nursing Bed
Spesifikasi	:	CB 3003
Standar	:	SNI 16-2625-1992 (Tempat Tidur Baja Beroda untuk RS dengan Pengatur Posisi Tidur)
No HS Code	:	o

NO	Uraian	Bobot Penghitungan	KDN	TKDN
			(%)	(%)
I	Aspek Manufaktur	80%	63,33	50,66
II	Aspek Pengembangan	20%	72,50	14,50
<b>TDKN ALAT KESEHATAN DAN ALAT KESEHATAN DIAGNOSTIK IN VITRO</b>				<b>65,16</b>

Capaian Nilai TKDN diatas dinyatakan sendiri (self assessment) oleh PT. Chitose Internasional Tbk

Formulasi Perhitungan :

$\% \text{TKDN Alat kesehatan dan Alat Kesehatan Diagnostik In Vitro} = \% \text{TKDN Aspek Manufaktur} + \% \text{TKDN Aspek Pengembangan}$

Cimahi 25 Oktober 2023

Dinyatakan Oleh,  
PT. Chitose Internasional Tbk



Susanto ST  
Direktur

## Formulir 1.9. : Rekapitulasi Penilaian TKDN Aspek Manufaktur

Penyedia Barang/Jasa	:	PT. Chitose Internasional Tbk
Alamat	:	Jl. Industri III no.5 RT.001 RW.009 Kel. Utama , kec. Cimahi selatan, Cimahi, Ja-Bar
Hasil Produksi	:	Furniture logam, kayu, Plastik & perawatan Kedokteran
Jenis Produk	:	Nuraing Bed
Spesifikasi	:	CB 3003
Standar	:	SNI 16-2625-1992 (Tempat Tidur Baja Beroda untuk RS dengan Pengatur Posisi Tidur)
No HS Code	:	

Uraian		PENILAIAN OLEH PRODUSEN				
		Biaya per 1 (satu) satuan produk				
		Biaya KDN	Biaya KLN	Biaya Total	Persen TKDN	
<b>I</b>	<b>Bahan (material) Langsung</b>	<b>80%</b>				
1.	Bahan Baku untuk Material Langsung	2.158.797,78	1.826.970,57	3.985.768,35	54,16	91,59%
2.	Bahan Baku untuk Biaya Terkait Lainnya	-	-	-	0,00	0,00%
	<b>Sub Biaya Bahan ( Material) Langsung</b>	<b>2.158.797,78</b>	<b>1.826.970,57</b>	<b>3.985.768,35</b>	<b>43,33</b>	<b>91,59%</b>
<b>II</b>	<b>Tenaga kerja Langsung</b>	<b>10%</b>				
1.	Tenaga Kerja Langsung	104.027,88	-	104.027,88	91,82	2,39%
2.	Tenaga Kerja Langsung untuk Biaya Terkait Lainnya	9.268,88	-	9.268,88	8,18	0,21%
	<b>Sub Biaya Tenaga Kerja Langsung</b>	<b>113.296,76</b>	<b>-</b>	<b>113.296,76</b>	<b>10,00</b>	<b>2,60%</b>
<b>III</b>	<b>Biaya Tidak Langsung Pabrik (Factory Overhead)</b>	<b>10%</b>				
1.	Tenaga Kerja Tidak Langsung	5.247,79	-	5.247,79	2,08	0,12%
2.	Mesin yang dimiliki	-	-	-	0,00	0,00%
3.	Mesin yang Sewa	-	-	-	0,00	0,00%
4.	Biaya Tidak Langsung Terkait Lainnya	247.456,90	-	247.456,90	97,92	5,69%
	<b>Sub Biaya Biaya Tidak Langsung Pabrik</b>	<b>252.704,69</b>	<b>-</b>	<b>252.704,69</b>	<b>10,00</b>	
	<b>Biaya Produksi</b>	<b>2.524.799,23</b>	<b>1.826.970,57</b>	<b>4.351.769,80</b>	<b>63,33</b>	

Capaian Nilai TKDN diatas dinyatakan sendiri (self assessment) oleh PT. Chitose Internasional Tbk

## Formulasi Perhitungan

$$\% \text{ TKDN Bahan (material) Langsung} = \frac{\text{Biaya Bahan (material) Langsung} - \text{Biaya Komponen Luar Negeri Bahan (material) Langsung}}{\text{Biaya Bahan (material) Langsung}} \times 80\%$$

$$\% \text{ TKDN Tenaga Kerja Langsung} = \frac{\text{Biaya Tenaga Kerja Langsung} - \text{Biaya Komponen Luar Negeri Tenaga Kerja Langsung}}{\text{Biaya Tenaga Kerja Langsung}} \times 10\%$$

$$\% \text{ TKDN Biaya Tidak Langsung Pabrik} = \frac{\text{Biaya Tidak Langsung Pabrik} - \text{Biaya Komponen Luar Negeri Tidak langsung Pabrik}}{\text{Biaya Tidak Langsaung Pabrik}} \times 10\%$$

$$\% \text{ TKDN Aspek Manufaktur} = \% \text{ TKDN Bahan (material) Langsung} + \% \text{ TKDN Tenaga Kerja Langsung} + \% \text{ TKDN Biaya Tidak Langsung Pabrik}$$

Cimahi 25 Oktober 2023

Dinyatakan Oleh,  
PT. Chitose Internasional Tbk



Susanto ST  
Direktur