



Title :	1. Chair	① Material / Part	Prepared by	Checked by	Approved by
MAPLE RACK LHD	2. Nursing Bed	2. Metoda	 R&D Staff	 Team Leader R&D	 Group Leader R&D
	③ Lainnya ...	3. Mesin			
		4. Lainnya ...			

Subject :	PERUBAHAN KOMPONEN CROSS PIPE 2 MAPLE RACK LHD 1600 X 420 X 1800 MM
------------------	--

Isi**Reason**

- Sebagai pelengkap dokumentasi ISO
- Adanya perubahan panjang cross pipe 2

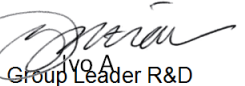
Solution

Berdasarkan perihal diatas maka perlunya tambahan komponen plain washer T.1 x dia 6.5 (RM-NSB-FAS-00-0349) sebanyak 16 pc sebagai support cross pipe 2
Perubahan ini hanya berlaku untuk pengiriman tanggal 07 Juni 2024, untuk kedepannya panjang Cross pipe 2 mengikuti perubahan yang terbaru yaitu panjang 756 mm

Catatan : : - Teknikal Informasi ini berlaku sejak diterbitkannya TI ini

Lampiran : - Gambar teknik terbaru
- Manual guide terbaru



Demikian informasi ini disampaikan,
Atas perhatian dan kerjasamanya kami ucapkan terima kasih

Distribusi ke :

1 President Director	6 Engineerin* Maintenance	10 MIS	15 PCH
2 Administration Director	* Workshop	11 Marketing	①⑥ QC
3 PRD Director	7 Finance	12 Sales	17 MSD
4 Marketing Director	8 General Affair	①③ Production	18 Others ...()
5 Cost Accounting	9 HRD	①④ PPIC	

DAFTAR HADIR RAPAT

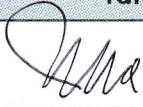
Hari/Tanggal : Kamis, 13 Juni '24
 Waktu : 10.00
 Tempat : R. Meeting R&D
 Agenda Rapat : Perubahan / Tambahan
Komponen Maple Rak LHD

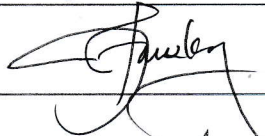
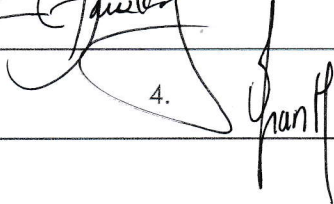
No.	Nama	Bag/Sie	Tanda Tangan
1	Wahyuni	R&D	1. 
2	M. S. R. Y. A.	R&D	2. 
3	Ricky Dwi A	PPIC	3. 
4	Shanty M	QC	4. 
5			5.
6			6.
7			7.
8			8.
9			9.
10			10.
11			11.
12			12.
13			13.
14			14.
15			15.

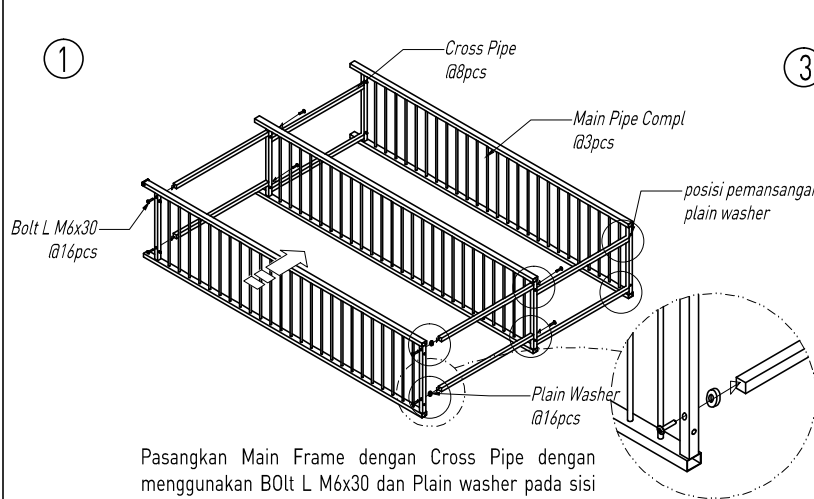

Pasangkan Main Frame dengan Cross Pipe dengan menggunakan Bolt L M6x30 dan Plain washer pada sisi kiri dan kanan Cross Pipe 2

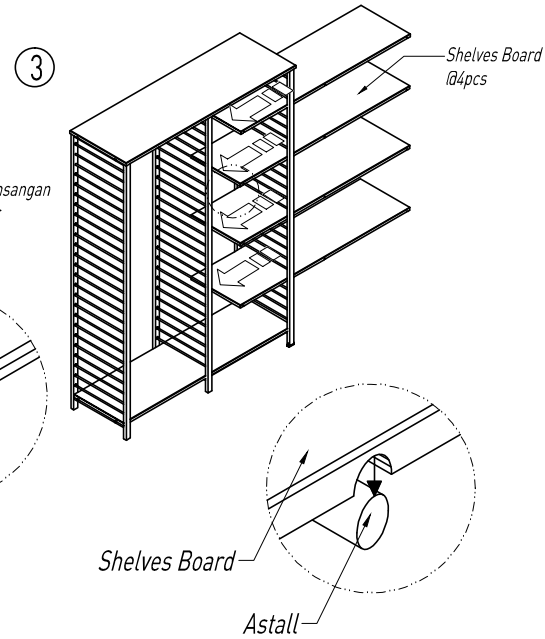

Posisikan Lemari dalam keadaan berdiri, lalu pasang Shelves Board (middle) pada main frame yang telah di instal

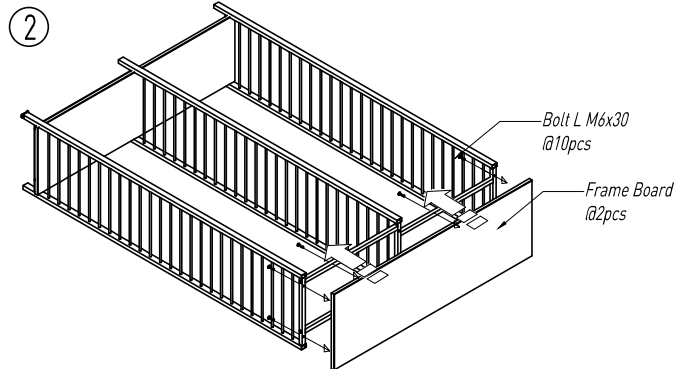

Setelah itu, pasang Frame Board (Top dan Bottom) dengan menggunakan Bolt L M6x30, kencangkan setiap pemasangan bolt dengan Kunci L

Component List

Nama Operator :				
Tanggal :				
NO	COMPONENT	QTY/PACK	IMAGE	CHECK
1	Bolt L M6x30	36 pcs		
2	Kunci L	1 pcs		
3	Plain Washer	16 pcs		

Note : Kebutuhan fastener untuk 1 packing

NO	CODE	COMPONENT	QTY	UNIT	COMPONENT SPESIFICATION
1	-	Cross pipe 2	8	pcs	Pp. Sqr. 20/20 x 1.0 x 756 STKM 11A

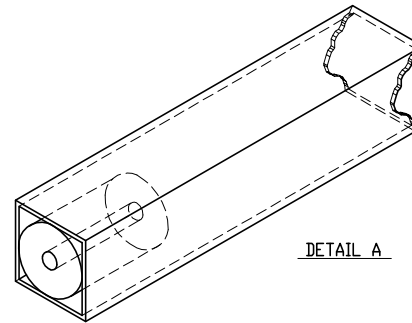
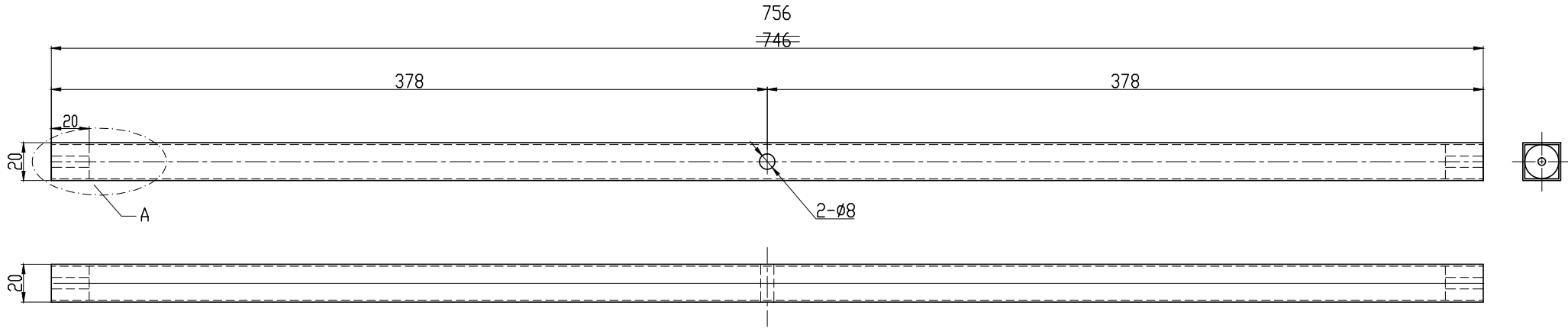

NO	DATE	REMARKS	DRAWN	CHECKED	APPROVED	REVISED BY	Standard Application :	Specification :	Finishing :	Unit :	Paper :	Scale :	Projection :	Drawing Name :	
									PC	mm	A4	1:2		CROSS PIPE 2	
07-06-2024		Perubahan Panjang 746 menjadi 756	Wahyu	-	Ivo A.	-	Drawn : dEvi	Designed/Customer : CIM	Checked : M. Rosyidin	Approved : -	Status : PREPARATION DRAWING PRODUCTION DRAWING	Effective Date : 20-03-2024	Page : 1	PT.Chitose Internasional Tbk Research & Development Dept.	Product Name : MAPLE RACK (L) Custom 1600 x 420 x 1800