

PT. CHITOSE INTERNASIONAL, TBK  
Purchasing Dept.

**LAPORAN SELEKSI VENDOR/SUBKONT**

Formulir : LSS/PCH-CINT/II/2022

NAMA VENDOR/SUB KONT : RODA HAMMERINDO JAYA  
JENIS PRODUK/BAHAN : HEAD BOARD & FOOT BOARD RANAYA

Kriteria Penilaian

PENILAIAN PENETAPAN	B (BAIK)	S (SEDANG)	K (KURANG)
1 MUTU	Sesuai standard CINT Ada sistem Mutu & Garansi	Sesuai Standard CINT Ada sistem Mutu & Garansi	Tidak sesuai Standard CINT Tidak ada sistem mutu
2 PENGIRIMAN	<= 3 Minggu	> 3 Minggu - 1 Bulan	> 1 Bulan
3 HARGA	Paling Murah	Sedang	Paling Mahal
4 PEMBAYARAN	>= 60 Hari	< 60 - 30 Hari	< 30 Hari

Kriteria Penetapan  
1. Diterima = max 1 K (diluar Mutu Barang)  
2. Ditolak = > 1 Kali

HASIL PENILAIAN :

	B	S	K	
1. Kualitas	<input checked="" type="checkbox"/>	<input type="checkbox"/>	<input type="checkbox"/>	(Lampiran hasil Inspeksi/Pengujian produk dari QC)
2. Pengiriman	<input checked="" type="checkbox"/>	<input type="checkbox"/>	<input type="checkbox"/>	(Evaluasi/cek kembali setelah ada order)
3. Harga	<input checked="" type="checkbox"/>	<input type="checkbox"/>	<input type="checkbox"/>	(Perbandingan Harga pembelian)
4. Pembayaran	<input type="checkbox"/>	<input checked="" type="checkbox"/>	<input type="checkbox"/>	

PENETAPAN :  Diterima  Ditolak

CATATAN

DITETAPKAN / DIEVALUASI OLEH

Tanggal : 14 FEBRUARI 2022

KA. BAG PEMBELIAN

NAMA : M. ICHWAN K

TTD :



PERSETUJUAN

Tanggal : 14 FEBRUARI 2022

MANAGER PURCHASING

NAMA : R. MAULUDIN

TTD :

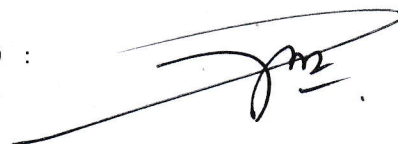

# SURAT PERMINTAAN INSPEKSI // PENGUJIAN PRODUK/KOMPONEN

GINT/OC/F-010/SPI

Kepada : BAGIAN QC  
 Dari :

Bagian DCH TPS-3  
 Cimahi, FEB 2022 Cimahi,.....  
 ( M. Ichwan K. ) ( ..... )

QC  
 Cimahi, 09-02-2022  
 ( Shanty M. )

Nama Komponen : HEAD BOARD FOOT BOARD Nama Supplier/Subkon : RODA HAMMERINDO JAYA  
 Kode Komponen : RM-RNY-PLS-0026 Jumlah Sample : 5 PC  
 Spesifikasi Komponen : PLASTIC BOARD MOLD Waktu penyelesaian Permintaan : .....  
 Inspeksi/Uji

## I. TUJUAN

NO.	TUJUAN	KASIH TANDA (✓)	KETERANGAN	KASIH TANDA (✓)
1.	Ganti Subkon		1. Cost down 2. Kapasitas kurang	
2.	Tambah Supplier/ Subkon		3. Delivery jelek 4. Kualitas jelek	
3.	New Product	✓	5. Perubahan	

### PERBANDINGAN SUPPLIER LAMA VS SUPPLIER BARU

SUPPLIER (LAMA)		SUPPLIER (BARU)	
1.	Nama Supplier	1.	Nama Supplier <u>RODA HAMMERINDO</u>
	Harga Rp.....		Harga Rp.....
2.	Nama Supplier	2.	Nama Supplier
	Harga Rp.....		Harga Rp.....

## II. SYARAT PENGUJIAN

NO.	SYARAT PENGUJIAN	KASIH TANDA (✓)
1.	Kekuatan	
2.	Dimensi Terukur	

## III. CATATAN

\* Hasil inspeksi Visual : OK  
 \* Hasil inspeksi Dimensi Terukur : OK

## IV. KESIMPULAN

HASIL INSPEKSI : OK

Cimahi, Tgl. FEB 2022  
 PEMOHON  
 ( M. Ichwan K. )

Cimahi, Tgl. 09-02-2022  
 BAGIAN QC  
 ( Shanty M. )

TYPE : RANAYA

Nama Komponen : HF Board (FOOT)

Kode Komponen : -

Spec. Komponen : >PP< 920 x 450 x t. 64

**LEMBAR  
INSPEKSI DAN PENGETESAN PENERIMAAN NURSING BED  
(LIPP-NB)**

CINT/QC/F-001/LIPP

Nama Pemasok : **Roda Hammerindo Jaya**

Tgl. Masuk : **8 - 2 - 2022**

No. Surat Jalan : -

Jumlah Diterima : **5 pcs**

Tgl. Surat Jalan : -

Jumlah Sampel : **5 pcs**

Direvisi oleh	Revisi	Disetujui oleh	Tgl. Efektif
Officer of QC	△	QC Asst Mgr	15-11-19
	△		
	△		

**Spesifikasi Yang Diperiksa**

No	Dimensi Terukur	Standar (mm)	Toleransi		Hasil Pengukuran Sampel ke- **)					Range (min - max)	Hasil (OK/NG)
			(+mm)	(-mm)	1	2	3	4	5		
1.	A	920	0,5	0,5	920,2	920,1	920,2	920,2	920,1	920,1 ~ 920,2	OK/NG
2.	B	450	0,5	0,5	450	450	450	450	450,1	450 ~ 450,1	OK/NG
3.	C	415	0,5	0,5	415,2	415,3	415,1	415	415,2	415,0 ~ 415,3	OK/NG
4.	D	35	0,5	0,5	35	35	35	35	35	35	OK/NG
5.	E	64	0,5	0,5	64,5	64,2	64,1	64,2	64,2	64,1 ~ 64,5	OK/NG
6.	F	45	0,5	0,5	45,1	45,1	45,2	45,1	45,2	45,1 ~ 45,2	OK/NG
											OK/NG
											OK/NG
											OK/NG
											OK/NG
											OK/NG
											OK/NG

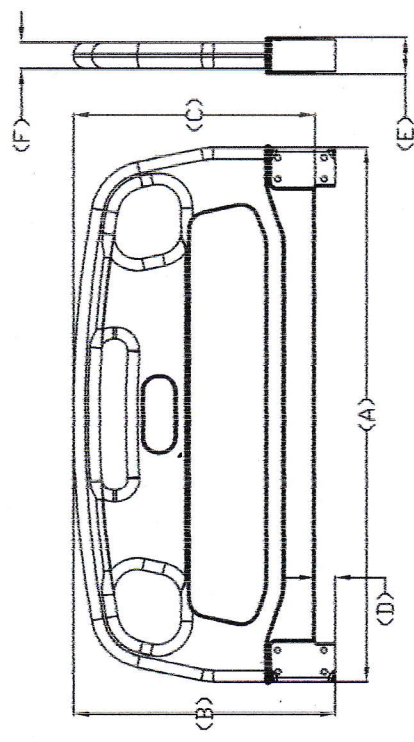

No	Dimensi Tak Terukur	Standar	Alat Ukur	Hasil Pengukuran Sampel ke-***)					Hasil (OK/NG)
				1	2	3	4	5	
1.	Bahan	Tidak cacat / gores	L/R	✓	✓	✓	✓	✓	OK
2.	Warna	Warna sesuai standar	L	✓	✓	✓	✓	✓	OK
3.	Hasil Proses	Tak tajam, tdk ada kelebihan sisa plastik	L	✓	✓	✓	✓	✓	OK

**CATATAN HASIL INSPEKSI**

**KETERANGAN**  
 JS : Jangka Sorong  
 RM : Roll Meter  
 MT : Mistar  
 BP : Bevel Protractor  
 L : Dilihat  
 R : Diaba  
 \* : Lingkari yg dituliskan  
 \*\* : Isi dengan angka  
 \*\*\* : Isi dgn tanda ( ✓ ) bila OK, dan tanda ( X ) bila NG

Cimahi, Tgl. **9 - 12 - 2022**  
 Diperiksa oleh  
  
 ( Shanty M )

Cimahi, Tgl. **9 - 12 - 2022**  
 Diperiksa oleh  
  
 ( Shanty M )

Cimahi, Tgl. **9 - 12 - 2022**  
 Diperiksa oleh  
  
 ( Shanty M )

**KEPUTUSAN\*)**  
 OK | NG

TYPE : RANAYA

Nama Komponen : HF Board (HEAD)

Kode Komponen : -

Spec. Komponen : >PP<, 920 x 530 x t. 64

**LEMBAR  
INSPEKSI DAN PENGETESAN PENERIMAAN NURSING BED  
(LIPP-NB)**

CINT/QC/F-001/LIPP

Nama Pemasok : *Roda Hammerindo Jaya*

Tgl. Masuk : 8-2-2022

No. Surat Jalan : -

Jumlah Diterima : 5 pcs

Tgl. Surat Jalan : -

Jumlah Sampel : 5 pcs

Direvisi oleh	Revisi	Dijetui oleh	Tgl. Efektif
Officer of QC	△	QC Asst Mgr	15-11-19
	△		
	△		

**Spesifikasi Yang Diperiksa**

No	Dimensi Terukur	Standar (mm)	Toleransi		Hasil Pengukuran Sampel ke- **)					Range (min - max)	Hasil (OK/NG)	
			(+mm)	(-mm)	1	2	3	4	5			
1.	A	920	0.5	0.5	RMJS	920,2	920,1	920,2	920,1	920,1	920,1 ~ 920,2	OK/NG
2.	B	530	0.5	0.5	RMJS	530,2	530,1	530,2	530,3	530,1	530,1 ~ 530,2	OK/NG
3.	C	415	0.5	0.5	RMJS	415,2	415,1	415,2	415,1	415,2	415,1 ~ 415,2	OK/NG
4.	D	115	0.5	0.5	RMJS	115	115	115	115	115	115	OK/NG
5.	E	64	0.5	0.5	RMJS	64,2	64,1	64,2	64,1	64,1	64,1 ~ 64,2	OK/NG
6.	F	45	0.5	0.5	RMJS	45,1	45,2	45,2	45,1	45,1	45,1 ~ 45,2	OK/NG
												OK/NG
												OK/NG
												OK/NG
												OK/NG
												OK/NG

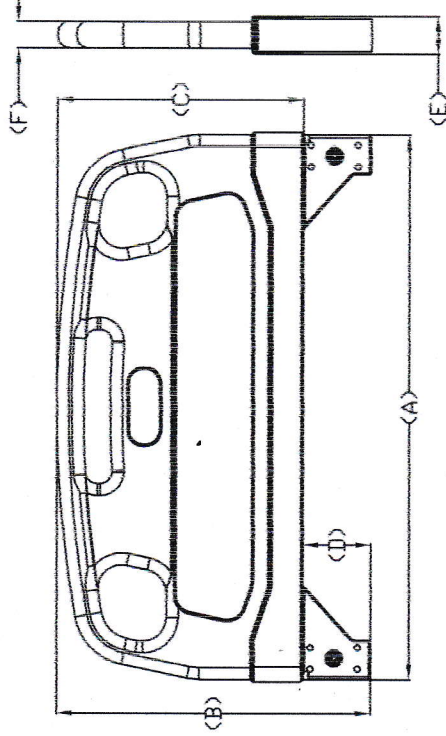

No	Dimensi Tak Terukur	Standar	Alat Ukur	Hasil Pengukuran Sampel ke- ***)					Hasil (OK/NG)
				1	2	3	4	5	
1.	Bahan	Tidak cacat / gores	L/R	✓	✓	✓	✓	✓	OK
2.	Warna	Warna sesuai standar	L	✓	✓	✓	✓	✓	OK
3.	Hasil Proses	Tdk tajam, tdk ada kelebihan sisa plastik	L	✓	✓	✓	✓	✓	OK

**CATATAN HASIL INSPEKSI**

KETERANGAN

JS : Jangka Sorong     L : Dilihat     \* : Lingkaran yg diputar  
 RM : Rol Meter        R : Diraba        \*\* : ke dengan angka  
 MT : Mistar                               \*\*\* : ke dgn tanda (✓) bila OK, dan tanda (X) bila NG  
 BP : Bevel Protractor   

Cimahi, Tgl. 9-2-2022  
Dijetui oleh,  
*A. Yuni*

Cimahi, Tgl. 9-2-2022  
Diperiksa oleh,  
*shanty*

Cimahi, Tgl. 9-2-2022  
Dijetui oleh,  
*Yuban S.*

**KEPUTUSAN\*)**

OK | ~~NG~~



NO	CODE	COMPONENT	QTY	UNIT	COMPONENT SPECIFICATION
1	-	HEAD BOARD PLASTIC	.	pcs	>PR<. 920 x 530 x t. 64

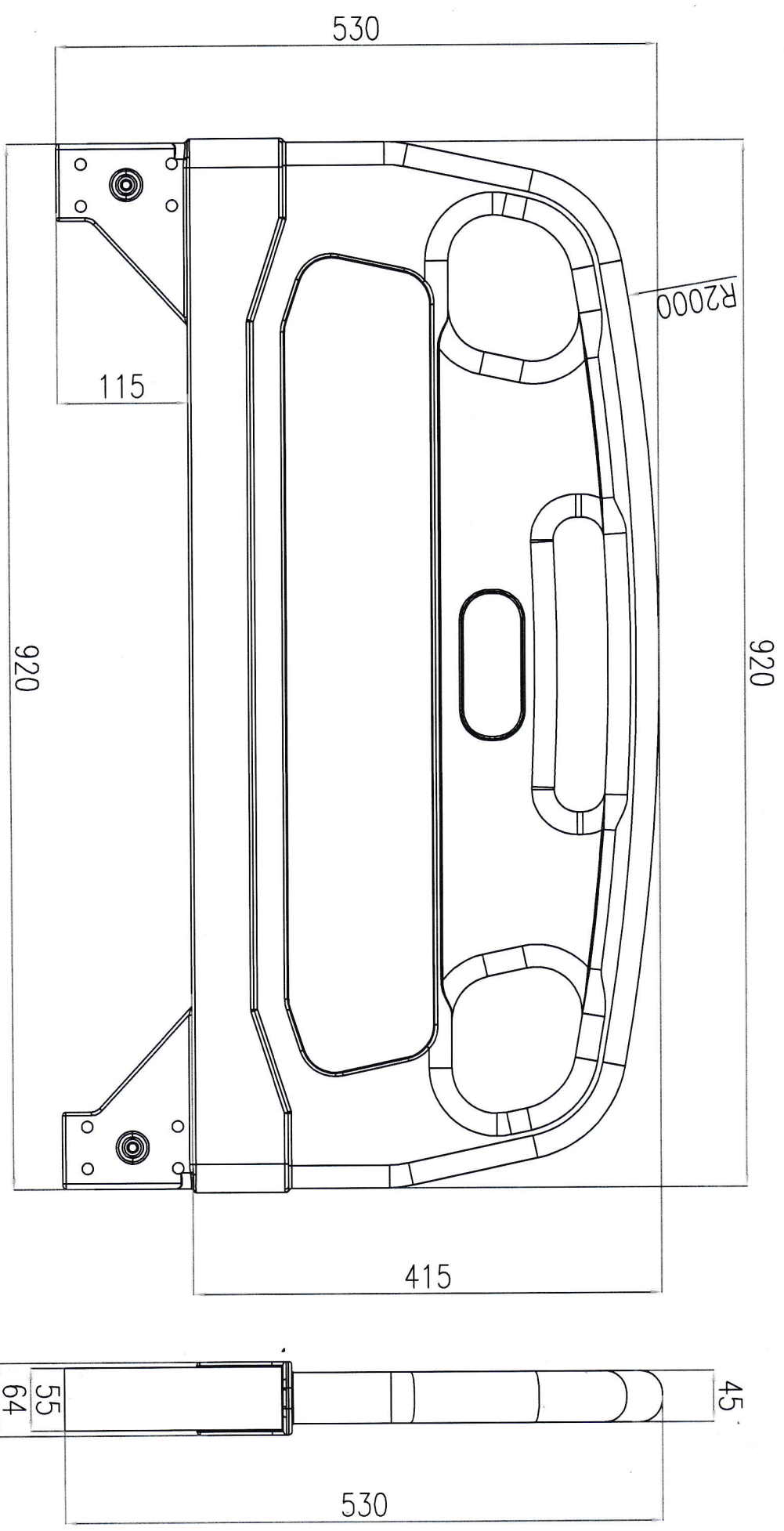

NO	DATE	REVISIONS	DRAWN	CHECKED	APPROVED	DESIGNED BY
Δ						
Δ						
Δ						

Standard Application :		Specification :		Finishing :		Unit :		Figure :		Scale :		Projection :		Drawing Name :			
Drawn : [I/M/N]		Designed/Customer : CIM		Checked : KATMO L		Approved : M. Rosyidi		Scale : PREPARATION DRAWING		Date Date : XX-XX-XXXX		Page : -		PT. Chitose Internasional Tbk. Research & Development Dept.		HEAD BOARD PLASTIC	
				PRODUCTION DRAWING												ODISSEA RN DS 03R ELECTRIC	

Registration No. 0762004953R0 40/00



# QUALITY MANAGEMENT SYSTEM CERTIFICATE

The certificate information is available on the CNCA of the official website ([www.cnca.gov.cn](http://www.cnca.gov.cn))

This is to certify that the quality management system of

**Zhongshan Aolike Medical Equipment Technology Co., Ltd.**

Uniform Code of Social Credit: 91440000709669467

Reg. Add: No. 51, West Donghai Road, Dongfeng Town, Zhongshan City

Pro. Add: No. 51, West Donghai Road, Dongfeng Town, Zhongshan City, Guangdong, China

Which is in conformity with

**GB/T19001-2016/ISO9001:2015**

This certificate covers the following scope of

Within the scope of license general hospital bed, hand-cranked hospital bed (including hand beds, hand-cranked beds, hand-cranked beds, hand-held three-fold beds), electric beds, medical electric beds, manual wheelchairs, electric wheelchairs, crutches, walker design, production and sales; the second category of medical equipment sales

This certificate will not remain valid unless and until the certified customers accepts at least once surveillance audit annually within the validity period of the certificate and the surveillance audit conforming mark is affixed to the designated place on the certificate. Please login into [www.zrxkj.com](http://www.zrxkj.com) for this certificate's validity status

Issue Date: 07. 03. 2020

Expiration Date: 07. 02. 2021

Beijing Zhongsheng Certification Co., Ltd.

No. 51, West Donghai Road, Dongfeng Town, Zhongshan City, Guangdong, China

Issued by:

*X.R. Zhang*

