



NURSING BED

Healthy Therapy Product



NURSING BED CB 3012 Plus

Nursing Bed CB 3012 Series is a type of bed that functions to support special needs for people who are sick, disabled, and people with special needs (breastfeeding and the elderly). This bed is built with the characteristics of iron pipe and plate construction including a lying surface, bottom surface construction and accessories. For more ergonomic care, the CB 3012 Series Nursing Bed works manually using the Crank system, to adjust the height of the bed and Head Rest position

Standard Function

- Operating System : 2 Crank operation for High-Low and Head Rest positions
- Position : - High – low: Manual operation with Crank
- Head rest: Manual operation with Crank with tilting from 0 to 80 degrees
- Primary : - Simple design, no sharp corners (smooth surface)
- Easy operating mechanism, with Crank System
- Sturdy and anti-rust
- Wheels that are easy to move and position, with lock - unlock system
- Lock System : Double Lock System on the Wheels
- Accessories : IV Pole (2 Type Option) and Side Rail / Folding Side rail
Bed Side Cabinet, Over Bed Table, and Foot Step
Airmate Cpro Mattress / Urethane



NURSING BED

Healthy Therapy Product

Product Dimension

Dimension : L : Total 2230 mm (include H/F Board)
 1956 mm (Bottom assy Lenght)
 W : Total 1030 mm
 915 mm (Bottom assy Widht)
 D : 760 ~ 1005 mm (from floor to Head Board)
 : 327 ~ 667 mm (from floor to Bottom Assy)

Product Weight

Weight : ± 90KG
 Load Capacity : ± 400KG (Static) & ±170KG (Dynamic)
 Packing Dimension : 2050 mm (L) x 1070 mm (W) x 190 mm (D)

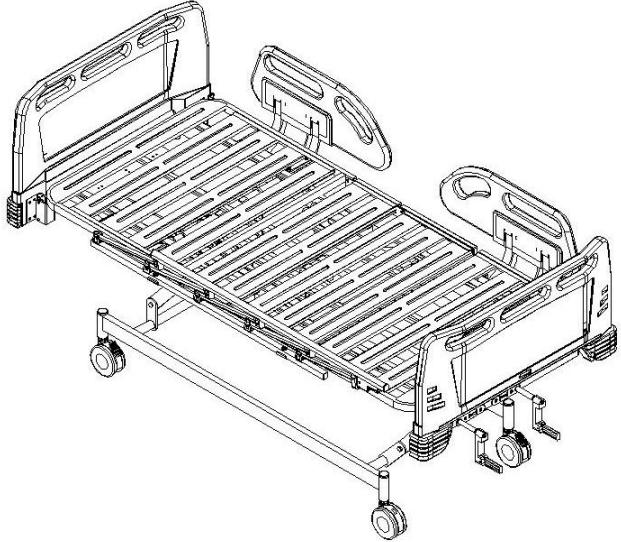
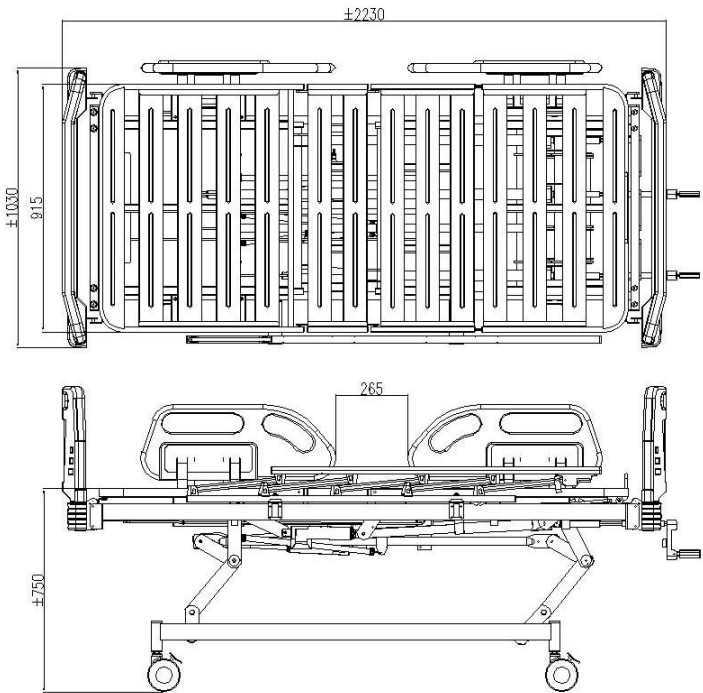

Material Product Specification

Frame : STKR & STKM 11A Pipe 1.6~1.8mm mainly for Main frame and Bottom frame
 SPCC & SPHC Plate for Support and support component
 Finishing : Powder Coating White Colour
 Castor : EUDC-125+T:28X96 Swivel with central, total lock,directional lock
 Head & Foot Board : HDPE (High-density polyethylene)
 Corner Bumper : PP (Polypropylene)
 Bumper List : ABS (Acrylonitrile butadiene styrene)
 Packing Case : 1 box for 1 Nursing Bed
 Cardboard Box CB/F 2050 x 1070 x 190 K200/M150x3/K200