

CB-3003 PLUS

GTKP

Gambar Teknik
Komponen Produk

3012 PLUS	
3003 PLUS	✓
3300 PLUS	

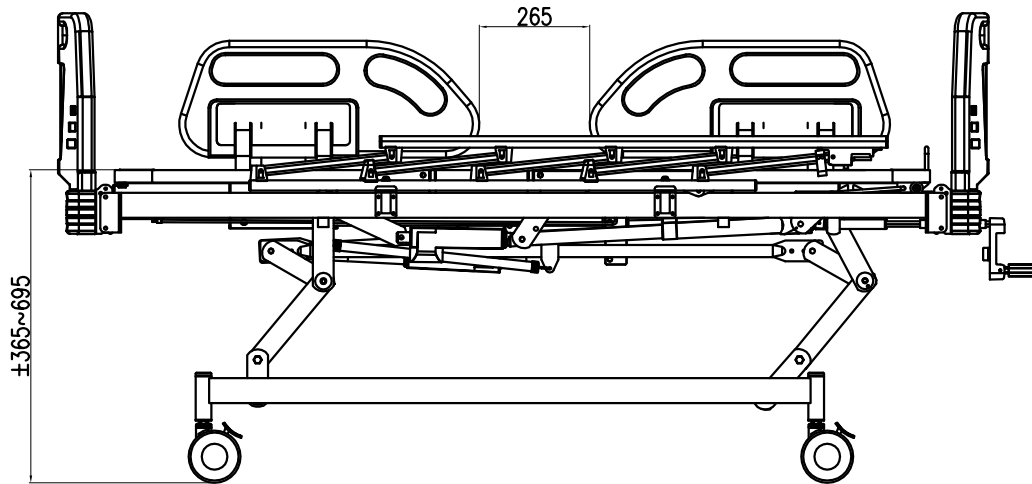
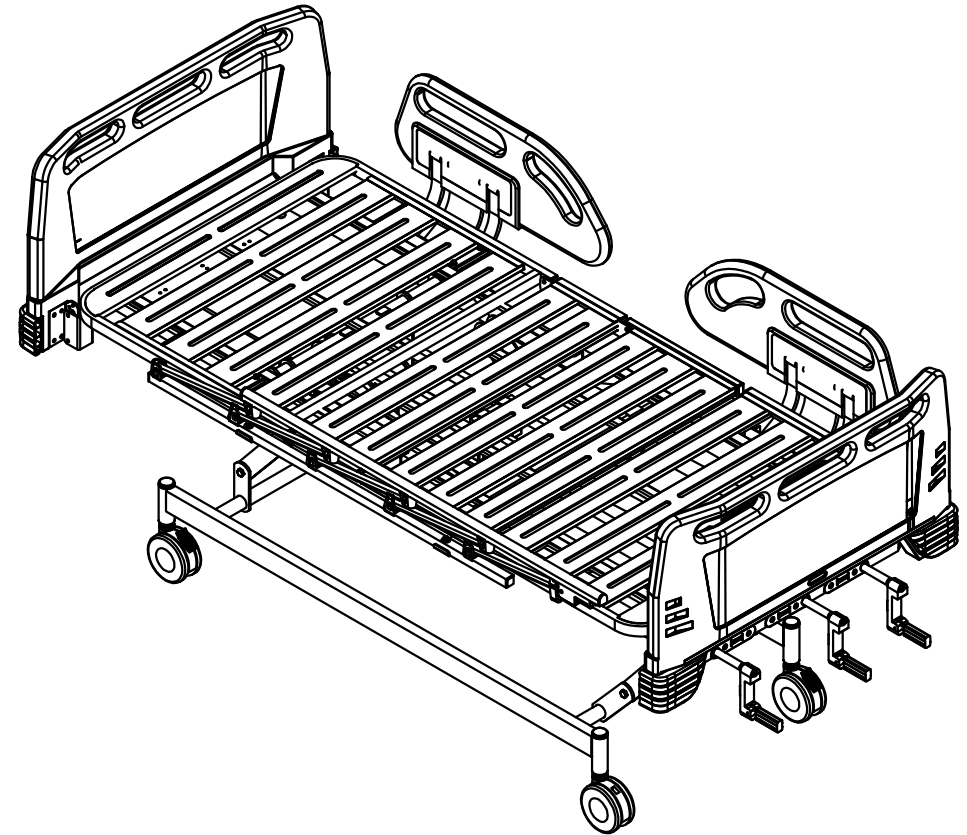
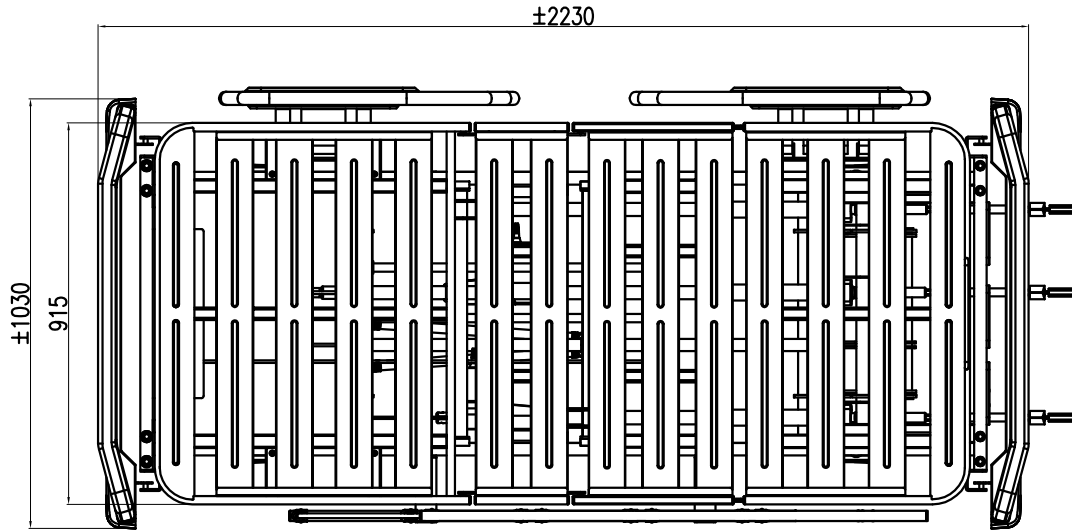

△						
△						
△	-	-	-	-	-	-
NO	DATE	REMARKS	DRAWN	CHECKED	APPROVED	REVISED BY

Standard Application :				Specification :		Finishing :		Unit :		Paper :		Scale :		Projection :		Drawing Name :	
				-		-		mm		A4		1:X				DIMENSION	
Drawn :		Designed/Customer :		Checked :		Approved :		Status :		Effective Date : XX-XX-XXXX		Page :		PT.Chitose Internasional Tbk. Research & Development Dept.			
[I/A/N]		CIM		M.Rosyidin		M.Rosyidin		<input checked="" type="checkbox"/> PREPARATION DRAWING <input type="checkbox"/> PRODUCTION DRAWING		Plote Date : XX-XX-XXXX		00					
Product Name :																CB-3003 PLUS	

NO	CODE	COMPONENT	QTY	UNIT	COMPONENT SPECIFICATION
1	.	Side Frame	2	PCS	Pp.60/30 x t 1.8 x 1998, STRM 11A
2	.	Cross Frame A (Head) Compl.	1	PCS	Pp. 60/30 x t 1.8 x 750, STRM 11A
3	.	Cross Frame B (Foot) Compl.	1	PCS	PL t 1.6 x 139 x 750, SPCC
4	.	Cross Member A Compl.	1	Unit	-
5	.	Cross Frame Center	1	PCS	Pp. 50/30 x t 1.6 x 620, STRM 11A
6	.	Cross Member B Compl.	1	Unit	-
7	K-202048	Bracket Center	2	Pcs	PL 3.2 x 100 x 220, SPCC
8	.	Stopper Pipe	4	Pcs	Pp. ϕ 25.4 x t 1.2 x 22-53, STRM 11A
9	K-212005	Roller Support	2	Pcs	-
10	K-202048	Stopper Bracket	4	Pcs	-
11	K-300002	Holder	8	Pcs	-
12	K-212015	Hook Bracket	4	Pcs	-
13	.	Rivet Nut	18	Pcs	M6
14	.	Bracket Frame Compl.	1	Unit	-
15	K-202061	Angle K	2	Pcs	PL t 4.5 x 35 x 98, SPCC-S0

JARAK CRANK BRACKET K-100032 DI PERLEBAR (AWAL 63 MENJADI 72) SUPAYA COVER PLASTIC BOSSAY MASUK

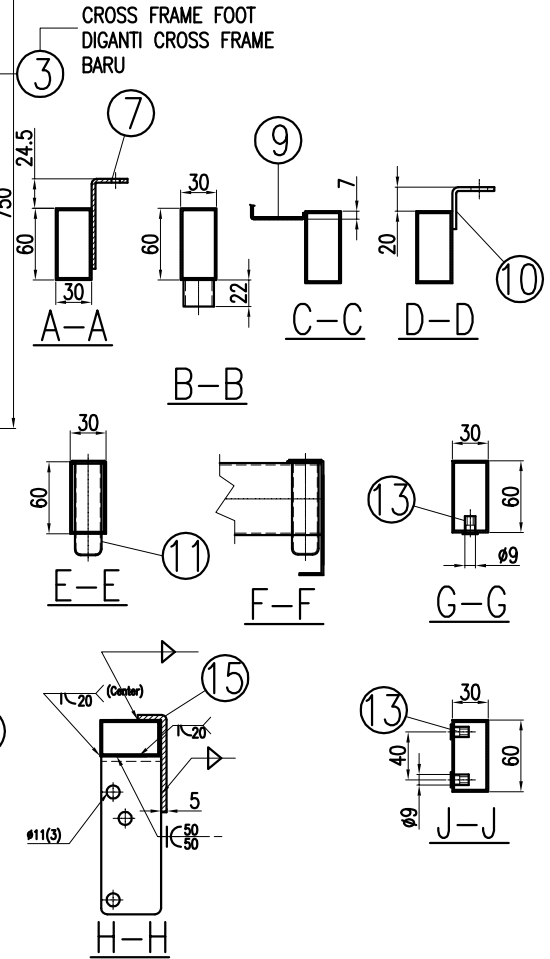
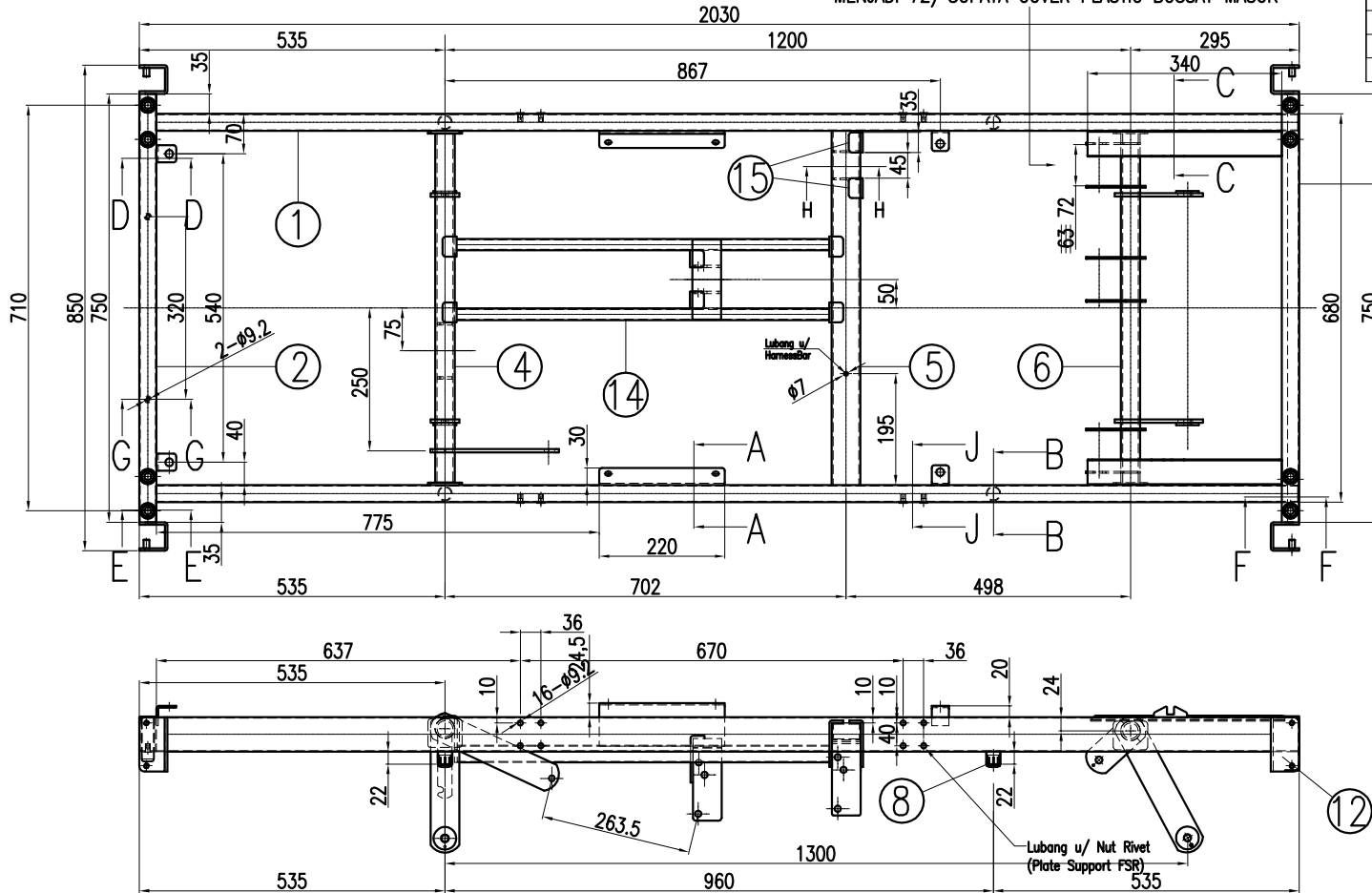

Standard Application :				Specification :		MODEL :		Unit :	Paper :	Scale :	Projection :	Drawing Name :
								mm	A4	1:X		Main Frame Compl.
Drawn :	Designed/Customer :	Checked :	Approved :	Status :	Effective Date :	Page :	PT.Chitose Internasional Tbk.		Product Name :			
[I/A/N]	CM	M.Rosyidin	M.Rosyidin	PREPARATION DRAWING PRODUCTION DRAWING	31-08-2023	1	Research & Development Dept.		CB 3012/3003/3300 PLUS			

NO	CODE	COMPONENT	QTY	UNIT	COMPONENT SPECIFICATION
1	.	Harness Bar	1	PCS	Asstall Ø6 x 1180

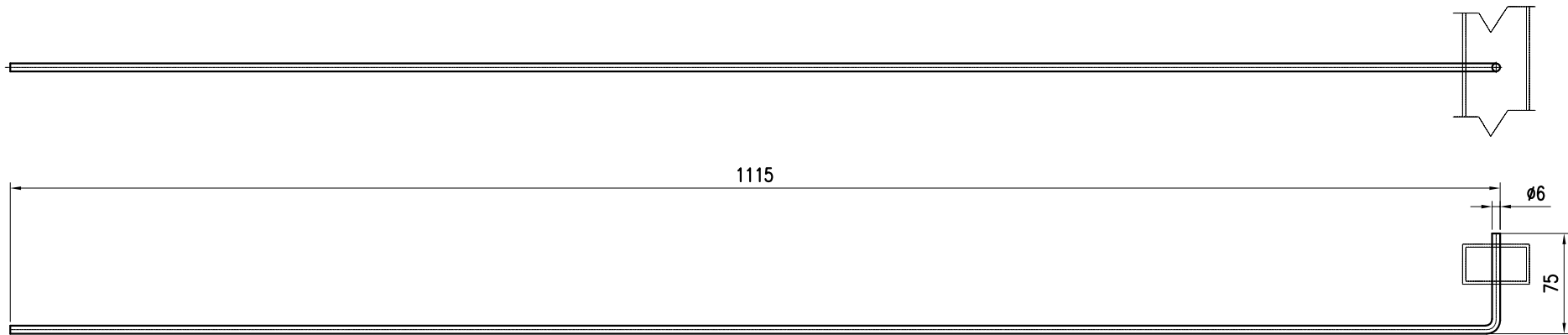

Standard Application :				Specification :		MODEL :	Unit :	Paper :	Scale :	Projection :	Drawing Name :
-				-		INDOMEDIK OPTIMUS 3E	mm	A4	1:X		Harness Bar
Drawn :	Designed/Customer :	Checked :	Approved :	Status :	Effective Date :	Page :	PT.Chitose Internasional Tbk.		Product Name :		
[I/A/N]	CIM	M.Rosyidin	M.Rosyidin	<input type="checkbox"/> PREPARATION DRAWING <input checked="" type="checkbox"/> PRODUCTION DRAWING	06-02-2023	8	Research & Development Dept.		CB-3012/3003/3300 PLUS		
					Plote Date :	XX-XX-XXXX					

NO	CODE	COMPONENT	QTY	UNIT	COMPONENT SPECIFICATION
1	-	Frame A	1	pcs	Pp. 30/20 x t 1.6 x (2308) STKM11A
2	-	Frame B	1	pcs	Pp. 30/20 x t 1.6 x 875 STKM 11A
3	F-021200	Pipe / Collar	2	pcs	Ø12 x t 1.6 x 23 STKM 11A
4	H-002310	Torque Tube Compl.(Modif)	1	Unit	-
5	E-022401	Angle K	2	pcs	Pl. t 1.6 x 34 x 517 SPCC
6	K-202008	Frame	L1	pcs	Pl. t 1.2 x 58 x 680 SPCC
7	K-202037	Sunoko Plate A	A4	pcs	Pl. t 0.7 x 134 x 861 SPCC
8	K-202038	Sunoko Plate B	1	pcs	Pl. t 0.7 x 110 x 890 SPCC
9	.	Plate Frame 32/12 A	2	pcs	Pl. t 2.0 x (48) x 680, SPHC
10	.	Plate Frame 32/12 B	4	pcs	Pl. t 2.0 x (48) x 115, SPHC
11	.	Plate Support	2	pcs	Pl. t 9 x 25 x 115, SPHC
12	.	Plange Nut	8	pcs	M6

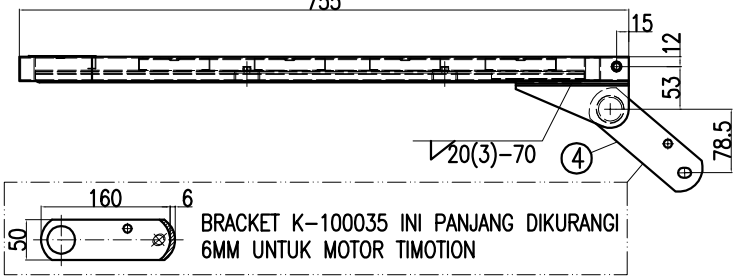
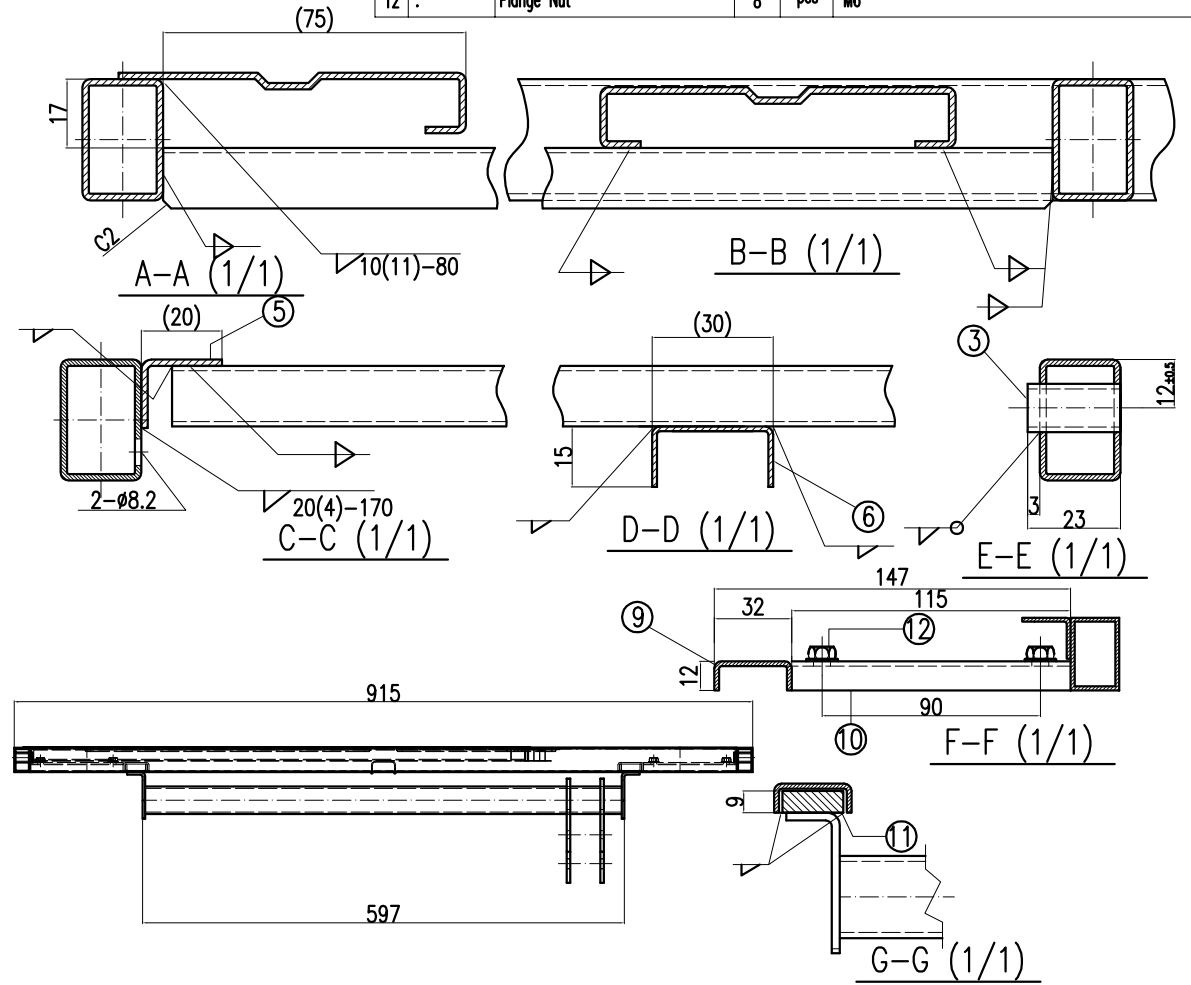
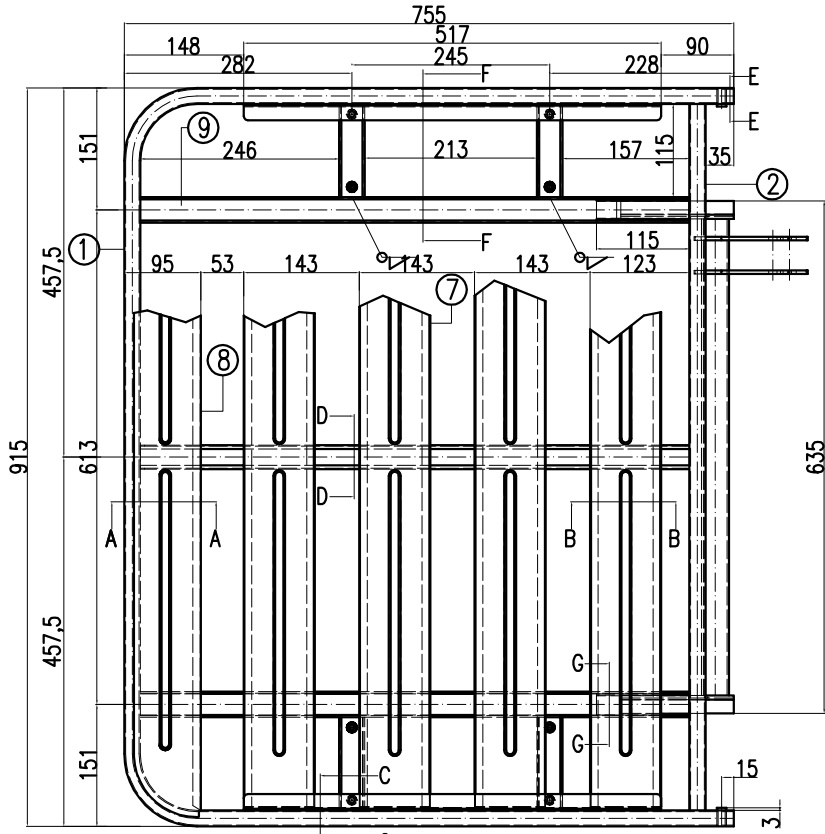

NO	DATE	REMARKS	DRAWN	CHECKED	APPROVED	REVISED BY

Standard Application :	Specification :	Finishing :	Unit :	Paper :	Scale :	Projection :	Drawing Name :
-	-	-	mm	A4	1:X		BOTTOM A COMPL.
Drawn :	Designed/Customer :	Checked :	Approved :	Status :	Effective Date :	Page :	Product Name :
[I/A/N]	CIM	M.Rosyidin	M.Rosyidin	PREPARATION DRAWING PRODUCTION DRAWING	11-02-2023 XX-XX-XXXX	09	PT.Chitose Internasional Tbk. Research & Development Dept. CB-3012/3003/3300 PLUS

NO	CODE	COMPONENT	QTY	UNIT	COMPONENT SPESIFICATION
1	-	Torque Tube	1	pcs	Pp. $\varnothing 34$ x t $\neq 2.0$ x 590 STKM 11A
2	K-100035	Arm K	2	pcs	Pl. t 4.5 x 50 x 166 SPHC
3	K-202040-1	Bracket L/R	2	pcs	Pl. t 3.2 x 80 x 140 SPHC

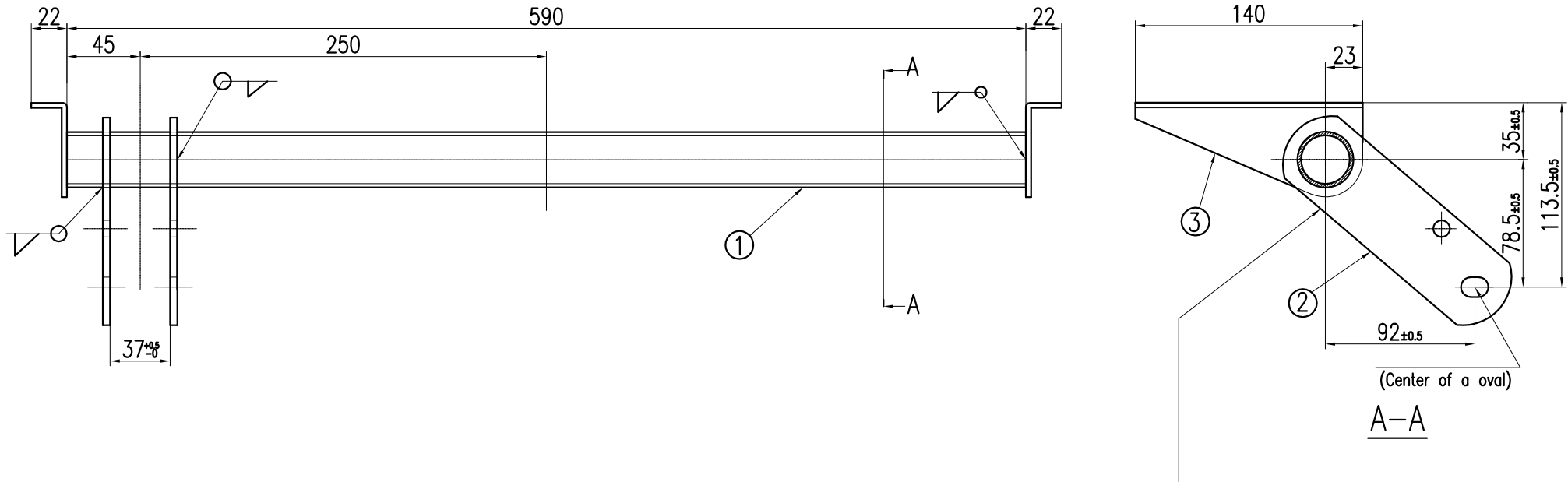

<Notes>

1. Bury and spatter and projection and out of welding to the backside shall be 0.5mm or less.
2. The details by a meeting. Submit a sample for approval if necessary.

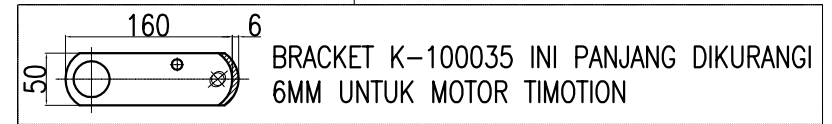

NO	DATE	REMARKS	DRAWN	CHECKED	APPROVED	REVISED BY
-	-	-	-	-	-	-

Standard Application :				Specification :		MODEL :		Unit :	Paper :	Scale :	Projection :	Drawing Name :
								mm	A4	1:X		TORQUE TUBE COMPL. (BOTTOM A)
Drawn :	Designed/Customer :	Checked :	Approved :	Status :	Effective Date :	Page :	PT.Chitose Internasional Tbk.		Product Name :			
[I/A/N]	CIM	M.Rosyidin	M.Rosyidin	PREPARATION DRAWING PRODUCTION DRAWING	11-02-2023	10	Research & Development Dept.		CB-3012/3003/3300 PLUS			

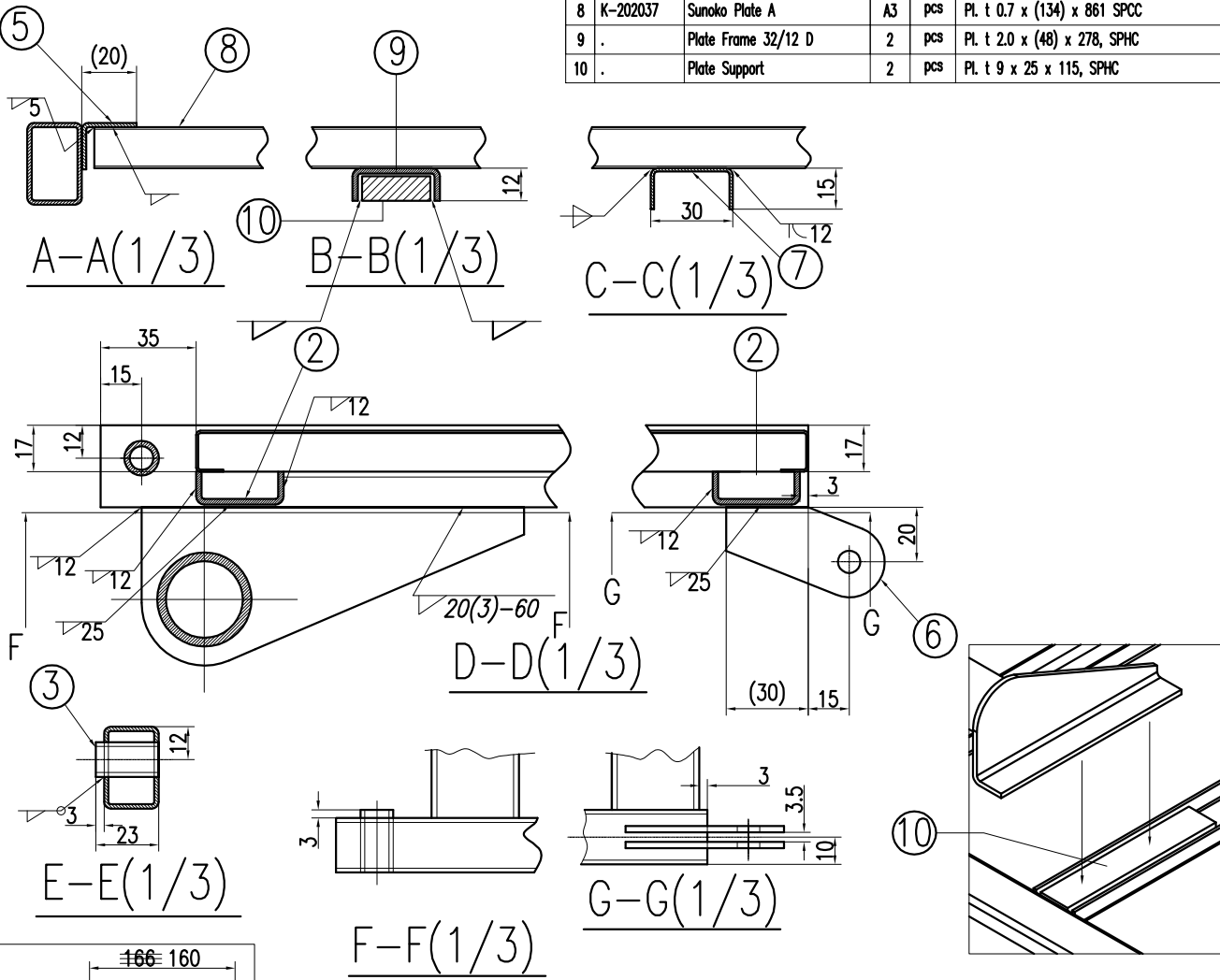
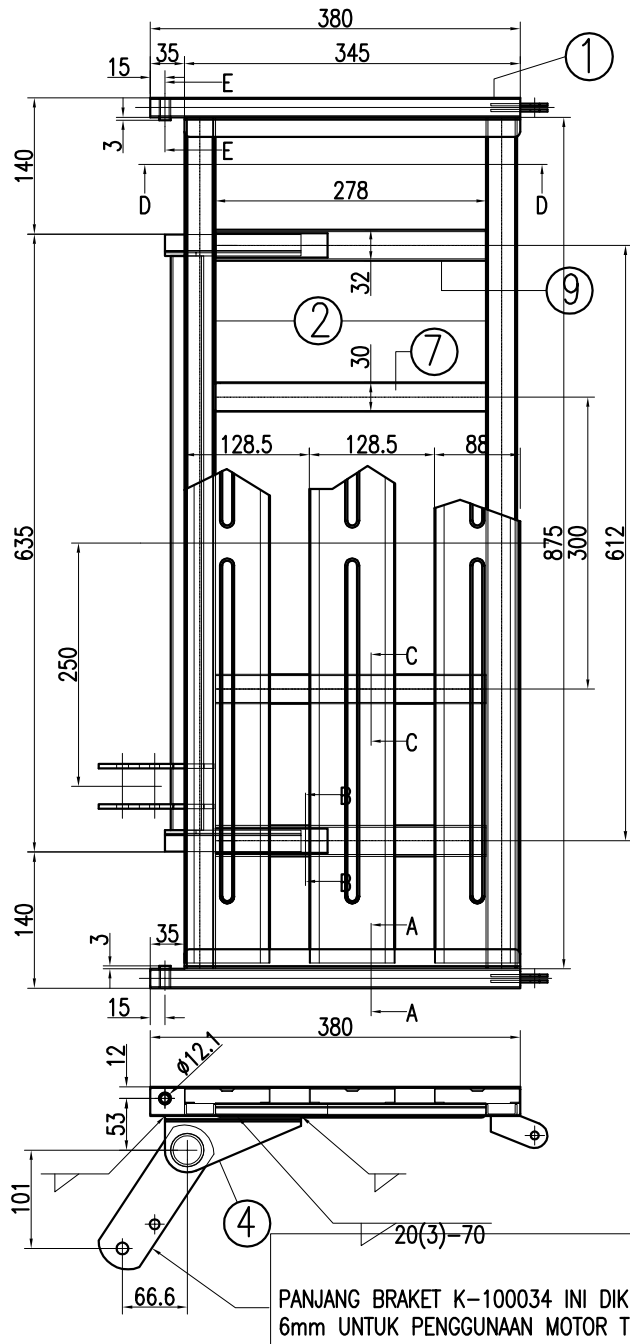

PANJANG BRACKET K-100034 INI DIKURANGIN 6mm UNTUK PENGGUNAAN MOTOR TIMOTION

NO	CODE	COMPONENT	QTY	UNIT	COMPONENT SPESIFICATION
1	J-0020410	Frame A	2	pcs	Pp. 30/20 x t 1.6 x 380 STRK
2	.	Plate Frame 32/12 C	2	pcs	Pl. t 2.0 x (48) x 875, SPHC
3	F-021200-2	Pipe / Collar	2	pcs	Ø12 x t 1.6 x 23 STKM 11A
4	H-002410	Torque Tube Compl.(modif)	1	Unit	-
5	E-022401	Angle E	E2	pcs	Pl. t 1.6 x 34 x 345 SPCC
6	K-200007	Hinge Plate	4	pcs	Pl. t 2.3 x 33 x 68 SPCC
7	K-202008	Frame N	N4	pcs	Pl. t 1.2 x 58 x 278 SPCC
8	K-202037	Sunoko Plate A	A3	pcs	Pl. t 0.7 x (134) x 861 SPCC
9	.	Plate Frame 32/12 D	2	pcs	Pl. t 2.0 x (48) x 278, SPHC
10	.	Plate Support	2	pcs	Pl. t 9 x 25 x 115, SPHC

NO	DATE	REMARKS	DRAWN	CHECKED	APPROVED	REVISED BY

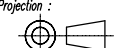
Standard Application :				Specification :		MODEL :		Unit :		Paper :		Scale :		Projection :		Drawing Name :	
-				-		INDOMEDIK OPTIMUS 3E		mm		A4		1:X				BOTTOM B COMPL.	
Drawn :		Designed/Customer :		Checked :		Approved :		Status :		Effective Date :		Page :		Product Name :			
[I/A/N]		CIM		M.Rosyidin		M.Rosyidin		<input checked="" type="checkbox"/> PREPARATION DRAWING <input type="checkbox"/> PRODUCTION DRAWING		11-02-2023		11		PT.Chitose Internasional Tbk. Research & Development Dept.			
														CB-3012/3003/3300 PLUS			

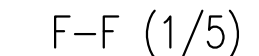
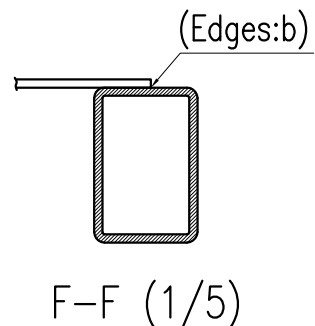
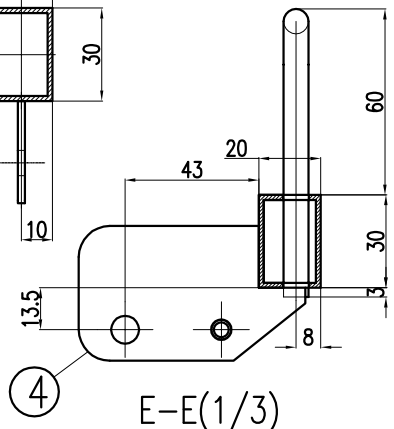
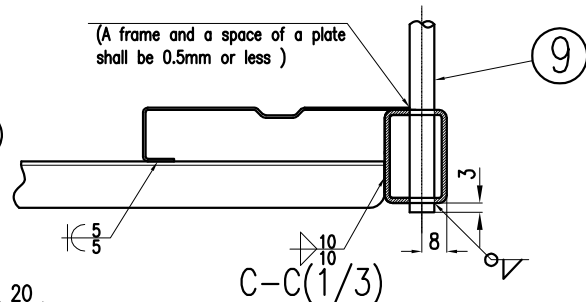
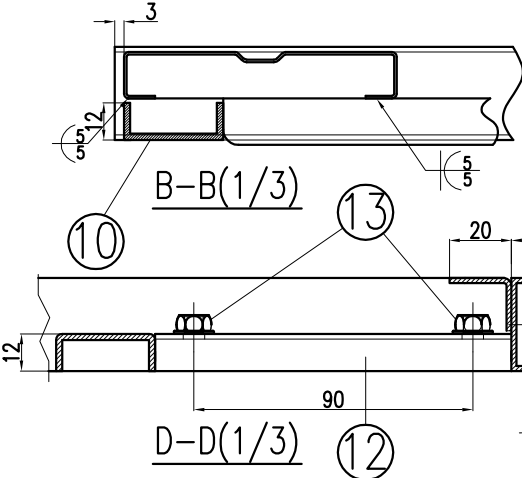
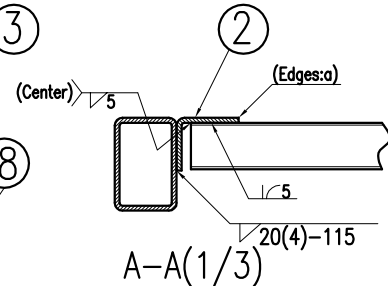
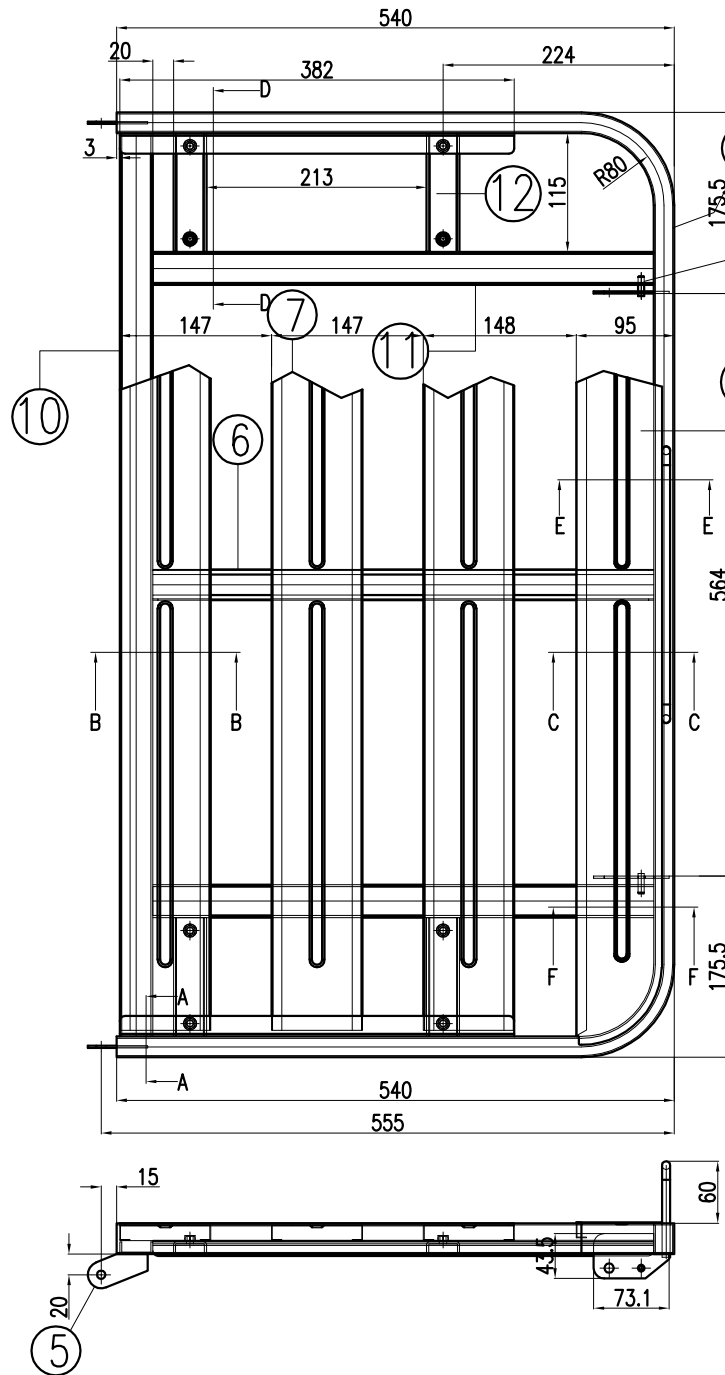

NO	CODE	COMPONENT	QTY	UNIT	COMPONENT SPESIFICATION
1	J-0020510	Frame	1	pcs	Pp. 30/20 x t 1.6 x (1886) 1874 (berdasarkan Trial WS)
2	.	Angle Optimus	F2	pcs	Pl. t 1.6 x 34 x 382 SPCC
3	K-005013	Roller Pin	2	pcs	Ø6 x 18 x (L)20 S20C
4	.	Roller Bracket	2	pcs	Pl. t 2.3 x 73 x 43.5 SPCC
5	K-200007	Hinge Plate	2	pcs	Pl. t 2.3 x 33 x 68 SPCC
6	.	Plate Frame Bottom C Multybed	H1	pcs	Pl. t 1.2 x 58 x 485 SPCC
7	K-202037	Sunoko Plate A	A3	pcs	Pl. t 0.7 x (134) x 861 SPCC
8	K-202038	Sunoko Plate B	1	pcs	Pl. t 0.7 x 110 x 890 SPCC
9	K-301002	Mat Guard	1	pcs	Ø8 x (464) SS400
10	.	Plate Frame 32/12 C	1	pcs	Pl. t 2.0 x (48) x 875, SPHC
11	.	Plate Frame 32/12 E	2	pcs	Pl. t 2.0 x (48) x 485, SPHC
12	.	Plate Frame 32/12 B	4	pcs	Pl. t 2.0 x (48) x 115, SPHC
13	.	Plange Nut	8	pcs	M6

NO	DATE	REMARKS	DRAWN	CHECKED	APPROVED	REVISED BY

Standard Application :		Specification :		MODEL :		Unit :	Paper :	Scale :	Projection :	Drawing Name :
-		-		.		mm	A4	1:X		BOTTOM C COMPL.
Drawn :	Designed/Customer :	Checked :	Approved :	Status :	Effective Date :	Page :	PT.Chitose Internasional Tbk.		Product Name :	
[I/A/N]	CM	M.Rosyidin	M.Rosyidin	PREPARATION DRAWING PRODUCTION DRAWING	11-02-2023	13	Research & Development Dept.		CB-3012/3003/3300 PLUS	