

CB-2003 D ST (MANUAL 3 CRANK)

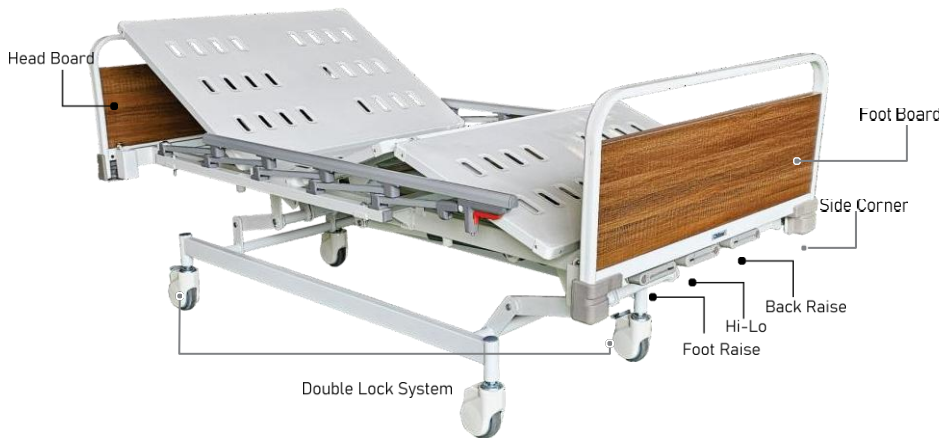

CB-2003 D ST is a 3 Crank manual hospital bed that meets your need. Suitable with folding side rail and Diagonal/Dual Lock System. **Equipment with 3 manual cranks** as the main mechanism to adjust the height, and head position of the bed, which can be adjusted manually for Patient's maximum comfort.

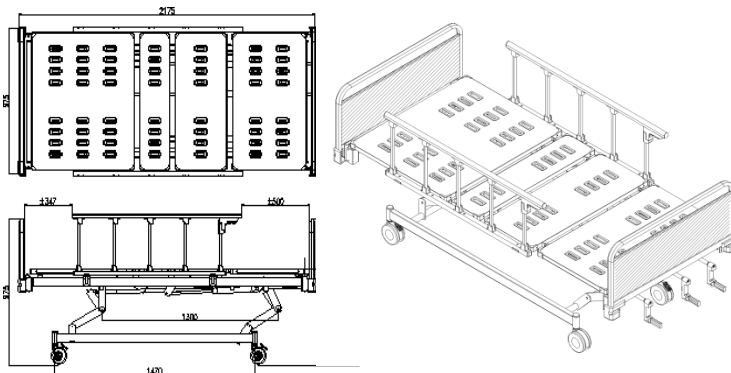

OPERATING SYSTEM



Adjustable Back Raise



Adjustable Foot Raise



Adjustable High/Low

PRODUCT SPECIFICATION

- Operating System : Adjustable Hi-Lo, Back Raise and Foot raise manual by crank
- Weight (Kg) : Approx. 90
- Accessories : FSR - 001
- Frame Finishing : Powder Coating
- Lock System : Double Lock System
- Frame Color : White
- Frame Material : Steel
- Dimension (mm) : Bed (W 1030, L 2230, H 760-1005)
H/F Board (W 932)
- Maximum static load : 250 Kg
- Safe Working Load (SWL) : 185 Kg

FEATURES



Cranks



Corner Bumper



Single Wheel Double Lock System

CB-2003 D ST (MANUAL 3 CRANK)

ACCESSORIES



FOLDING SIDE RAIL
Kode FSR 001

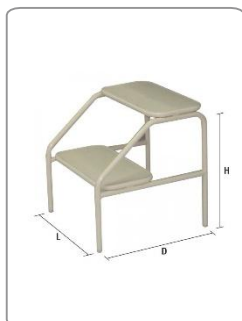

FOOTSTEP
Kode FS 001



MATRESS LATEX + POLIURETAN
Kode MT 005L

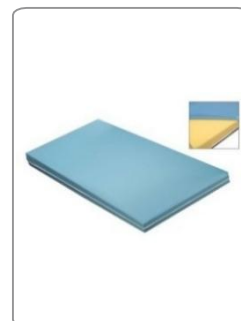

MATRESS POLYURETHANE
Kode MT 005U



TIANG INFUS 2 HOOK
Kode HR 001



TIANG INFUS 4 HOOK
Kode HR 002