

CB – 2300 D ST

CB 2300 D ST is an Electric Hospital Bed that meets your need. Suitable with Folding Side Rail and Diagonal/Dual Lock or Total Lock System. **Equipped with 3 Motors Actuator Operating System** as the main Mechanism to adjust the height, head, and foot position of the bed, which can be controlled by a handheld controller for Patient's maximum comfort.

Standard Function

Operating System	: 3 Motor electric operation for High-Low, Head Raise and Foot Raise positions
Position	: - High - low : Automatic operation with Motor - Head Raise : Automatic operation with Motor, tilting from 0 to 80 degrees - Foot Raise : Automatic operation with Motor, tilting from 0 to 80 degrees
Primary	: - Simple design, no sharp corners (smooth surface) - Easy operating mechanism, with Handheld controller - Sturdy and anti-rust - Wheels that are easy to move and position, with lock - unlock system
Lock System	: Double Lock System on the Wheels
Accessories	: IV Pole (2 Type Option) and Side Rail / Folding Side rail Bed Side Cabinet, Over Bed Table, and Foot Step Airmate Cpro Mattress / Urethane

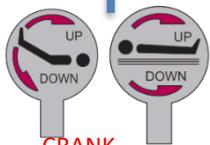
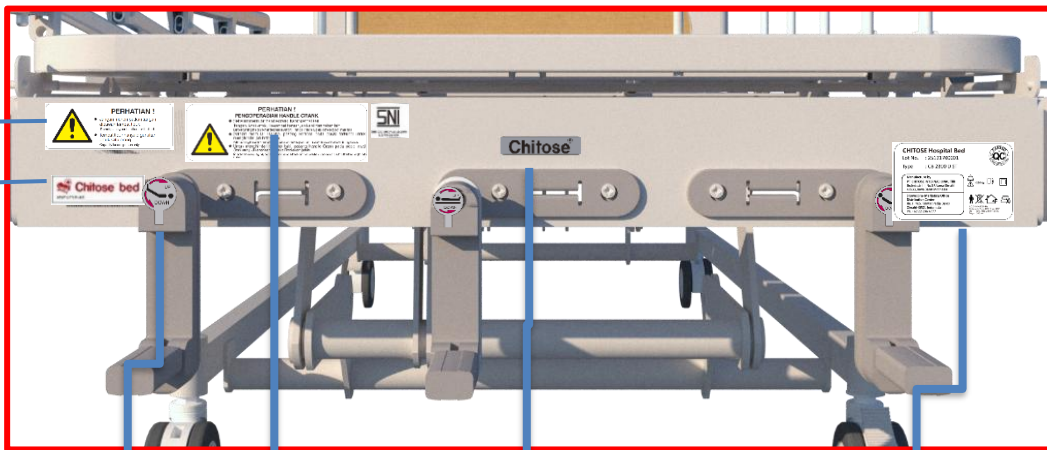

CRANK LABEL



**PERHATIAN !
PENGOPERASIAN HANDLE CRANK**

- Sebelum memutar handle crank, harap perhatikan: Tangan, Anak-anak, Hewan peliharaan, alat-alat dan bahan lain. Before turning the crank handle please watch: hands, children, pets, other tools or materials.
- Setelah memutar Handle, pasang kembali pada posisi terkunci untuk menghindari jatuh tiba-tiba. After turning the crank handle, put it back on locked position in order to avoid sudden falling down.
- Untuk menghindari terkena kaki, pasang Handle Crank pada posisi awal (terkunci). Jika terkena, maka Bed akan jatuh. In order to avoid leg hit, put the crank handle back on first position (locked). If it is hit, the bed might fall down.

Caution Handle operation



IZIN EDAR KEMENKES

PERHATIAN !

- Jangan menempatkan tangan dibawah tempat tidur. Do not place your hand under the bed
- Tempat tidur hanya digunakan untuk satu orang. Capacity for one person only

CAUTION LABEL

1 CHITOSE Hospital Bed
Lot No. : 25121700001
Type : CB 2300 D ST

2 Manufacture by
PT. CHITOSE INTERNASIONAL Tbk
Jln. Industri III No.5 Utama Cimahi
40533, Jawa Barat Indonesia

Showroom- Marketing Office
Distribution Center
Jln. H.M.S. Mintadiredja Baros
Cimahi 40521 Indonesia
Ph. +62 22 206 4777

3 =220 Kg

4

5

4

AC 230V~50/60 Hz
Duty cycle 2 min ON/18 min OFF
Int. : 10%, Max 2 min/ 18 min.
Days : 345 VA

PASSED by QC
CHITOSE INTERNATIONAL Tbk

MANUFACTURE LABEL AND LOT NUMBER

- 1** Lot Number and Product Type
- 2** Manufacture Information
- 3** Maksimum Weight Sign
- 4** Use Appropriate mattress Sign See Manual Instruction Sign
- 5** Applied Part Sign, Do not Dispose as Household Waste Sign Indoor Using Only Sign

CB-2300 D ST (ELECTRIC BED)

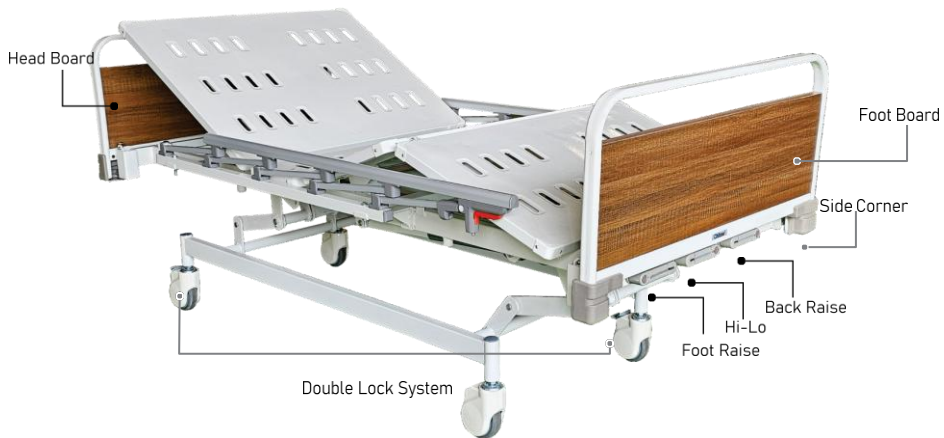

CB 2300 D ST is an Electric Hospital Bed that meets your need. Suitable with Folding Side Rail and Diagonal/Dual Lock or Total Lock System. **Equipped with 3 Motors Actuator Operating System** as the main Mechanism to adjust the height, head, and foot position of the bed, which can be controlled by a handheld controller for Patient's maximum comfort.

PRODUCT SPECIFICATION

- Operating System and : Adjustable H-Lo, Back Raise
Foot Raise Automatically by Motor
- Weight (Kg) : Approx. 90
- Accessories : FSR - 001
- Frame Finishing : Powder Coating
- Lock System : Double Lock System
- Frame Color : White
- Frame Material : Steel
- Dimension (mm) : Bed (W1030, L2230, H760-1005)
H/F Board (W932)
- Maximum Weight Load : 220 Kg

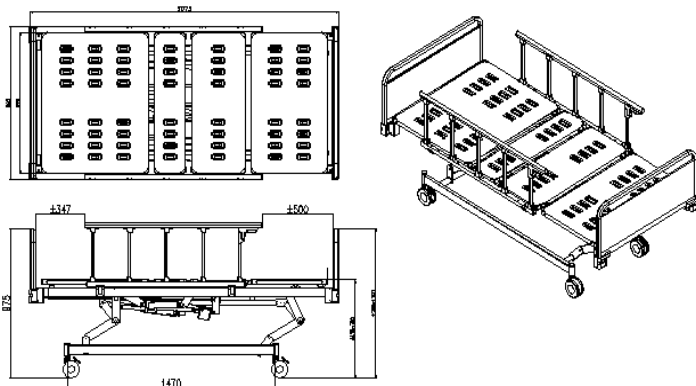

OPERATING SYSTEM



FEATURES

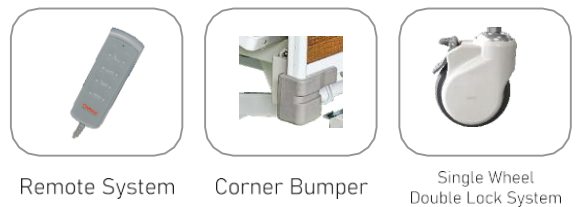

H/F BOARD OPTION



CB-2003 D ST (MANUAL 3 CRANK)

ACCESSORIES



FOLDING SIDE RAIL
Kode FSR 001

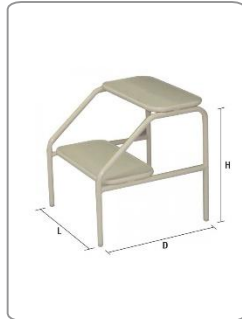

FOOTSTEP
Kode FS 001



MATRESS LATEX + POLIURETAN
Kode MT 005L



MATRESS POLYURETHANE
Kode MT 005U



TIANG INFUS 2 HOOK
Kode HR 001



TIANG INFUS 4 HOOK
Kode HR 002