

Description

Date : 13-Feb-20	Name : 1010AHD
Test No. : PQL200219680/VI/QC/02/20/GM2	Size : Ø05.25 mm
Part No./Heat No. : 2AV22	Customer/Supplier : MPF
Coil No. : VY579-01/007/02	

Item Check

<input type="checkbox"/> Tensile Strength Product	<input checked="" type="checkbox"/> Tensile Strength Material	<input type="checkbox"/> Proof Load
<input type="checkbox"/> Material Test Piece	<input type="checkbox"/> Part Test Piece	<input type="checkbox"/> Others

Remark

<input checked="" type="checkbox"/> Regular	<input type="checkbox"/> Trial	<input type="checkbox"/> Analysis	<input type="checkbox"/> Incoming	<input type="checkbox"/> Others
---	--------------------------------	-----------------------------------	-----------------------------------	---------------------------------------

Standard

YP Stress : ~	Max Force : ~	Max Stress : Min 30 Kgf/mm²
Elongation : ~	Reduction Of Area : ~	Others :

Method Reference : JIS Z 2201 : 1998	Shape : Rod
--------------------------------------	-------------

Test Result

Unit	Diameter (D) mm		Gauge Length (L) mm		Elongation %
	Original Diameter (D ₀)	Final Diameter (D _f)	Original Length (L ₀)	Final Length (L _f)	
Actual	5.235	3.230	100	103.79	3.79

Name	Unit	Actual
YP_Force	kgf	1297.94
YP_Stress	kgf/mm ²	60.30
YP_Strain	%	11.40
Max_Force	kgf	1321.17
Max_Stress	kgf/mm²	61.38
Max_Strain	%	12.07
Break_Force	kgf	833.33
Break_Stress	kgf/mm ²	38.72
Break_Strain	%	14.51
Re. of Area	%	61.93

Chart

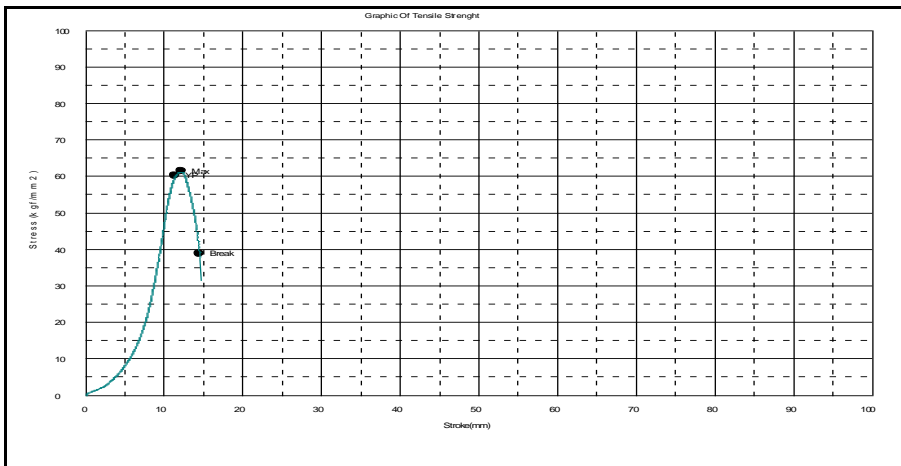

Illustration

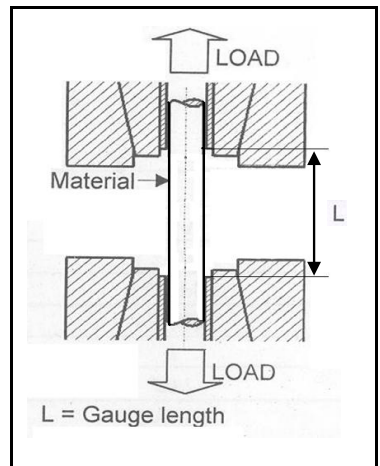

Note : No.Barcode : 20201204

	Inspected	Checked	Approved
Date	13-Feb-20	13-Feb-20	13-Feb-20
Signature	<i>[Signature]</i>	<i>[Signature]</i>	<i>[Signature]</i>
Name	Gusna	Supriyadi	Aris

Made	Date	Sign/Name	Revision	Date	Sign/Name	Judgement
	20/04/2011	Gusna/Supriyadi				<div style="display: flex; justify-content: space-around;"> <div style="border: 1px solid black; border-radius: 50%; padding: 10px; text-align: center;">OK</div> <div style="border: 1px solid black; border-radius: 50%; padding: 10px; text-align: center;">NG</div> </div>
Checked	21/04/2011	<i>[Signature]</i> / MPF				
Approved	25/4/11	<i>[Signature]</i> / Bernard				