

American National Standard for Office Furnishings

Desk/Table Products – Tests

Sponsor
BIFMA International
2680 Horizon Drive SE Suite A1
Grand Rapids, MI 49546-7500
(616) 285-3963
email@bifma.org
www.bifma.org

Approved January 2, 2008
American National Standards Institute

FOREWORD

The material presented in this standard was developed as a result of the efforts of BIFMA International members and reviewed by a broad representation of interested parties including government organizations, commercial testing laboratories, and procurement and interior design organizations.

This standard defines specific tests, laboratory equipment, conditions of test, and recommended minimum levels to be used in the test and evaluation of the performance, durability, and structural adequacy of desk/table products used in offices.

The original work on this standard was completed in 1980 by the BIFMA Engineering Committee and particularly by its Subcommittee on Desk/Table Standards. The Subcommittee on Desk/Table Standards conducts routine reviews of the standard to ensure that the tests accurately describe the proper means of evaluating the safety, durability, and structural adequacy of desk/table products.

The reviews produced revisions and/or additions to the various test procedures that improve the procedures and provide consistency. The most recent revisions were submitted to the membership of BIFMA International and approved in 2007. A canvass of interested parties and stakeholders was conducted in accordance with the requirements of an ANSI accredited standards developer.

After completion of the canvass process, the standard was subsequently submitted to the American National Standards Institute for approval as an American National Standard. Approval by ANSI was given on January 2, 2008.

Suggestions for the improvement of this standard are welcome. The suggestions should be sent to BIFMA International, 2680 Horizon SE, Suite A1, Grand Rapids, MI 49546-7500.

(Note: This foreword is not being considered for approval by ANSI)

Contents	Page
1 Scope	7
2 Definitions	8
3 General	13
3.1. Testing Considerations	13
3.2. Manufacturer's Instructions	14
3.3. Clearance Between Adjusting Surfaces	14
3.4. Figures	14
3.5. Figure Symbols	14
3.6. Tolerances	14
3.7. Pretest Inspection	15
3.8. Test Report Format	15
3.9. Loading Guidelines	18
4 Stability Tests	24
4.2. Stability with Extendible Elements Open Test	24
4.3. Stability Under Vertical Load Test	25
4.4. Horizontal Stability Test for Desks/Tables with Casters	26
4.5. Force Stability Test for Tall Desk/Table Products	28
5 Unit Strength Test	32
5.2. Concentrated Functional Load Test	32
5.3. Distributed Functional Load Test	37
5.4. Concentrated Proof Load Test	37
5.5. Distributed Proof Load Test	38
5.6. Transaction Surface Torsion Load Test	39
5.7. Extendible Element Static Load Test	40
6 Top Load Ease Cycle Test	42
7 Desk/Table Unit Drop Test	44
8 Leg Strength Test	48
9 Disengagement Test for Tall Desk/Table Products	51
10 Extendible Element Cycle Test	53
10.2 Cycle Test for Extendible Elements Deeper than Wide	53
10.3 Cycle Test for Extendible Elements Wider than Deep	54
10.4 Cycle Test for Center/Pencil Drawers	56
11 Extendible Element Retention Impact and Durability Test	58
12 Extendible Element Rebound Test	61
13 Interlock Strength Test	63

14	Lock Tests	65
	14.2 Force Test for Extendible Element Locks	65
	14.3 Force Test for Door Locks	66
	14.4 Locking Mechanism Cycle Test	68
15	Work Surface Vertical Adjustment Test	70
16	Keyboard Support and Input Device Support Adjustment Tests	73
17	Door Tests	74
	17.2 Strength Test for Vertically-Hinged Doors, and Vertically Receding Doors	75
	17.3 Hinge Override Test for Vertically-Hinged Doors	76
	17.4 Vertically Receding Doors Strength Test	77
	17.5 Horizontal Receding Doors Strength Test	79
	17.6 Wear and Fatigue Test for Hinged, Horizontal Sliding and Tambour Doors	81
	17.7 Wear and Fatigue Test for Vertical Receding Doors	83
	17.8 Wear and Fatigue Test for Horizontal Receding Doors	85
	17.9 Vertical and Horizontal Receding Door Out Stop Test – Cyclic Impact and Durability	87
	17.10 Slam Closed Test for Vertically Hinged and Vertically Receding Doors	89
	Drop Cycle Test for Horizontally Hinged and Horizontally Receding Doors	90
	17.11	91
	17.12 Slam Test for Doors that Free Fall Open or Closed	91
	17.13 Slam Open and Closed Test for Doors That Do Not Free Fall	92
	17.14 Door Latch Test	93
18	Durability Test for Desks and Tables with Casters	95
19	Pull Force Test	97
	Appendix A	99

Tables

1	Test Loads -All Categories of Horizontal Surfaces and Extendible Elements	20
2	Attachment Location for Pull Type	21
3	Drop Height for Desk/Table Units	43
4	Cycle Test for Extendible Elements Wider Than Deep	55
5	Door Test Applicability	74
6	Door Height vs. Load	75
7	Wear and Fatigue Tests for Doors	81
8	Desk/Table Movement Cycle Test Parameters	95

Figures

3	Loading Configurations for Extendible Elements	
3a	Loading Configurations for Ext. Element (Deeper than Wide) with Bottoms	16
3b	Loading Configurations for Ext. Element (Wider than Deep) with Bottoms	16
3c	Loading Configurations for Ext. Element (Deeper than Wide) without Bottoms	17
3d	Loading Configurations for Ext. Element (Wider than Deep) without Bottoms	17
4	Stability Tests	
4a	Stability with Extendible Elements Open	22
4b	Stability Under Vertical Load	22
4c	Stability Loading for Irregular Shaped Tables	23
4d	Horizontal Stability Test for Desk/Tables with Casters	26
4e	Force Stability Test for Tall Desk/Table Products	28
5	Unit Strength Tests	
5a	Concentrated Load Tests for Primary Surfaces	30
5b	Top View of Placement of Concentrated Load(s)	30
5c	Top View of Ganged Units Surface Size Determination	31
5d	Top View of Dual Concentrated Load Tests	31
5e	Distributed Load Tests for Primary Surfaces	34
5f	Distributed Load Test for Secondary Surfaces	34
5g	Top View of Distributed Load Tests for Primary Surfaces	35
5h	Distributed Load Tests for Adjustable Keyboard Supports	36
5i	Transaction Surface Torsion Load Test	39
6	Top Load Ease Cycle Test	41
7	Desk/Table Unit Drop Test	43
8	Leg Strength Test - Typical Configurations/Load Application	45-47
9	Disengagement Test for Tall Desk/Table Products	50
10	Extendible Element Cycle Test	52
11	Extendible Element Retention Impact and Durability Test	
11a	Extendible Element Retention Impact Test	57
11b	Extendible Element Retention Durability Test	57
12	Extendible Element Rebound Test	60
13	Interlock Strength Test	62

14	Lock Tests	
14a	Force Test for Extendible Element Locks	64
14b	Force Test for Door Lock	66
14c	Locking Mechanism Cycle Test	67
15	Work Surface Vertical Adjustment Tests	69
16	Keyboard Support and Input Device Support Adjustment Tests	72
17	Door Tests	
17a	Strength Test for Vertically Hinged Doors, Bi-fold Doors and Vertically	75
17b	Receding Doors	76
17c	Hinge Override Test for Vertically Hinged Doors	77
17d	Vertically Receding Doors Strength Test	78
17e	Horizontal Receding Doors Strength Test	80
17f	Wear and Fatigue Test for Hinged, Horizontal Sliding and Tambour Doors	82
17g	Wear and Fatigue Test for Vertical Receding Doors	84
17h	Wear and Fatigue Test for Horizontal Receding Doors	86
17i	Receding Door Out Stop Test-Cyclic Impact	86
17j	Receding Door Out Stop Test-Cyclic Durability	88
17k	Slam Closed Test for Vertically Hinged and Vertically Receding Doors	90
17l	Drop Cycled Test for Horizontally Hinged and Horizontally Receding Doors	91
17m	Slam Test for Doors Which Free Fall Open or Closed	92
	Slam Open and Closed Test for Doors That Do Not Free Fall	
18	Durability Test for Desks and Tables with Casters	94
19	Pull Force Test	97

American National Standard for Office Furnishings

Desk/Table Products – Tests

1 Scope

This standard provides a common basis for evaluating the safety, durability and structural performance, including reasonably foreseeable misuse, of desk/table products intended for use in commercial office and related institutional environments.

It provides test methods and performance requirements for desk/table products. Where a product may be covered by more than one ANSI/BIFMA standard, the manufacturer shall determine which standard provides most appropriate test conditions. Where a product is intended for use outside of the commercial office and related institutional environments, it is the responsibility of the user of this standard to determine if it is suitable for use in such evaluations.

This standard specifies acceptance levels to help ensure reasonable safety and performance independent of construction materials, manufacturing processes, mechanical designs, or aesthetic designs. These tests are not intended to assess a product that has been in use. The acceptance levels herein are based on the actual field and test experience of BIFMA International members.

ISO 17025 requirements for reporting uncertainty do not apply when determining conformance to this standard.

2 Defintions

Note : Refer to BIFMA PD-1 Industry Product Definitions for related terms not included in this standard. Otherwise, the common dictionary definition shall be used for terms not defined in this section or in BIFMA PD-1.

In the case of a conflict between the definitions in this standard and PD-1, the definitions in this standard shall apply.

- 2.1. acceptance level:** The performance level required to pass the test.
- 2.2. accessory item:** Items such as hanging rail bars, divider plates, and other items supplied by manufacturers for the convenience of the users of the products.
- 2.3. adjustable glides:**Support devices for leveling and/or stabilizing a desk/table product. (Alternately referred to as "glides," "levelers," "adjustable supports," or "height adjusters.")
- 2.4. anti-rebound:** The feature that ensures that an extendible element will stay closed and will not roll or bounce out of the compartment.
- 2.5. categories of desks or tables:**
- 2.5.1 category I:** Desks or tables with surfaces greater than 610 mm (24 inches) in height and have a total work surface area greater than 0.46 m²(5 ft.2).
- 2.5.2 category II:** Desks or tables with surfaces which are always less than or equal to 610 mm (24 inches) in height.
- 2.5.3 category III:** Desks or tables with surfaces greater than 610 mm (24 inches) in height and have a total work surface area less than or equal to 0.46 m²(5 ft.2).
- Note:**
The highest position of adjustable work surfaces is used to define the category. If a desk or table has multiple surfaces, its highest primary surface shall be used to define its category.
- 2.6. center/pencil drawers:** A drawer, with a clear height less than 76 mm (3 in.), attached to a desk or table or is part of a desk pedestal which is primarily intended for the storage of light office supplies (such as pencils, pens, erasers, staples, etc.)
- 2.7. clear dimensions:** The clear dimensions of the extendible element or desk/table component are defined by the sides of the largest rectilinear box (with specific height limitations as noted in 2.7.2 below) that fits into the space. For extendible elements, the box must clear all stationary elements as the extendible element is taken through its full range of travel. These dimensions are used to calculate extendible element test loads.
- 2.7.1 clear depth:**The horizontal dimension of the box (as defined in 2.7) in the direction of travel. The clear depth is not reduced by the presence of a compressor.

2.7.2 clear height: The vertical dimension of the box (as defined in 2.7).

Exceptions :

- In the case where there is no bottom for the extendible element, the maximum clear height value used for the clear space calculation shall not exceed 305 mm (12 in.).
- In the case where there is a unit bottom the maximum clear height value used for the clear space calculation shall not exceed 457 mm (18 in.).
- For shelves that extend, the maximum clear height value used for the clear space calculation shall not exceed 305 mm (12 in.).

2.7.3 clear width: The horizontal dimension of the box (as defined in 2.7) at right angles to direction of travel.

2.8 clear space: The volume defined by the product of the clear dimensions.
For example: clear space = (clear depth) x (clear width) x (clear height).

2.9 closed: The extendible elements of the unit are fully retracted into the case and/or doors are in the position, blocking entry into the desk/table product.

2.10 compartments: The areas into which the unit is divided.

2.11 compressor: A device used to restrict the movement of the filed material.

2.12 credenza: A unit with desk pedestals, generally 457 mm to 610 mm (18 in. to 24 in.) deep, used in combination with or connected to the desk unit for additional storage.

2.13 cycle: A complete operation of loading and unloading or of stress reversal; to open and close; one complete revolution; to operate in a cyclic fashion.

2.14 depth: The horizontal dimension from front to rear. This may be applied to either the unit or to the extendible elements, so it shall be specifically identified and described.

2.15 desk: An article of furniture having a primary work surface that is between 660 mm (26 in.) and 965 mm (38 in.) high and is supported by legs and/or storage component(s) with or without extendible element(s) and with a knee space.

2.16 desk extension: A unit that is generally attached to a desk to create a work surface that extends from the desk workstation. (Also known as an "extended desk unit").

2.17 desk/table product: Freestanding furniture articles including but not limited to, single and double pedestal desks, extended desk units, credenzas, and tables.
Also included are items such as overhead storage units, hutches, screens, etc., that are either attached to, placed on or supported by the desk/table unit. Paper management products (horizontal, vertical and diagonal paper trays), small storage bins and desk accessories (telephone trays, pencil holders and paper clip holders, etc.) and similar items are not considered desk/table products and are not included in this standard.

- 2.18 Door :** A barrier by which an area is closed or opened. Types include: horizontal receding, vertical receding, tambour, sliding, vertical swinging, horizontal swinging, bi-fold, accordion, and others.
- 2.19 extendible element:** A movable load bearing storage component, including, but not limited to: drawers, shelves, and filing frames. This excludes doors, writing shelves, and adjustable keyboard supports.
- 2.20 force:** A vector quantity, expressed in newton (N) or pounds-force (lbf.) that tends to produce an acceleration of a body in the direction of its application.
- 2.21 fully extended:** The extendible element pulled out to the limit of its stops.
- 2.22 functional load:** A level of loading intended to be typical of hard use.
- 2.23 ganged units:** Two or more units fastened together.
- 2.24 hutch:** A non-freestanding storage unit that is mounted on a primary work surface(s). Also known as service modules, shelving units, risers, overhead storage units, etc.
- 2.25 input device support:** A surface that is occupied exclusively by computer input devices such as computer mice, trackballs, and light pens.
- 2.26 Interlock :** A device that limits the extension of one or more extendible elements to maintain stability of the unit.
- 2.27 lbf.:** Abbreviation for pounds-force. The corresponding unit in the SI (Système International), also known as the Metric System, is the newton (N).
- 2.28 leg:** A support member of a desk, credenza, or table.
- 2.29 length:** The measure of something along its greatest horizontal dimension. This may be applied to either the unit or to the extendible elements, so it shall be specifically identified and described.
- 2.30 leveled:** A condition where the desk/table product, when installed, adopts and maintains a true horizontal and vertical attitude. Leveling may be accomplished by, but not limited to, the use of adjustable glides or shimming.
- 2.31 load:** The weight to which a structure is subjected; a weight or force applied to a product; force acting on a surface, usually caused by the action of gravity.
- 2.32 Lock :** A device that secures the stationary and extendible elements of the desk/table unit against undesired access or opening.
- 2.33 loss of serviceability:** The failure of any component to carry its intended load or to perform its normal function or adjustment. Unless otherwise specified, cracked or broken glass is considered a loss of serviceability.
- 2.34 N (newton):** A unit of force in the SI (Système International), also known as the Metric System.

- 2.35 out stops:**A device that limits the travel of the extendible element in a direction away from the unit.
- 2.36 pedestal:**A self-contained unit that is less than 787 mm (31 in.) in height with a depth equal to or greater than its width, and having extendible elements or doors. The extendible elements are typically used for multi-functional general storage or filing. It may be freestanding, mounted under a horizontal surface, or mobile. Pedestal tops may be configured to accommodate seating or storage.
For the purpose of this standard, pedestals pertain only to those items mounted under a horizontal surface.
- 2.37 product safety label:**A sign, label, cord-tag or decal affixed to the product that provides safety information about that product. Product safety signs or labels may identify the hazard, the degree or level of seriousness, the probable consequences of involvement with the hazard, and how the hazard can be avoided.
- 2.38 proof load:** A level of loading or force in excess of hard use.
- 2.39 pull:**A feature used to facilitate the opening and closing of an extendible element or door. Pull refers to both projecting and recessed features.
- 2.40 screen:**Non-load-carrying space divider that is less than ceiling height.
- 2.41 stability:**The ability of a unit to resist tipping under normal loading and use conditions.
- 2.42 stops:** Devices that limit travel of extendible elements or doors.
- 2.43 support element:** A part of the unit or table that keeps the unit elevated above the floor.
- 2.44 surface classifications:**
- 2.44.1 adjustable keyboard support surface:**An adjustable surface that is intended for placement of the keyboard, and/or other computer input devices.
- 2.44.2 display shelf:**A shelf with a sloping surface and retaining flange or edge.
- 2.44.3 door shelf:** A shelf attached to a door. A display shelf that functions as a door is also considered a door shelf.
- 2.44.4 primary surface:** A surface that has the apparent potential for the highest loading or a surface on which a person may sit (less than 965 mm [38 in.] high). In cases where more than one horizontal surface of a unit exists, there may be more than one primary surface.
- 2.44.5 secondary surface:**A surface that is vertically separated from and smaller than the primary work surface(s). It is used for storage (that is, a shelf) or occupied exclusively by the equipment placed on the surface.
Note:If it is unclear whether a surface is primary or secondary, the surface shall be considered primary.
- 2.44.6 transaction surface:**A surface that may be vertically separated from and smaller than the primary work surface(s). It is used for short-term placement of documents, packages and similar items being immediately transferred between users, and/or for placement of lightweight displays and decorative items. It is typically accessible in the user position and the approach position simultaneously.

- 2.44.7 writing shelf:** A moveable, typically stowable surface that is not intended to carry loads greater than defined in Table 1 (See page 20), whose primary function is to support ancillary office tasks, such as writing and short-term reference material handling.
- 2.45 suspension:** The system that is used to facilitate the movement of the extendible element in and out of the unit (alternately referred to as "slides").
- 2.46 table:** A freestanding unit having a work surface supported by legs. Attached storage is limited to center/pencil drawers.
- 2.47 tall desk/table product:** Any desk/table unit that is higher than 1067 mm (42 in.) tall.
- 2.48 test platform:** The horizontal hard work surface, (concrete or other unyielding surface) on which the unit to be tested is placed during testing.
- 2.49 tip over:** The condition where the unrestricted unit will not return to its normal upright position.
- 2.50 unit:** When used in the test procedures in this standard, unit refers to the product to be tested. In the case where individual components can be combined, the combined assembly shall be considered a unit.
- 2.51 unit height:** the vertical distance of a unit from the floor or test platform to its highest point. The height measurement is taken with adjustable glides at the midpoint of their adjustment but not to exceed 13 mm (0.5 in.).
- 2.52 unsupported span:** The distance between adjacent floor supports. Pedestals or other structures not extending to the floor do not affect this distance.
- 2.53 user adjustable surfaces:** A surface that is intended to be adjusted by the user while under normal use.
- 2.54 width:** A horizontal dimension from side to side. This may be applied to either the desk product or to the extendible elements, so it shall be identified and described.
- 2.55 working edge:** The side of the surface at which the primary user sits.
Note: some surfaces may have more than one working edge; conference tables for example.
- 2.56 worst-case condition:** The condition (i.e. size and construction of a given unit type) most likely to be adversely affected by the test.

3 General

3.1. Testing Considerations

- 3.1.1.** The testing and evaluation of a product in accordance with this standard may require the use of materials and/or equipment that could be hazardous. This document does not purport to address all the safety aspects associated with its use. Anyone using this standard has the responsibility to consult the appropriate authorities and to establish health and safety practices in conjunction with any applicable regulatory requirements prior to its use.
- 3.1.2.** The types of tests to be employed fall into the following general categories:
- a) static load applications;
 - b) dynamic load applications
 - c) Durability tests
- 3.1.3.** Each manufacturer's model or unit type in any configuration shall comply with applicable requirements when tested in accordance with this standard. Only worst-case models need to be tested for a specific unit type. A worst-case condition shall be representative of all models or units of the type tested. If the "worst-case condition" is not readily evident, a case-by-case product line analysis by the manufacturer in consultation with the designated testing facility may be necessary, taking into consideration any special attributes, methods of construction, materials, and/or design features, etc.
- 3.1.4.** Unless otherwise specified within an individual test section, only the worst-case component(s) (extendible element, door, etc.) per unit need be tested. This will typically be the largest component(s) of each construction/mounting type. If the worst-case condition is not readily evident, multiple components may require testing.
- 3.1.5** Tests may be conducted on a single unit or a series of units with the following exceptions:
- functional loads and proof loads shall be applied to the same components in the same unit.
 - strength tests of leg assemblies of identical construction must be performed on a single leg.
- 3.1.6** If components are intended to be attached to the desk/table unit, the entire unit including interfacing hardware and/or brackets must meet the applicable static loading and durability tests within this standard.
- 3.1.7** The tests may be conducted in any sequence

3.2. Manufacturer's Instructions

When a manufacturer provides specific assembly/installation instructions, product safety labels, or maintenance adjustments that may be required in order to keep the product in good operating condition, these instructions shall be followed during testing unless otherwise specified by the test procedures herein.

3.3. Clearance Between Adjusting Surfaces

The clearance between a vertically user-adjustable surface and any adjacent surface shall not be less than 25 mm (1 in.).

A clearance less than 8 mm (0.3 in.) is acceptable where the clearance is maintained throughout the travel of the adjusting surface. Articulating keyboard support surfaces are exempt from this requirement

3.4. Figures

Figures provided in this standard are guidelines only and are not representative of all possible test configurations.

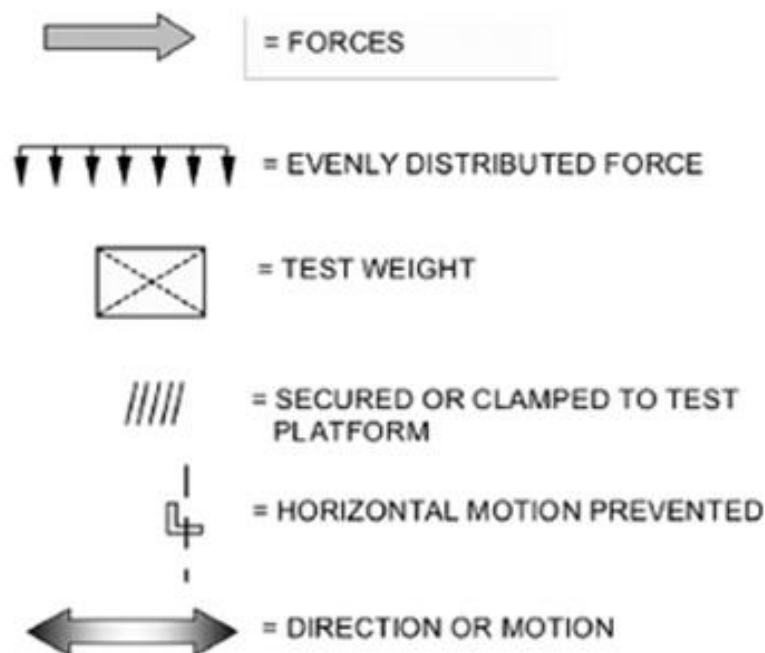
3.5. Figure Symbols**3.6. Tolerances**

Unless otherwise specified, tolerances on test equipment, measuring equipment and loading devices, shall be:

- Test weights, forces, velocities, and time, $\pm 5\%$
- Linear measurements, ± 1.5 mm (0.06 in.)
- Angles, ± 5 degrees
- Level, within 5 mm per meter (0.06 in. per linear foot)
- Cycle requirements are minimums

Test weights, forces, dimensions, angles, time, rates and velocities shall be targeted at the nominal values specified.

3.7 Pretest Inspection

Before beginning the testing, visually inspect the unit thoroughly. Record any defects so that they are not assumed to have been caused by the tests.

3.8. Test Report Format

When a test report is required, the following information should be included:

1. A title: (i.e., "Test Report");
2. Name and address of the laboratory, and the location where the tests were carried out, if different from the address of the laboratory;
3. Unique identification of the report (such as serial number) and on each page an identification in order to ensure that the page is recognized as part of the test report and a clear identification of the end of the test report;
4. Name and address of the client (where applicable);
5. Description and unambiguous identification of the item tested (i.e., model number, manufacturing date, etc.);
6. Characterization and condition of the test item;
7. Date of receipt of the test item;
8. Date(s) of the performance of test;
9. Identification of the test method used
10. Any additions to, deviations from, or exclusions from the test method (such as environmental conditions);
11. The name(s), function(s) and signature(s), or equivalent identification of the person(s) authorizing the test report;
12. Where relevant, a statement to the effect that the results relate only to the items tested;
13. Date of issue of the report;
14. Test results with, where appropriate, the units of measurement and a statement of compliance/non-compliance with requirements and/or specifications;
A statement that the report shall not be reproduced, except in full, without the written approval of the laboratory.
- 15.

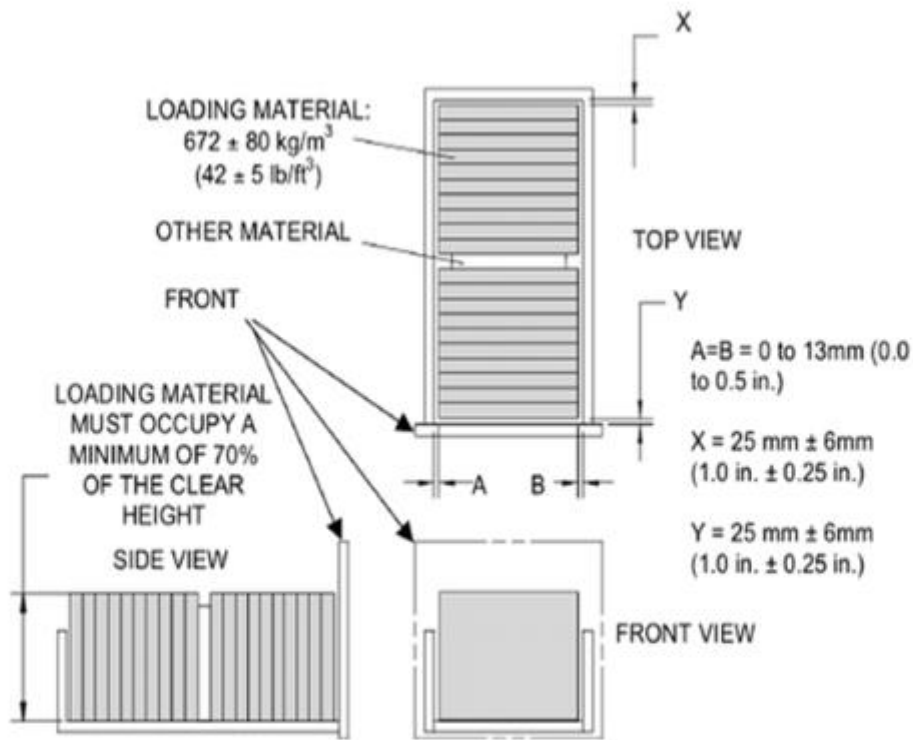

Figure 3a - Loading Configuration for Extendible Elements (Deeper than Wide) with Bottoms

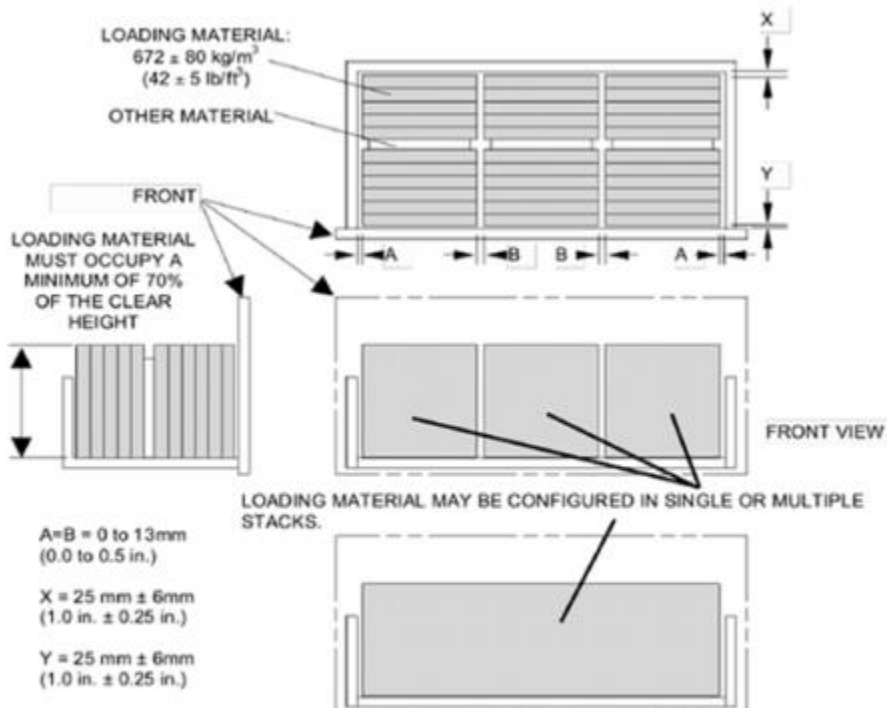

Figure 3b - Loading Configuration for Extendible Elements (Wider than Deep) With Bottoms

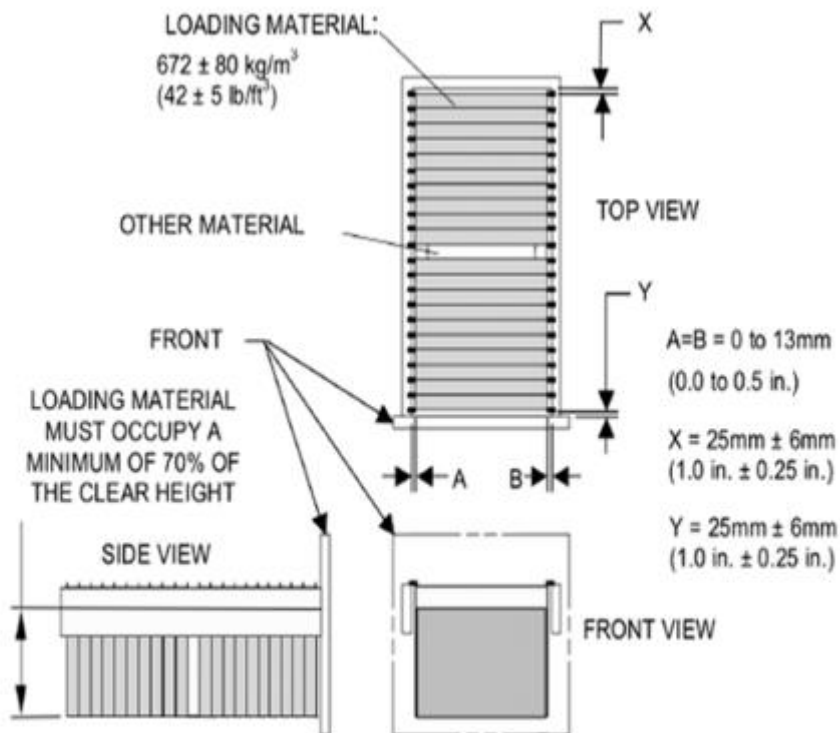

Figure 3c - Loading Configuration for Extendible Elements (Deeper than Wide) without Bottoms

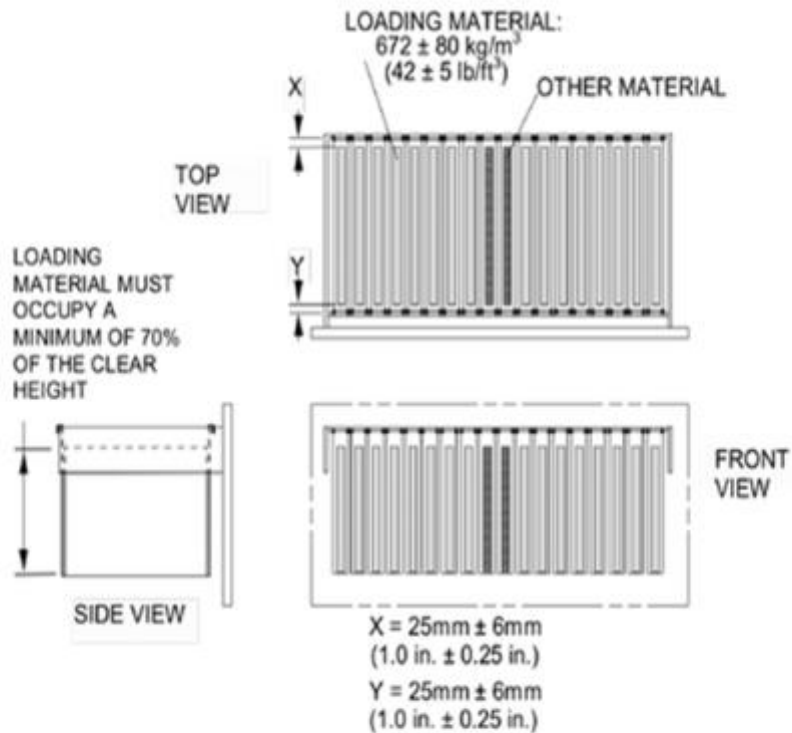

Figure 3d - Loading Configuration for Extendible Elements (Wider than Deep) Without Bottoms

3.9. Loading Guidelines

3.9.1. Loading Material for Extendible Elements

The functional loading material shall have a density of $672 \pm 80 \text{ kg/m}^3$ ($42 \pm 5 \text{ lb./ft.}^3$). A typical loading material could be 721 kg/m^3 (45 lb./ft.^3) industry standard particleboard or typical bond copier paper.

The loading material size may be adjusted to accommodate the size of the extendible element to be tested. If necessary, up to 15% of the weight may be made up of higher density plates placed on edge centered between the other loading material.

For extendible elements with clear heights greater than 216 mm (8.5 in.) the loading material shall be placed on its edge to minimize deflection of the extendible element bottom. For extendible elements with clear heights less than 216 mm (8.5 in.) the loading material does not need to be placed on its edge.

Note: Higher density materials may be used for proof loads.

3.9.2 Loading Material for Other Than Extendible Elements

Loading material of any density that meets the weight requirements of the test may be used.

(Examples: concrete bricks, shot bags, metal plates, sand bags, typical bond copier paper, etc.).

3.9.3 Loading Guidelines for Extendible Elements with Bottom Supported Loads (See Figures 3a and 3b)

The clear space within an extendible element shall be loaded using the materials specified in Section 3.9.1. The loading material shall be uniformly distributed front to rear, and side-to-side in the bottom of the extendible element. The air gap in the front and the air gap in the rear shall each be $25 \text{ mm} \pm 6 \text{ mm}$ ($1.0 \text{ in.} \pm 0.25 \text{ in.}$). The volumetric distribution of the loading materials may be adjusted with the use of rigid materials (such as expanded polystyrene foam, steel, etc. – see “other materials” in Figures 3(a-d)) in order to obtain the specified front and rear air gaps.

The front and rear air gaps shall be free of any materials. See Figure 3a for extendible elements which are deeper than wide. See Figure 3b for extendible elements which are wider than deep.

3.9.4. Loading – Guidelines for extendible elements for hanging-file supported loads (See Figure 3c and 3d)

The loading material specified in Section 3.9.1 shall be placed in hanging file folders of the appropriate size. The loading material shall be uniformly distributed front to rear, and side-to-side. The air gap in the front and the air gap in the rear shall each be $25 \text{ mm} \pm 6 \text{ mm}$ ($1.0 \text{ in.} \pm 0.25 \text{ in.}$). The volumetric distribution of the loading materials may be adjusted with the use of rigid materials (such as expanded polystyrene foam, steel, etc. – see “other materials” in Figures 3a-d) in order to obtain the specified front and rear air gaps. The front and rear air gaps shall be free of any materials. See Figure 3c for extendible elements which are deeper than wide. See Figure 3d for extendible elements which are wider than deep.

Note: Where extendible elements have the capability of supporting loads both on the bottom and in hanging folders, test in accordance with 3.9.3.

3.9.5. Load Application

Loads may be secured to surfaces, excluding extendible elements. The method of securing the loads shall not enhance or compromise the structure of the component(s) being tested. When loads are applied through load disks, the load shall be centered on the disk.

3.9.6. Test Force Application

To ensure that negligible dynamic force is applied, the forces in the static force tests shall be applied sufficiently slowly until the target load/force is achieved.

Where time limits are given, loads and forces shall be maintained according to the tolerance given in Section 3.6 unless otherwise specified.

Table 1
Test Loads - All Categories of Horizontal Surfaces and Extendible Elements

Surface Class	Surface Size	Functional Load		Proof Load	
		Concentrated	Distributed	Concentrated	Distributed
Primary	Length \leq 1143 mm (length \leq 45 in.)	91 kg (200 lb.)	N/A	136kg (300 lb.)	N/A
Primary	1143mm < length \leq 1829 mm (45 in. < length \leq 72 in.)	91 kg (200 lb.)	0.027 kg/mm of perimeter (1.5 lb./in. of perimeter)	136kg (300 lb.)	0.041 kg/mm of perimeter (2.3 lb./in. of perimeter)
Primary	Length > 1829 mm (length > 72 in.)	Two loads of 91 kg (200 lb.) each	0.027 kg/mm of perimeter (1.5 lb./in. of perimeter)	Two loads of 136 kg (300 lb.) each	0.041 kg/mm of perimeter (2.3 lb./in. of perimeter)
Secondary, Transaction and Shelf	Calculate load based on the height of the available space above the surface ¹ , but not > 305mm (12 in.)	N/A	470 kg/m ³ (0.017 lbs./in. ³)	N/A	720 kg/m ³ (0.026 lb./in. ³)
Display Shelf	All Sizes	N/A	0.027 kg/mm (1.5 lb./in.)	N/A	0.040 kg/mm (2.25 lb./in.)
Storage/Hutch Top	Unit height \leq 1524 mm (60 in.)	N/A	141 kg/m ² (0.20 lb./in. ²)	N/A	211 kg/m ² (0.30 lb./in. ²)
Storage/Hutch Top	Unit height > 1524 mm (60 in.)	N/A	63 kg/m ² (0.09 lb./in. ²)	N/A	99 kg/m ² (0.14 lb./in. ²)
Door Shelf	All Sizes	N/A	0.018 kg/mm (1 lb./in.)	N/A	N/A
Extendible Element	Calculate load based on the clear space	N/A	470 kg/m ³ (0.017 lb./in. ³)	N/A	720 kg/m ³ (0.026lb./in. ³)
Center/Pencil Drawer	All sizes	N/A	2.3 kg (5 lb.)	N/A	N/A
Adjustable Keyboard Support	Width \leq 914 mm (width \leq 36 in.)	N/A	30 kg (66 lb.)	N/A	45 kg (100 lb.)
Adjustable Keyboard Support	Width > 914mm (width > 36 in.)	N/A	45 kg (100 lb.)	N/A	68 kg (150 lb.)
Writing Shelf	All Sizes	N/A	11 kg (25 lb.)	N/A	N/A

Note: See Section 2.44 for definitions of surface classifications.

¹ The available space above the surface shall be determined using the concept of the largest rectangular box that will fit into the space. This concept is similar to that described in Section 2.7 "Clear Dimensions".

Table 2
Attachment Location for Pull Type

Pull Type/Position	Device Attachment
Narrow pull \leq 33% of extendible element/door front width or height (center pulls and single side pulls)	Center of pull area.
Wide Pull $>$ 33% of extendible element/door front width or height	Three areas (one at a time): 1) Center of pull area. 2) At a distance from the right hand edge (or top of the door for horizontally sliding doors) of the extendible element/door front equal to one-sixth of the extendible element/door front width (or height for horizontal sliding doors) \pm 6 mm (0.25 in.) or from one end of the pull, whichever is a greater distance from the edge/top of the extendible element/door. 3) At a distance from the left hand edge (or bottom of the door for horizontally sliding doors) of the extendible element/door front equal to one-sixth of the extendible element/door front width (or height for horizontal sliding doors) \pm 6 mm (0.25 in.) or from one end of the pull, whichever is a greater distance from the edge/bottom of the extendible element/door.
Dual Side Pulls	Center of the right hand pull and then the center of the left hand pull.

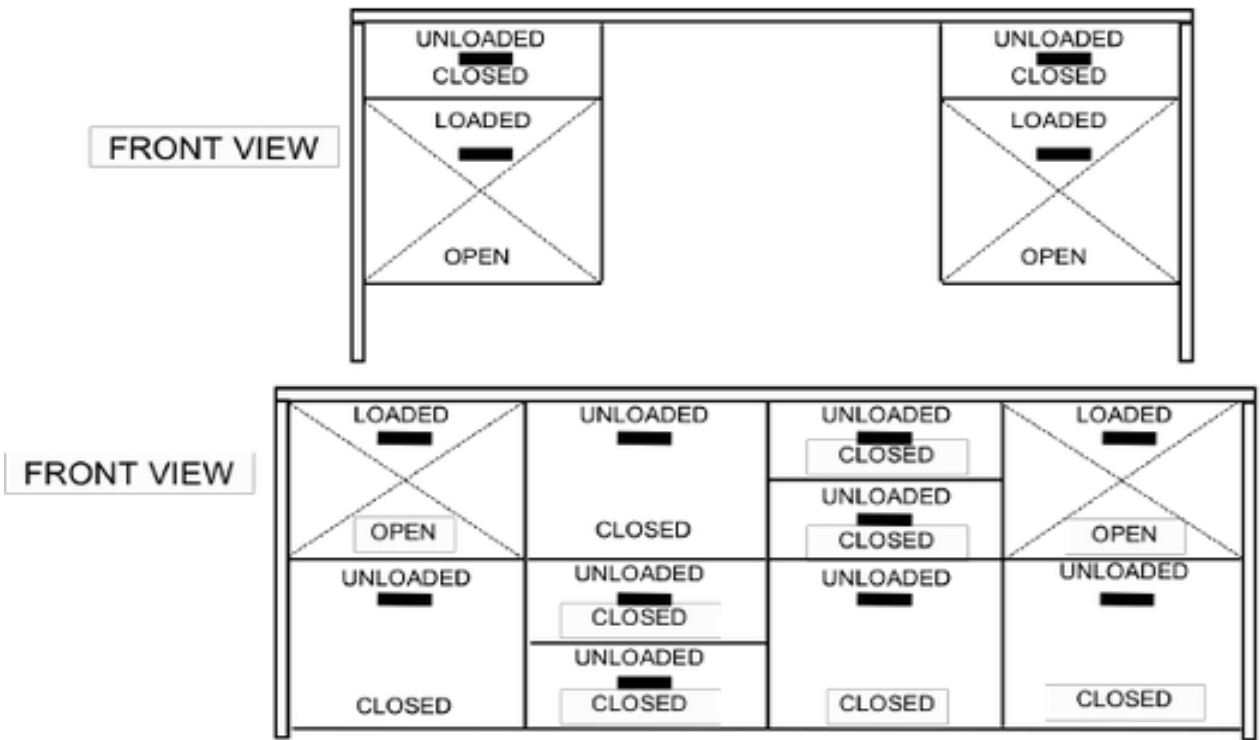

Figure 4a - Stability with Extendible Elements Open

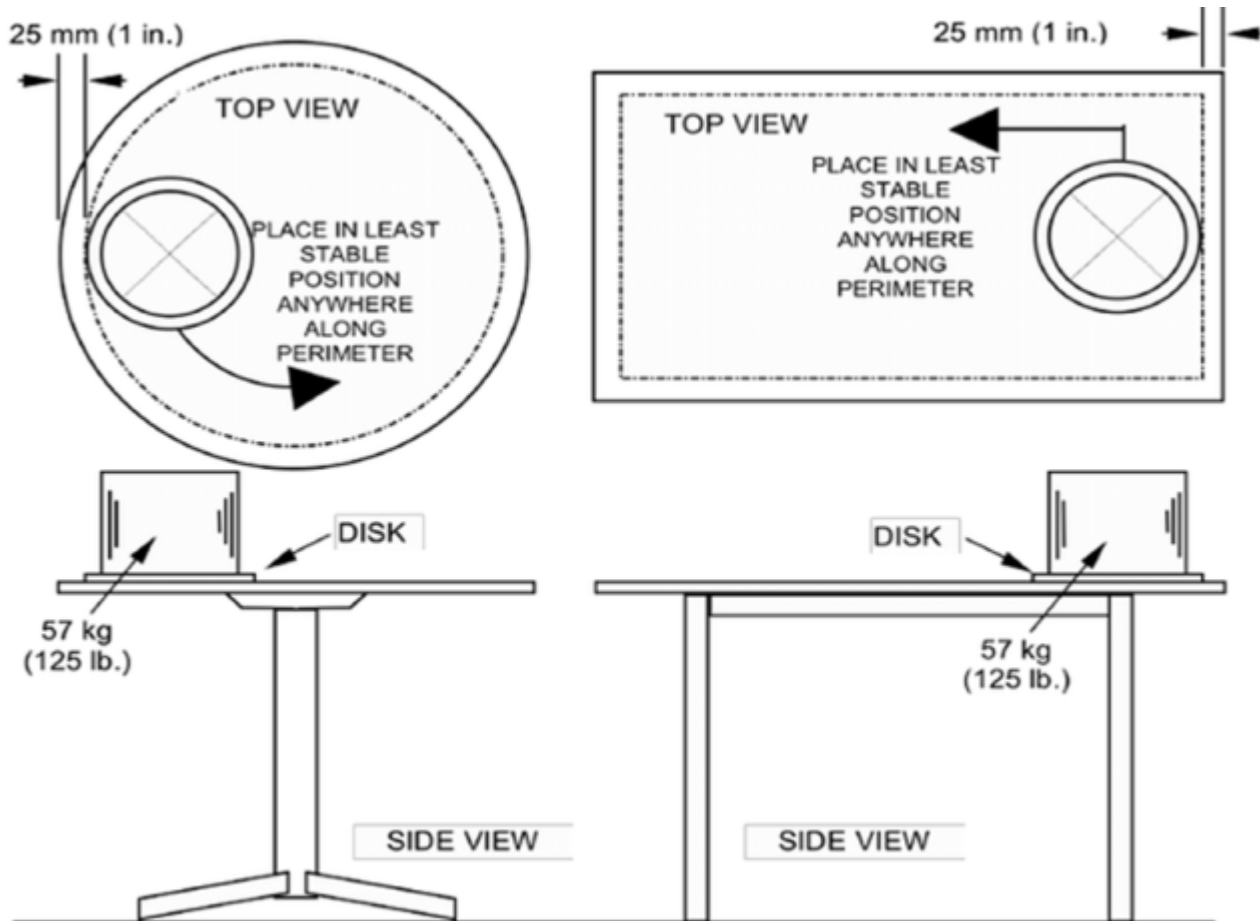

Figure 4b - Stability Under Vertical Load

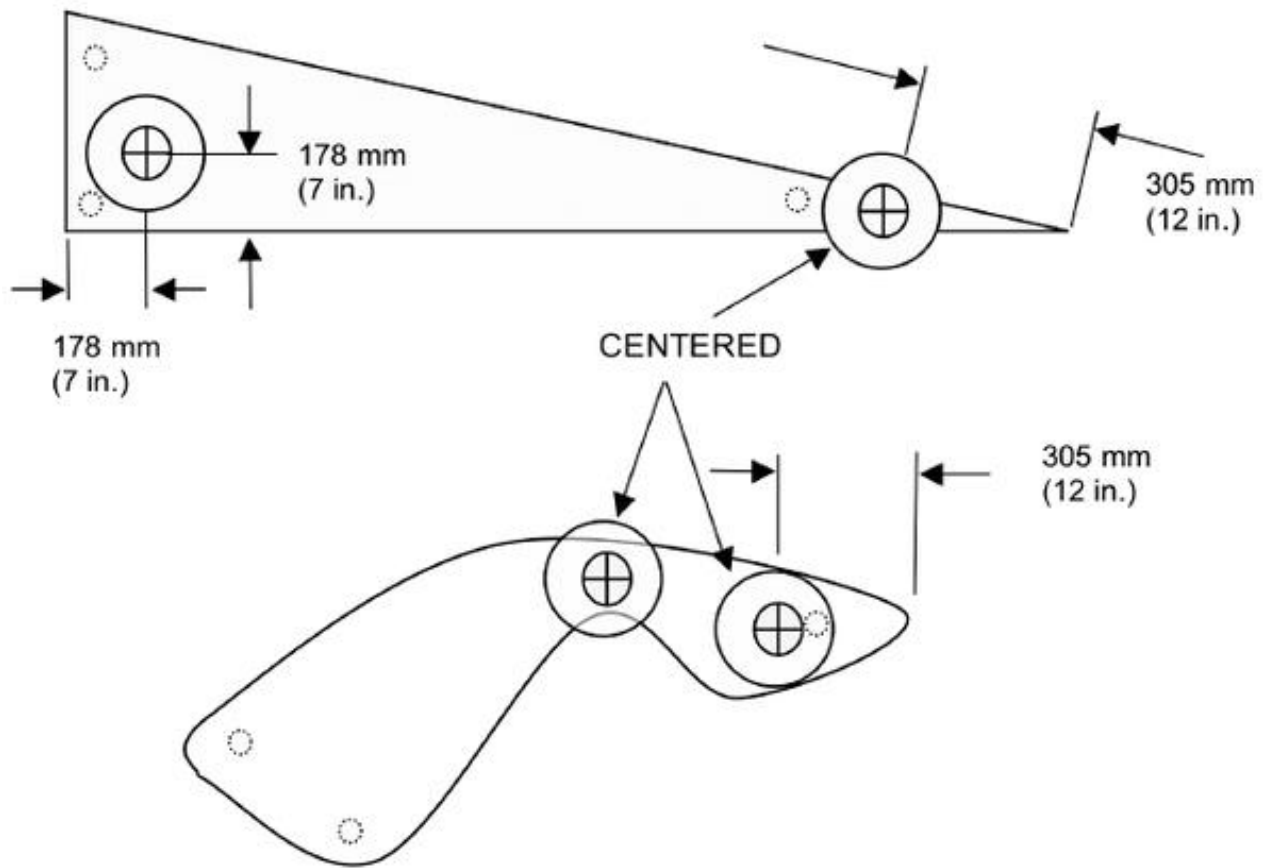

Figure 4c - Stability Loading for Irregular Shaped Tables

4 Stability Tests

4.1 Purpose of Tests

The purpose of these tests is to evaluate the stability of the desk/table product.

4.2 Stability with Extendible Elements Open Test (See figure 4a)

4.2.1 Test Setup

- a) The unit shall be placed on a test platform and leveled. If the unit is equipped with glides, extend them to their midpoint but not to exceed 13 mm (0.5 in.) from the fully retracted position. If equipped with casters, each front caster shall be blocked with an obstruction or other restraining device 13mm (0.5 in.) in height affixed to the test platform. The device shall prevent sliding but not restrict the unit from tipping. Casters shall be oriented in their least stable position.
- b) Determine the two extendible elements that, when loaded and opened, provide the least stable condition. (This may require evaluation of whether interlocked extendible elements can be opened if they are activated simultaneously.) Load these extendible elements with the functional load specified per Table 1 (See page 20). Load shall be configured per Section 3.9. If the unit does not allow two extendible elements to be opened simultaneously, only load the largest capacity extendible element. More than one loading configuration may be required to verify that the least stable condition has been evaluated.
- c) All remaining extendible elements and desk/table components shall be in the closed position, unlocked, and not loaded.

4.2.2 Test Procedure

Gradually open the loaded extendible element(s) to the fullest extension the unit will allow. (Open simultaneously if there are two extendible elements).

4.2.3 Acceptance Level

The unit shall not tip over. If open extendible elements prevent the unit from tipping over due to contact with the test platform, the unit does not meet the acceptance criteria.

Note:

The use of devices such as casters on a bottom extendible element is an acceptable method of preventing tipping.

4.3 Stability Under Vertical Load Test (See Figure 4b and 4c)

Note: This test applies to table/desks with or without extendible elements.

4.3.1 Test Setup

The unit shall be placed on a level platform and leveled in its normal operating position. Adjustable height desk/tables shall be positioned at a height that places the desk/table in its least stable condition.

4.3.2 Test Procedure

- a) Place a 305 mm (12 in.) diameter disk so that its center is 178 mm (7 in.) from the edge of the top at the least stable location. If the center of the disk is greater than 305 mm (12 in.) from a corner of the top, move the disk such that its center is 305 mm (12 in.) from the corner keeping the edges of the disk equidistant from both sides of the top. If, at the least stable position, the top has a depth less than 356 mm (14 in.), center the loading disk across the depth at that position. See Figure 4c.
- b) Place a 57 kg (125 lb.) static load on the disk.
- c) If necessary, repeat steps (a) and (b) to verify the least stable position has been evaluated.

4.3.3 Acceptance Level

The unit shall not tip over. If an extendible element(s) opens during the test and prevents the unit from tipping over due to contact with the test platform, the unit does not meet the acceptance criteria.

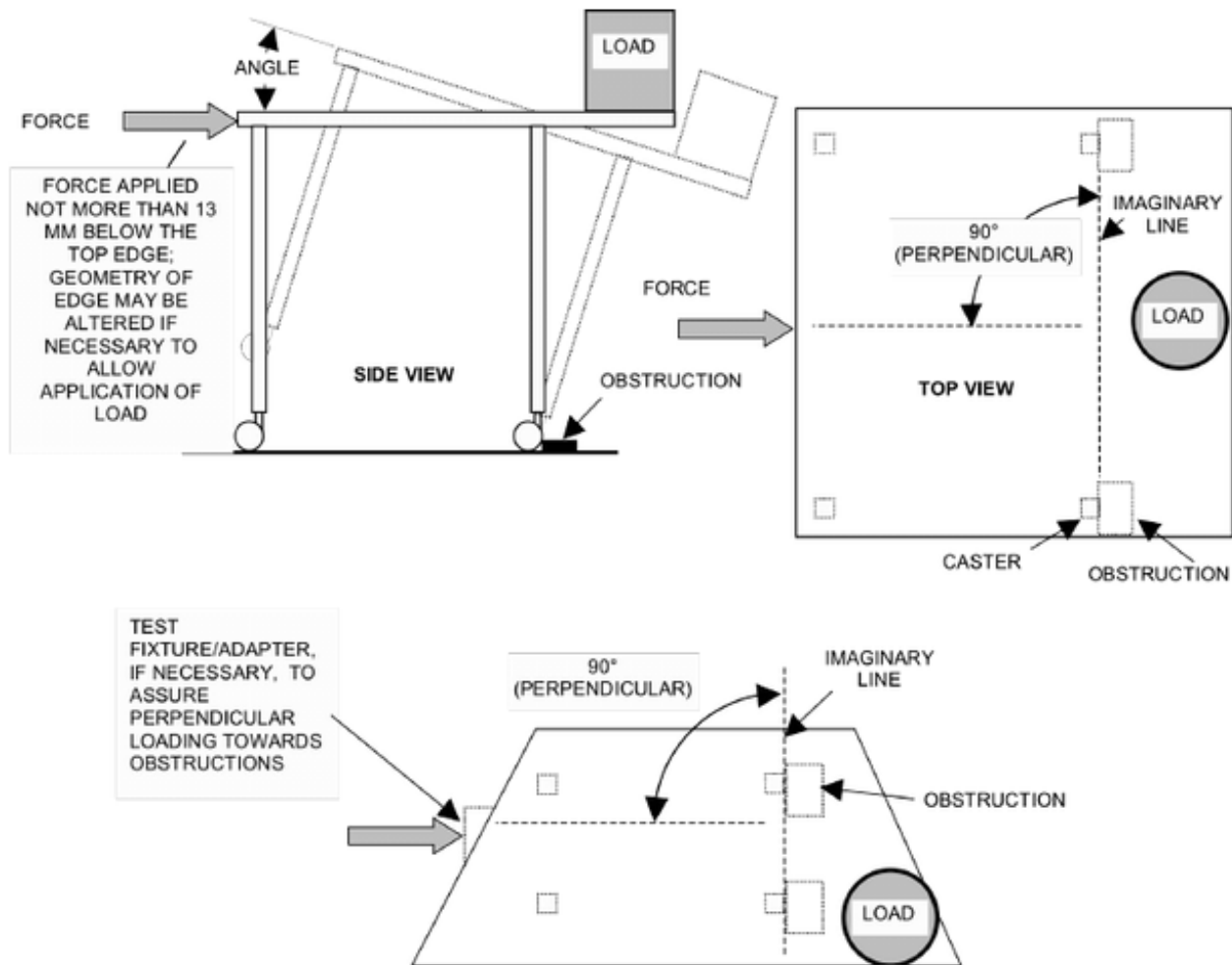

Figure 4d – Horizontal Stability Test for Desk/Tables with Casters

4.4 Horizontal Stability Test for Desk/Tables with Casters (See Figure 4d)

Note: this test applies to table/desks with or without extendible elements.

4.4.1 Test Setup

The unit shall be placed on a level platform and leveled. Adjustable height desk/tables shall be positioned at a height that places the desk/table in its least stable condition.

4.4.2 Test Procedure

- a) Apply a 11.4 kg (25 lb) static load through a 203 mm (8 in.) diameter disk centered 102 mm (4 in.) from the edge of the top of the desk/table at the least stable location.
- b) The casters that primarily support the load in (a) shall be blocked with an obstruction or other restraining device 13 mm (0.5 in.) in height affixed to the test platform. The device shall prevent sliding but not restrict the unit from tipping. Casters shall be oriented in their least stable position.

- c)** Gradually apply a horizontal force to the leading edge of the top surface, but not more than 13mm (0.5 in.) below the top surface directly opposite the load. If the geometry of the leading edge does not permit a direct application of the load, the geometry of the leading edge may be altered to accommodate the 13 mm (0.5 in.) dimension. The load shall be applied perpendicular to the line formed by the caster obstruction(s) in (b), until 44.5 N (10 lbf.) is reached, or the product tilts to 10 degrees minimum, whichever occurs first. The force applied shall remain horizontal throughout its application. (Angle measuring device must be accurate to within ± 0.5 degree.) A test fixture/adaptor shall be used if the edge of the top is not parallel to the line formed by the obstruction(s) in (b).
- d)** If necessary, repeat Steps (a) through (c) to verify the least stable position has been evaluated.

4.4.3 Acceptance Level

The unit shall not tip over. If an extendible element(s) opens during the test and prevents the unit from tipping over due to contact with the test platform, the unit does not meet the acceptance criteria.

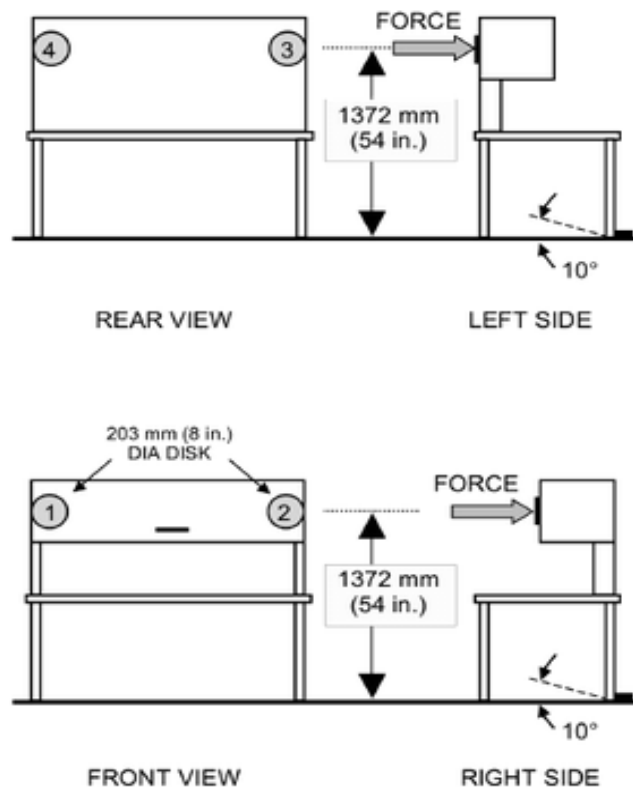

Figure 4e - Force Stability Test for Tall Desk/Table Products

4.5 Force Stability Test for Tall Desk/Table Products (See Figure 4e)

This test applies to any unit that is higher than or can be adjusted to heights greater than 1067 mm (42 in.). This test also applies to units with multiple segments that meets all of the following criteria:

the top segment is a screen that causes the unit to be greater than 1067 mm (42 in.) in height, the screen weighs more than 4.9 kg/m² (1 lb./ft².) of surface area (area calculated based on one side only) and the screen weighs more than 9 kg (20 lbs.).

4.5.1 Purpose of Test

The purpose of this test is to evaluate the stability of tall desk/table products.

4.5.2 Test Setup

The unloaded desk/table unit shall be placed on a test platform and leveled or positioned in accordance with manufacturer's instructions. If the unit is equipped with glides, extend them to their midpoint but not to exceed 13 mm (0.5 in.) from the fully retracted position. Glides, feet or casters

shall be blocked with an obstruction or other restraining device 13 mm (0.5 in.) in height affixed to the test platform. The device shall prevent sliding but not restrict the unit from tipping. Adjustable height desk/tables shall be positioned at a height that places the desk/table in its least stable condition.

Castors shall be oriented in their least stable position. Doors and/or extendible elements in the desk/table unit shall be closed and unlocked.

4.5.3 Test Procedure

- a) Apply the horizontal forces through the center of a disk that is 203 mm (8 in.) in diameter. If the geometry of the product inhibits the use of the 203 mm (8 in.) disk, apply the force through a smaller diameter disk.
- b) Gradually increase the force until 177 N (40 lbf.) is reached, or the product tilts to 10 degrees, whichever occurs first (angle measuring device must be accurate to within ± 0.5 degree) at the locations specified in step (c).
- c) The forces shall be applied one at a time to the following locations located 1372 mm (54 in.) from the floor or 102 mm (4 in.) down from the top edge, whichever is lower:
location 1: Apply force to front of the product at its left side,
location 2: Apply force to front of the product at its right side,
location 3: Apply force to back of the product at its left side,
location 4: Apply force to back of the product at its right side.
See Figure 4e for a description of the force locations.

4.5.4 Acceptance Level

The unit shall not tip over, and there shall be no loss of serviceability. Assembled desk/table product shall not disengage. If an extendible element(s) opens during the test and prevents the unit from tipping over due to contact with the test platform, the unit does not meet the acceptance criteria.

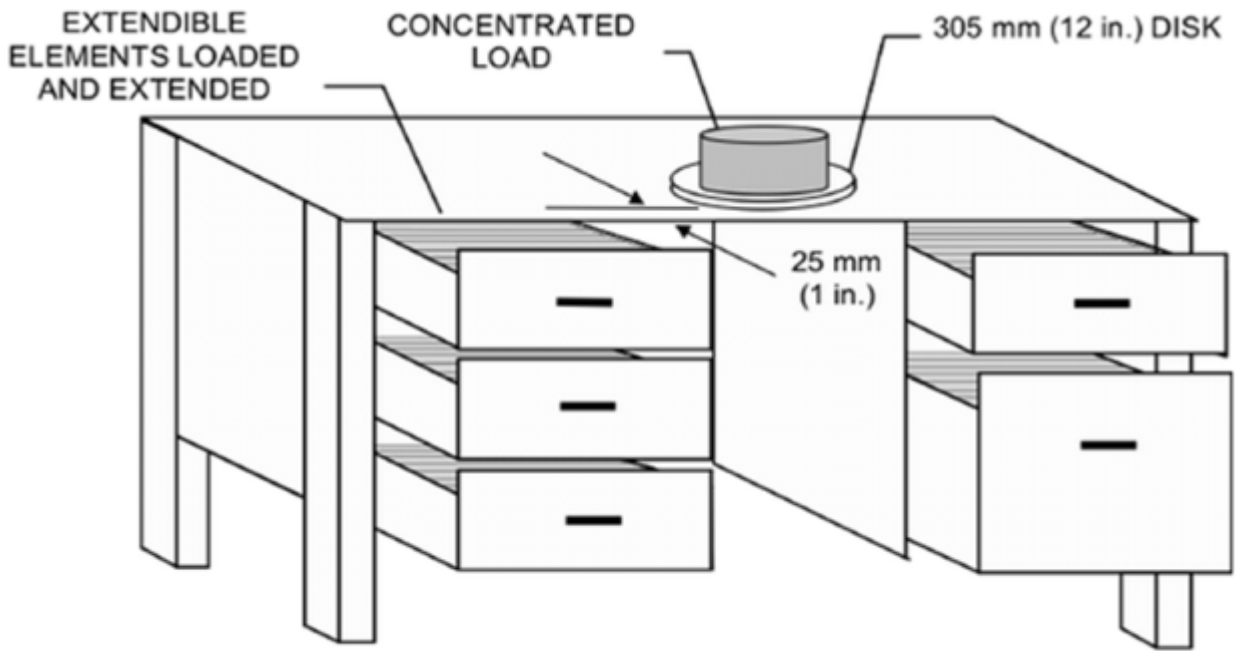

Figure 5a – Concentrated Load Test for Primary Surfaces

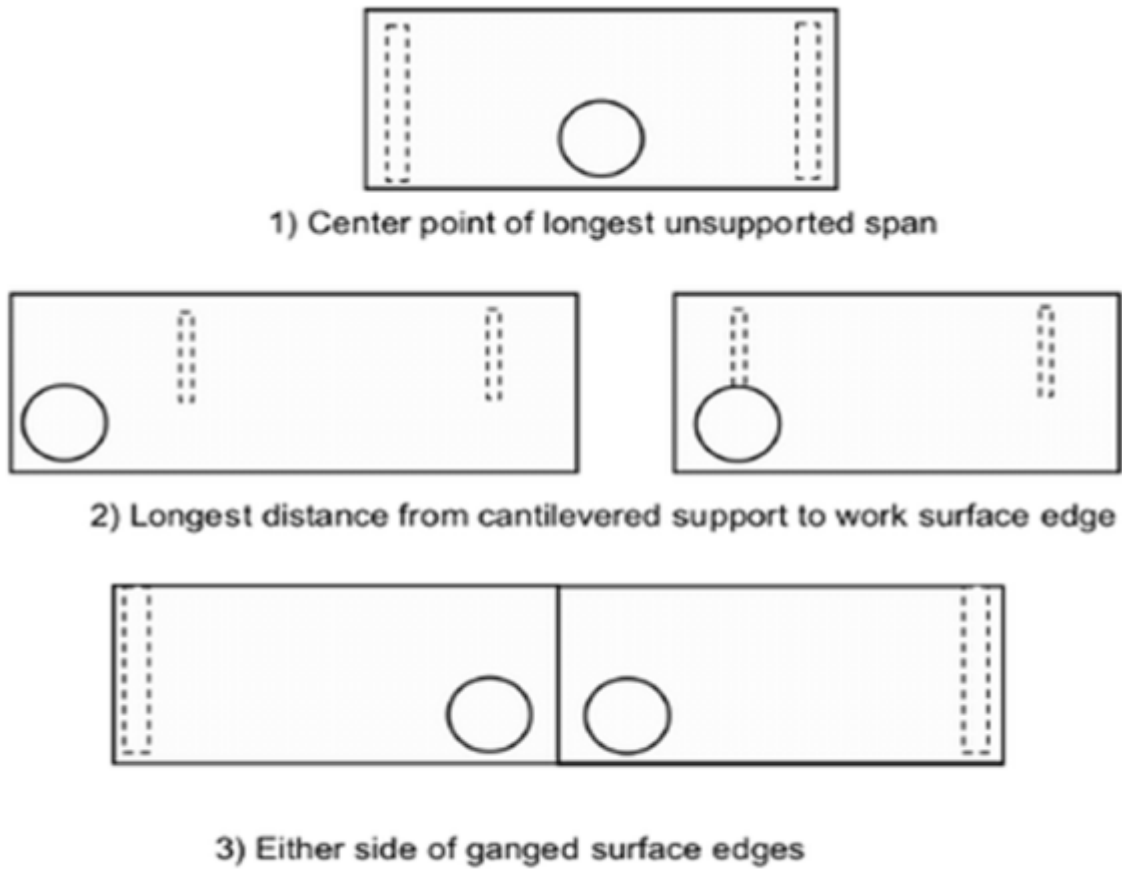

Figure 5b - Top View of Placement of Concentrated Load(s)

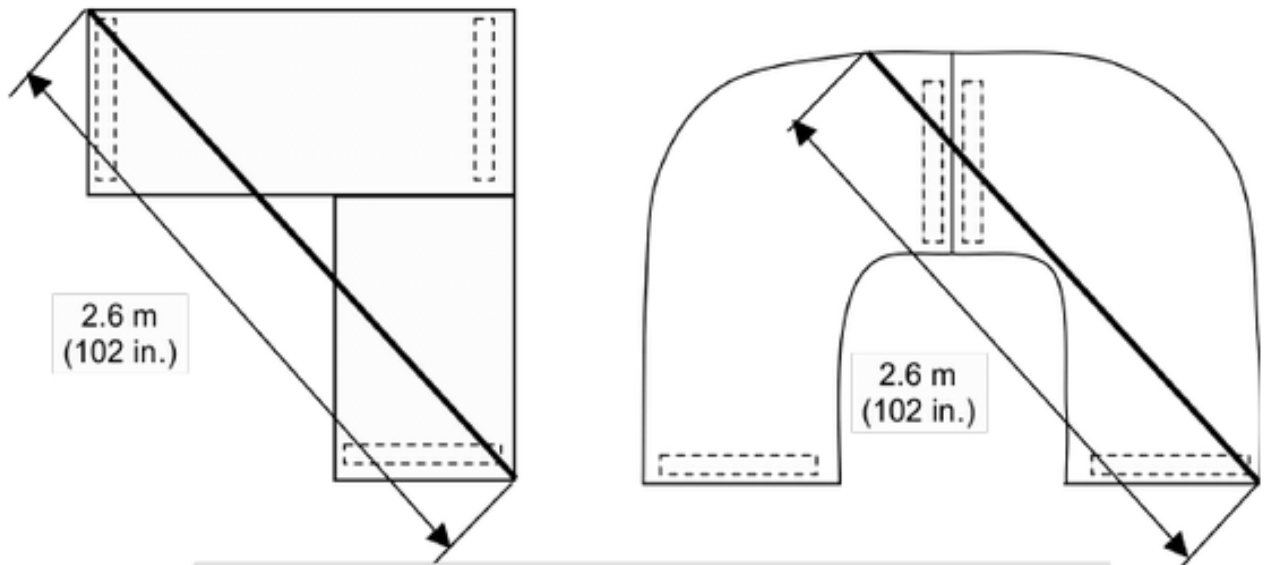

Figure 5c - Top View of Ganged Units Surface Size Determination

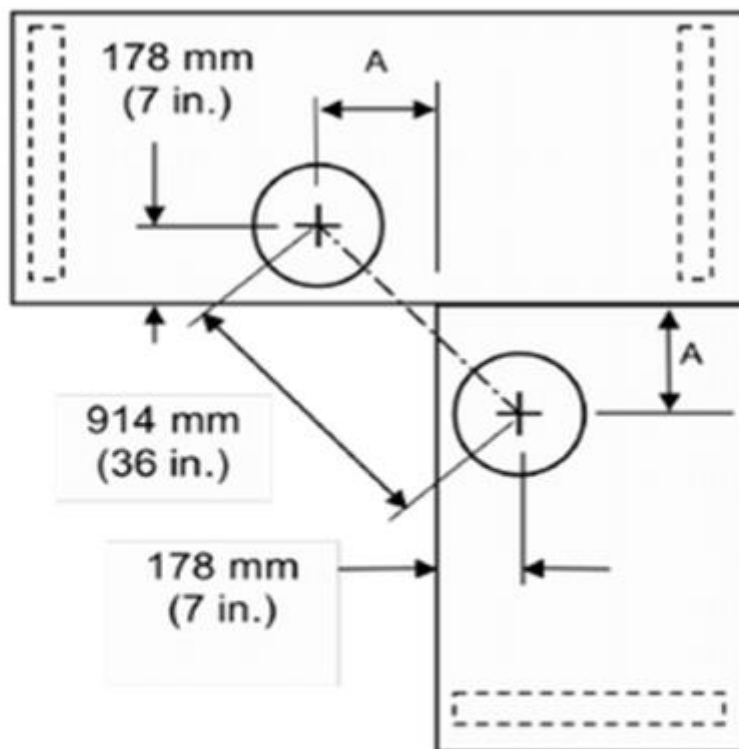

Figure 5d - Top View of Dual Concentrated Load Tests

5 Unit Strength Tests

Note: the following unit strength tests may be conducted in any order (concentrated vs. distributed loadings), however the functional loadings should be applied prior to the proof loadings.

5.1 Purpose of Tests

The purpose of these tests is to evaluate the ability of the unit to withstand static loads when loaded to its full capacity. Combined components shall be tested simultaneously as a unit (See definition 2.5.0).

For cabinets with doors that stow above the cabinet top, the top surface shall not be loaded during these tests.

5.2 Concentrated Functional Load Test (See Figures 5a-d and 4c)

5.2.1 Test Setup

- a) The unit shall be leveled and the base may be secured to the test platform to prevent tipping. The method of securing shall not affect the load application. If the unit requires support from adjacent units, all units shall be tested together as a system. Adjustable height tables shall be adjusted to their highest position but not to exceed 965 mm (38 in.).
- b) Apply the specified concentrated load to the primary surface per Table 1 (See page 20) through a 305 mm (12 in.) diameter disk so that its center is 178 mm (7 in.) from the unit's edge at its apparent weakest point. If the center of the disk is greater than 305 mm (12 in.) from a corner of the top, move the disk such that its center is 12 in. from the corner keeping the edges of the disk equidistant from both sides of the table top. If at the apparent weakest point the top has a depth less than 356 mm (14 in.), center the loading disk across the depth at that position (See Figure 4c). Ganged unit surfaces where ganging device(s) provide structural support to the unit shall be tested as a single surface. (Large ganged surfaces shall be tested in accordance with 5.2.1c). When the weakest point is not obvious, several load applications may be necessary to properly test the product.

The following are some typical weakest points(see Figure 5b):

- example 1) Center point of longest unsupported span.
- example 2) Longest distance from cantilevered support to work surface edge.
- example 3) Each side of ganged surface edges.

- c) When testing ganged units where the surface size is such that a 2.6 m (102 in.) chord cannot fit within the area of the tops (See Figure 5c), (See Step 5.2.1b (Example 3)), two concentrated loads are required. The concentrated loads, described in Table 1 (See page 20), are applied through 305 mm (12 in.) diameter disks. Place the two 305 mm (12 in.) diameter disks equidistant about the ganged edge while maintaining the centers of these disks $914 \text{ mm} \pm 25 \text{ mm}$ (36 in. \pm 1.0 in) apart and 178 mm (7 in.) in from the edge of the ganged unit's top (see Figure 5d).
- d) When testing units with lengths (or diameters) greater than 1829 mm (72 in.), two concentrated loads are required. The concentrated loads, described in Table 1 (See page 20), are applied through 305 mm (12 in.) diameter disks. The centers of these disks shall be placed $915 \text{ mm} \pm 25 \text{ mm}$ (36 in. \pm 1.0 in.) apart and 178 mm (7 in.) in from the edge of the unit's top at the apparent weakest point. See Section 5.2.1b for guidelines.
- e) All extendible elements shall be loaded according to the functional loads per Table 1 (See page 20) and fully opened for the duration of the test. If the unit contains an interlock that will not allow all extendible elements to be open simultaneously, open the largest capacity extendible element(s).

5.2.2 Test Procedure

- a) Loads shall be allowed to remain for 60 minutes and then removed
b) Perform the Pull Force Test in Section 19.

5.2.3 Acceptance Level

There shall be no loss of serviceability. Upon completion of the test, the extendible member(s) shall meet the pull force requirements of Section 19.

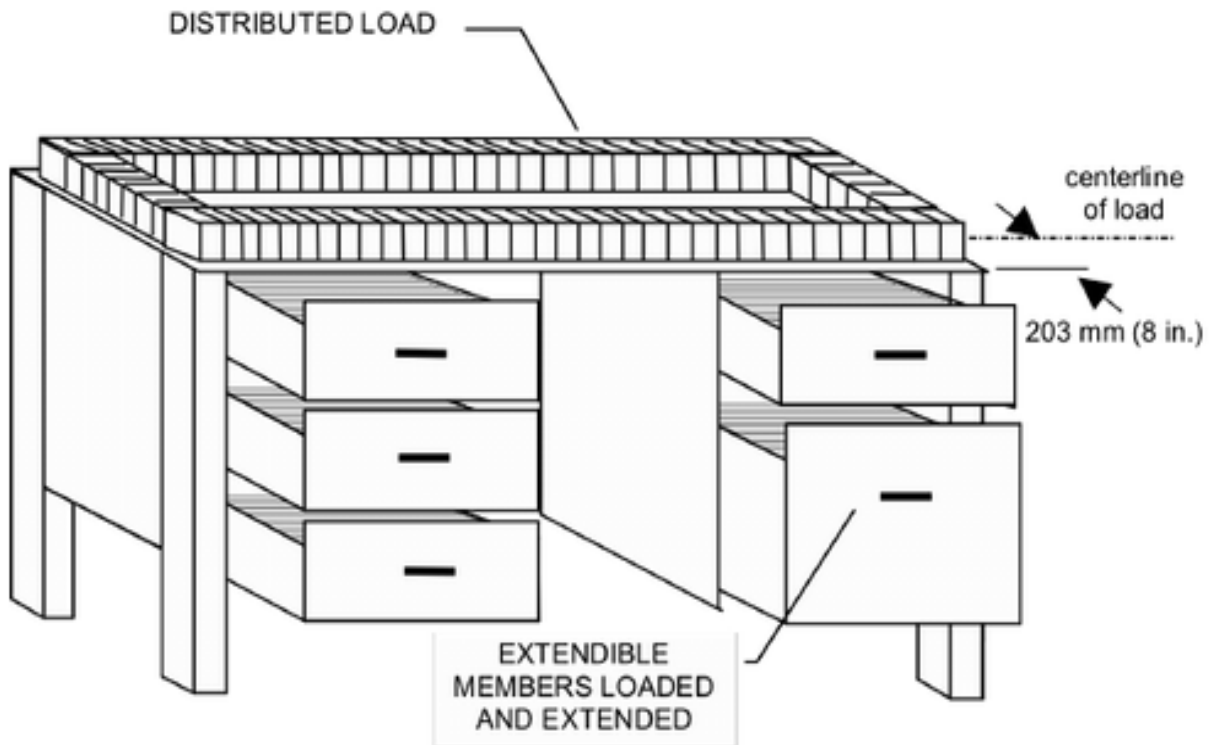

Figure 5e - Distributed Load Tests for Primary Surfaces

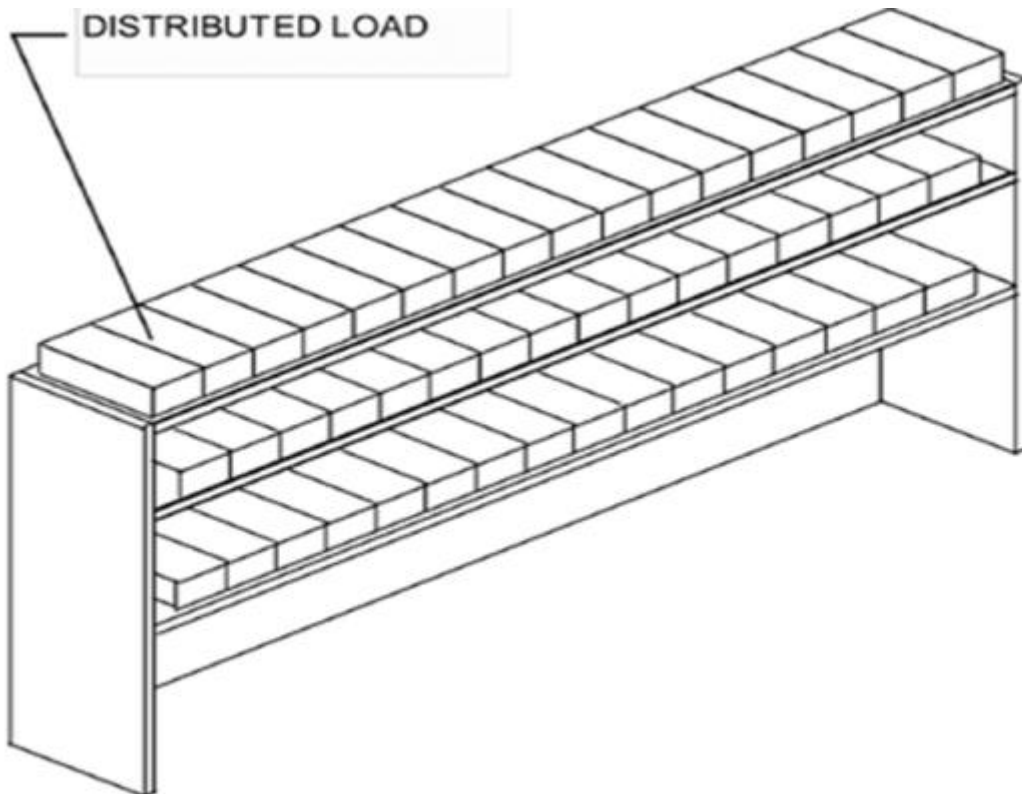

Figure 5f - Distributed Load Tests for Secondary Surfaces

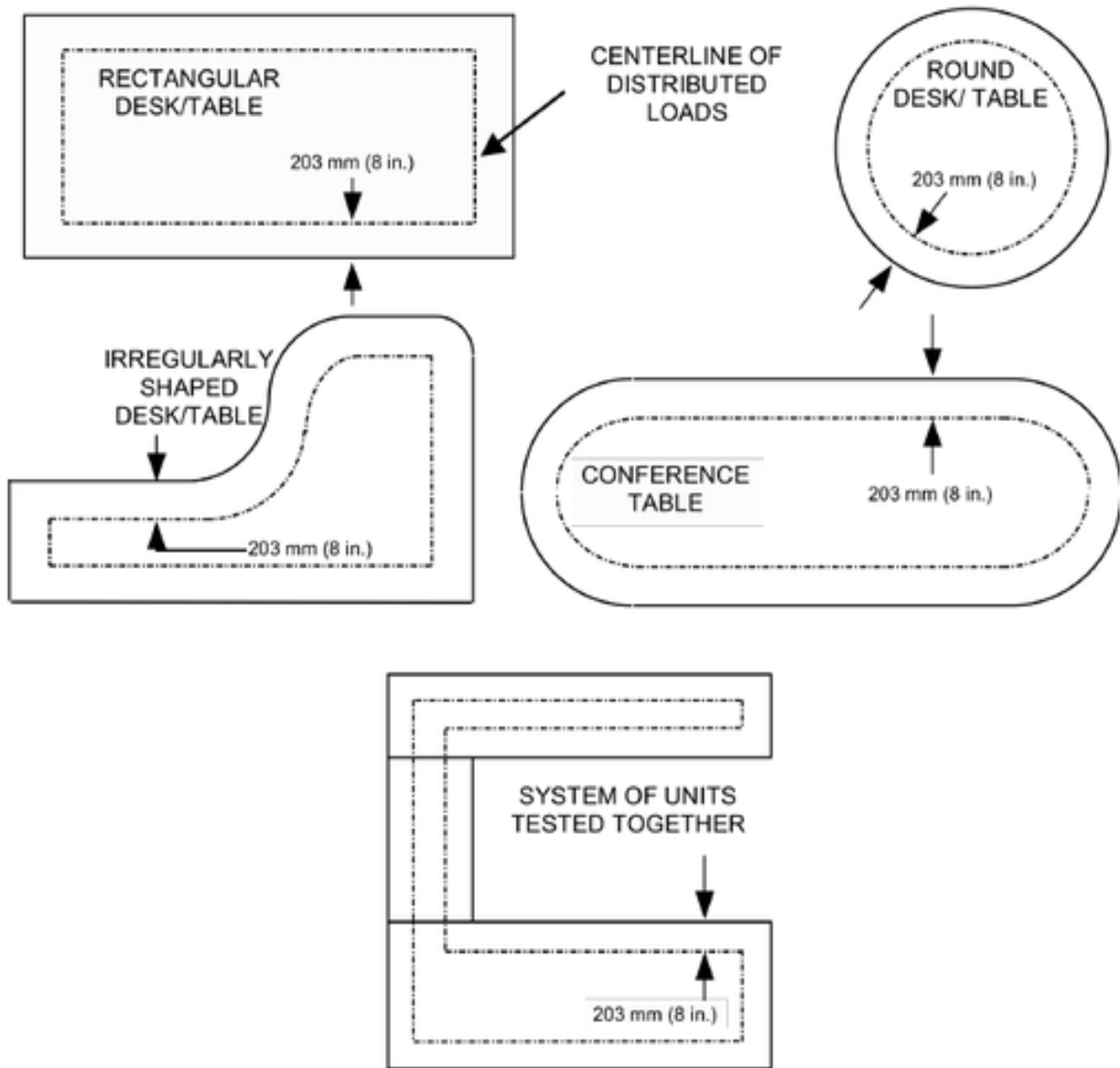

Figure 5g - Top View of Distributed Load Tests for Primary Surfaces

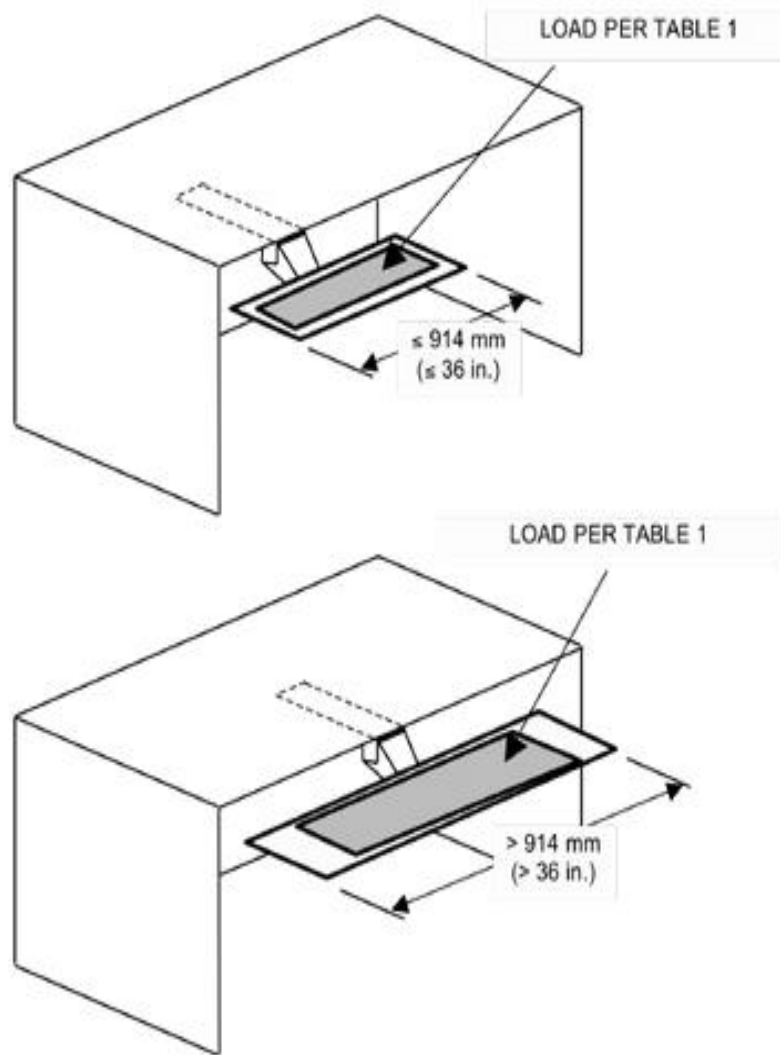

Figure 5h - Distributed Load Tests for Adjustable Keyboard Supports

5.3 Distributed Functional Load Test (See Figures 5e through 5h)

5.3.1 Test Setup

- a) The unit shall be leveled and the base may be secured to the test platform to prevent tipping.
The method of securing shall not affect the load application. If the unit requires support from adjacent units, all units shall be tested together as a system. Adjustable height tables shall be adjusted to their highest position. Keyboard support surfaces shall be loaded in their worst-case position.
- b) Depending on the desk/table surface classification, apply the specified distributed loads per Table 1 (See page 20). For primary surfaces, loads shall be evenly distributed and centered over a line 203mm (8 in.) in from the edge along the entire perimeter. For surfaces that are less than 406 mm (16 in.) deep, evenly distribute the load across the surface. The loads may be secured to the surface if necessary to perform this test.
- c) All extendible elements shall be loaded per Table 1 (See page 20) and fully opened for the duration of the test. If the unit contains an interlock that will not allow all extendible elements to be open simultaneously, open the largest capacity extendible element(s).

5.3.2 Test Procedure

- a) Loads shall be allowed to remain for 60 minutes and then removed.
- b) Close the extendible elements and perform the Pull Force Test in Section 19.

5.3.3 Acceptance Level

There shall be no loss of serviceability. Upon the completion of the test, the extendible member(s) shall meet the pull force requirements of Section 19.

5.4 Concentrated Proof Load Test (See Figures 5a-d and 4c)

5.4.1 Test Setup

The setup shall be performed per Section 5.2.1 with the appropriate concentrated proof load per Table 1 (See page 20), except for the extendible elements, which shall remain loaded with the functional loads.

5.4.2 Test Procedure

Loads shall be allowed to remain for 15 minutes and then removed.

5.4.3 Acceptance Level

There shall be no sudden and major change in the structural integrity of the product. Loss of serviceability is acceptable.

5.5 Distributed Proof Load Test (See Figures 5e-h)

5.5.1 Test Setup

Perform the setup per Section 5.3.1 using the appropriate distributed proof loads per Table 1, (See page 20) except for the extendible elements, which shall remain loaded with the functional loads.

5.5.2 Test Procedure

Loads shall be allowed to remain for 15 minutes and then removed.

5.5.3 Acceptance Level

There shall be no sudden and major change in the structural integrity of the product. Loss of serviceability is acceptable.

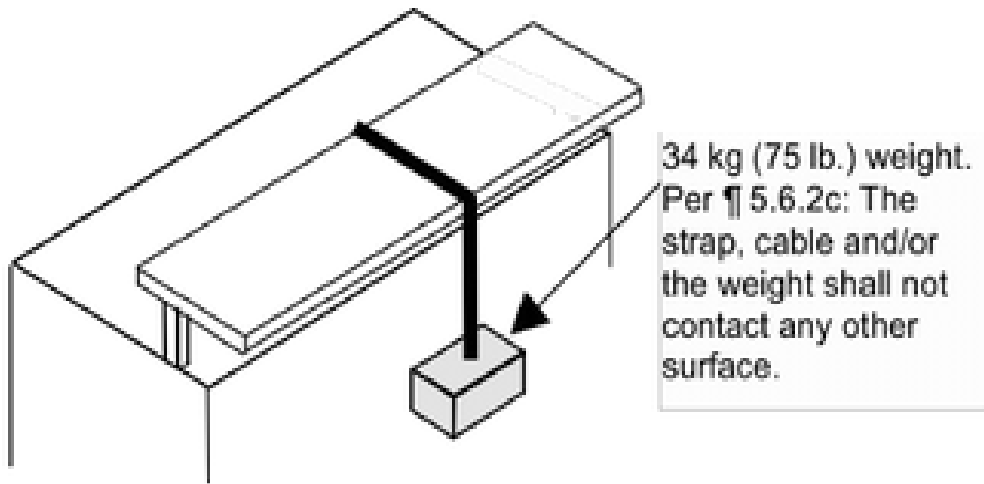

Figure 5i - Transaction Surface Torsion Load Test

5.6 Transaction Surface Torsion Load Test (see Figure 5i)

5.6.1 Purpose of Test

The purpose of this test is to evaluate the ability of the transaction surface to withstand torsional static loads which they may be subjected to when in use. If it is not clear if a surface is secondary or transaction, this test applies.

5.6.2 Test Setup

- a) The unit shall be leveled and the base may be secured to the test platform to prevent tipping. The method of securing shall not affect the load application.
- b) Attach a strap or stranded metallic cable to one edge of the transaction surface at its apparent weakest point.
- c) Pass the strap or stranded metallic cable over the top of the transaction surface and allow it to hang vertically below the opposite edge. The strap, cable and/or the weight shall not contact any other surfaces.
- d) Attach a 34 kg (75 lb.) weight to the free end of the strap or cable.

5.6.3 Test Procedure

- a) Allow the suspended weight to remain in place for 15 minutes.
- b) Remove the weight.
- c) If the transaction surface and/or its support are not symmetrical, repeat the test with the weight suspended from the opposite edge.

5.6.4 Acceptance Level

There shall be no loss of serviceability.

5.7 Extendible Element Static Load Tests

5.7.1 Purpose of Tests

The purpose of these tests is to ensure that the extendible element (including suspension system, interlock, in-stop/anti rebound, detent mechanisms, etc.) is durable and/or capable of supporting typical loads.

5.7.2 Extendible Element Functional Load Test

The functional loading tests for extendible elements are performed as described in Section 5.2 and 5.3 and need not be repeated if they have already been performed.

5.7.3 Extendible Element Proof Load Test

This test does not apply to pencil/center drawers.

5.7.3.1 a) The unit shall be leveled and the base may be secured to the test platform to prevent tipping.
The method of securing shall not affect the load application.

b) Determine the extendible element of each type (each element construction, suspension design, etc.) with the largest available clear space (if two or more elements have identical clear space, select one of the elements for further testing). Uniformly distribute a proof load per Table 1 (See page 20) in the selected extendible element.

5.7.3.2 Test Procedure

- a) Close the extendible element and allow the load to remain for 15 minutes.
- b) Open the extendible element, allow the load to remain for 15 minutes, and then remove the load.
- c) Repeat the test as necessary for each element per Section 3.1.4.

5.7.3.3 Acceptance Level

There shall be no sudden and major change in the structural integrity of the product. Loss of serviceability is acceptable.

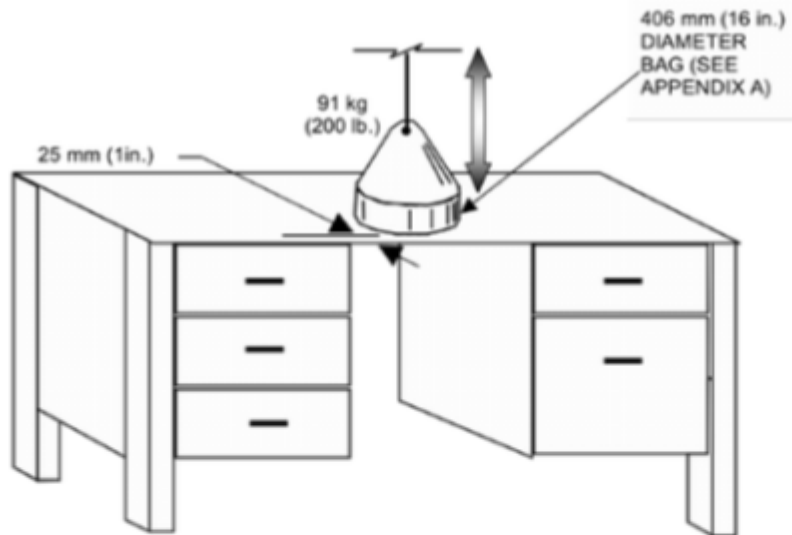

Figure 6 - Top Load Ease Cycle Test

6 Top Load Ease Cycle Test (See Figure 6)

6.1 Purpose of Test

The purpose of this test is to evaluate the durability of the unit to withstand cyclic loading of the primary surface(s) resulting from a person sitting on the unit. This test does not apply to:

- surfaces greater than 965 mm (38 in.) in height, or height adjustable units that cannot be adjusted to 965 mm (38 in.) or below.
- shelves or adjustable keyboard surfaces. (If it is unclear whether the surface is a primary or a shelf, this test applies.)
- units with integral (non detachable) overhead storage units, hutches, etc. that limit the useable depth of the primary surface to less than 406 mm (16 in.) or with designs that interfere with a person's ability to sit on the surface.

6.2 Test Setup

- a) The unit shall be placed on the test platform, leveled, and restrained to prevent movement. Units with tops that are height adjustable shall be tested at the midpoint of adjustment but not higher than 965 mm(38 in.).
- b) All extendible elements shall be loaded with the functional load per Table 1 (See page 20) and then closed for the duration of the test.
- c) For units with a primary surface with a depth greater than or equal to 457 mm (18 in.) deep, a 91 kg (200 lb.) weight applied by means of a 406 mm \pm 51 mm (16 in. \pm 2 in.) diameter bag (See Appendix A) shall be positioned with the edge of the bag within 25 mm (1 in.) from the edge of the surface at the center of the largest unsupported span. For primary surfaces with a depth less than 457 mm (18 in.), center the bag on the available surface depth.
- d) The cycling device shall be set to operate at a rate of 14 \pm 6 cycles per minute.

6.3. Test Procedure

- a) Prior to performing the test procedure, all extendible elements shall be tested to and meet the pull force requirements of Section 19.
- b) The bag shall be raised until the entire weight is off the primary surface and then eased (without impact) onto the primary surface, so that it takes the entire weight without any support from the cycling device.
- c) Repeat Step (a) for a total of 10,000 cycles.
- d) Remove the bag and perform the pull force test in Section 19.

6.4. Acceptance Level

There shall be no loss of serviceability to the unit. Before and after the cycling test, the extendible elements shall meet the pull force test requirements in Section 19.

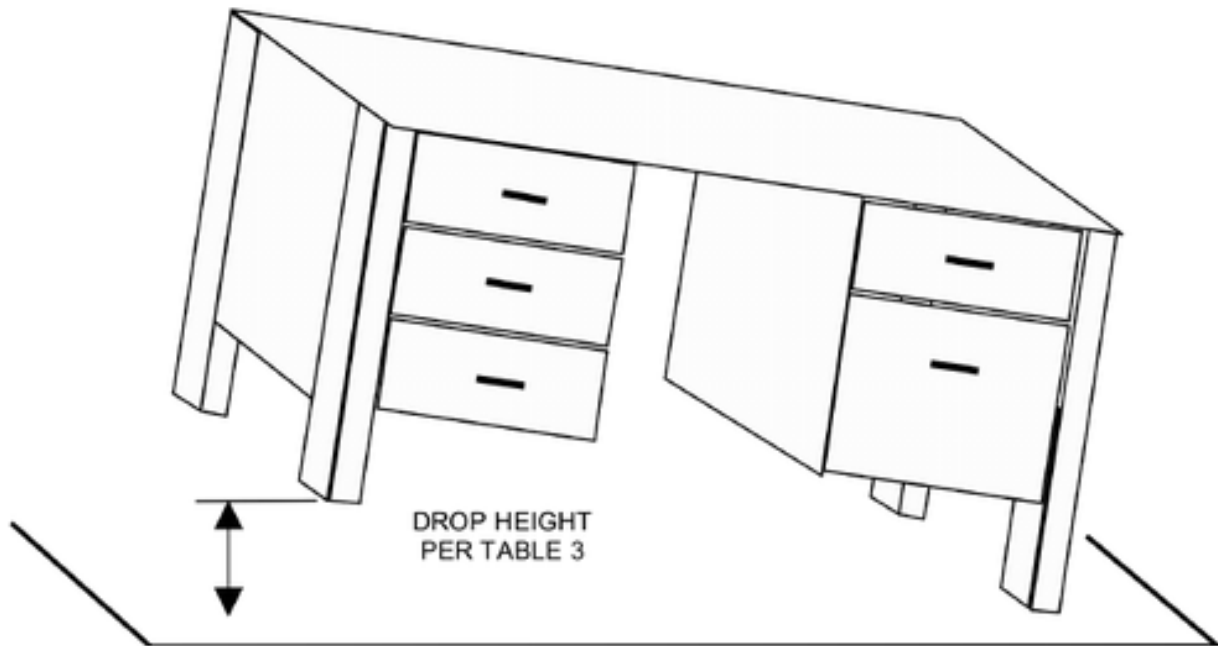

Figure 7 - Desk/Table Unit Drop Test

Table 3
Drop Height for Desk/Table Units

Unit Weight	Drop Height
<68 kg (150 lb.)	180 mm (7.1 in.)
≥68 kg (150 lb.)	120 mm (4.7 in.)

7. Desk/Table Unit Drop Test (See Figure 7)

This test applies to ungangled freestanding Category I desks or tables products which are less than or equal to 1829 mm (72 in.) in length. This test does not apply to desk/table units with casters.

7.1 Purpose of Test

The purpose of this test is to determine the ability of a desk/table unit to withstand an impact force on the legs, column or base.

7.2 Test setup

On desk/table units with adjustable features, set the adjustable features at the midpoint of adjustment.

7.3 Test procedure

- a) Prior to performing the test procedure, all extendible elements shall be tested to and meet the pull force requirements of Section 19.
- b) Determine the weight of the unloaded desk/table unit to be tested.
- c) The unit shall be placed on a test platform and leveled. If the desk/table unit is equipped with glides, extend them to their midpoint but not to exceed 13 mm (0.5 in.) from the fully retracted position.
- d) Raise one end of the long axis of the unloaded unit so that the bottom of the base is above the test platform at the height given in Table 3 (See page 43) or at the balance point, whichever is lower.
- e) The end of the unit being tested shall be released and allowed a free fall to the test platform.
- f) Repeat steps (d) and (e) for the other end of the desk/table unit.
- g) Perform the pull force test in Section 19 on all extendible elements.

7.4 Acceptance Level

There shall be no loss of serviceability. Before and after the drop test, the extendible elements shall meet the pull force test requirements in Section 19.

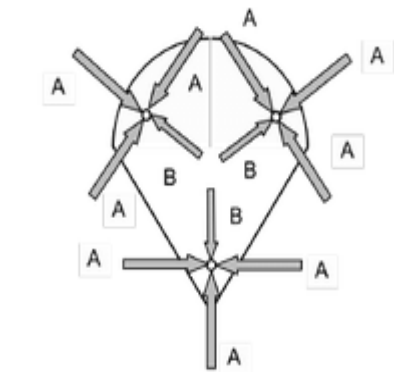
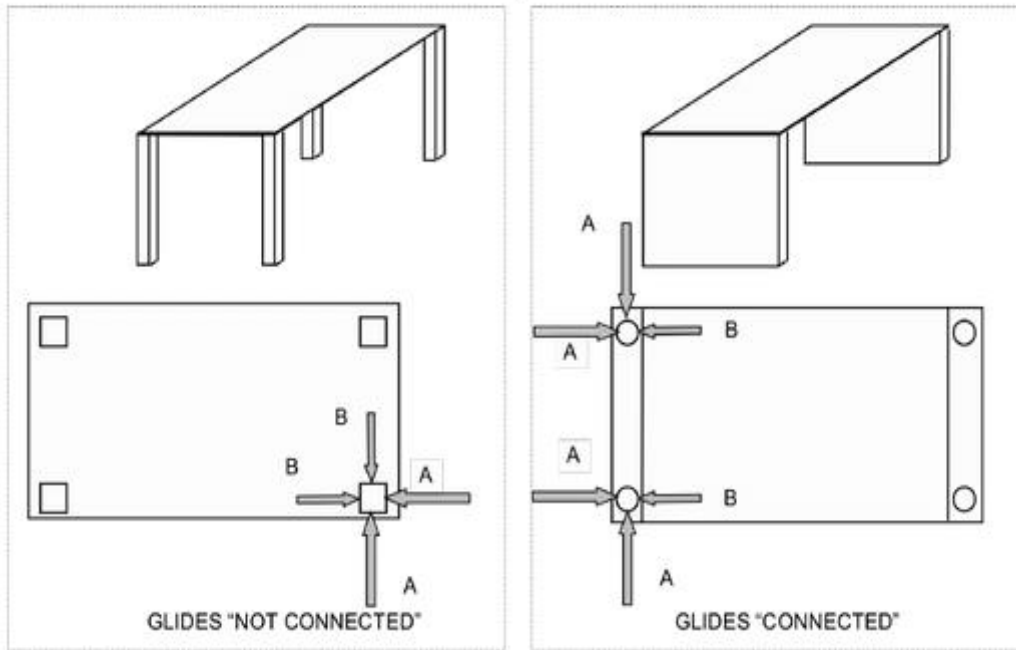

TABLES WITH "SPIDER" LEGS TESTED AS IF GLIDES ARE "NOT CONNECTED"

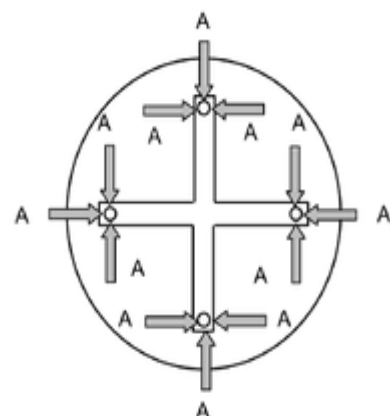

CROSS SLAB LEGS TESTED AS SHOWN ABOVE

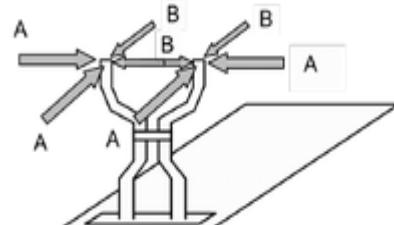

GLIDES "NOT CONNECTED"

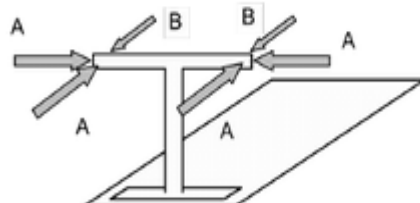

T-LEGS TESTED AS SHOWN

Figure 8 - Leg Strength Test – Typical Configurations

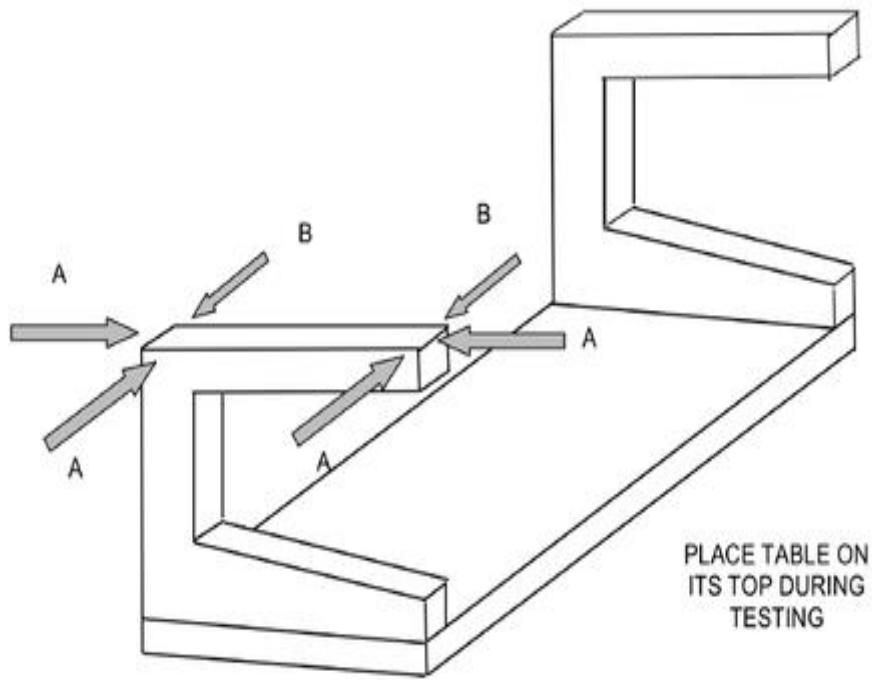

C-LEG TABLES TESTED AS SHOWN ABOVE

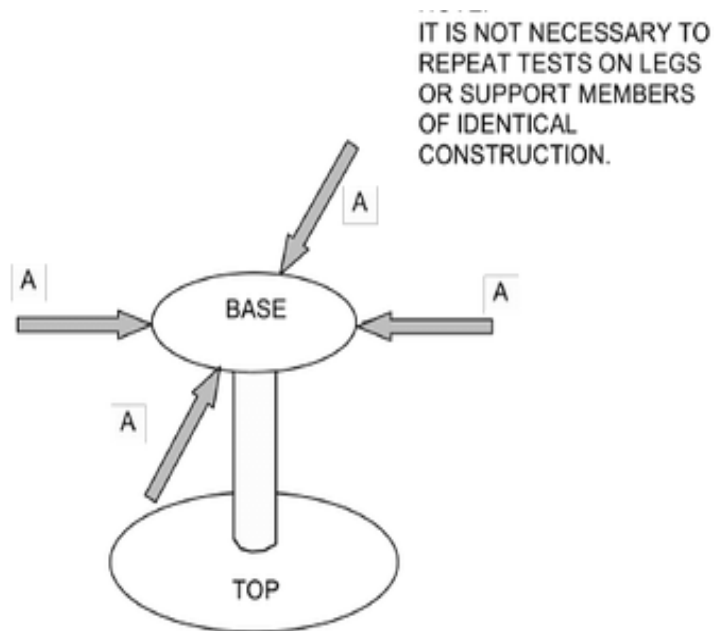

COLUMN TABLES TESTED AS SHOWN ABOVE

Figure 8 Continued - Leg Strength Test – Typical Configurations

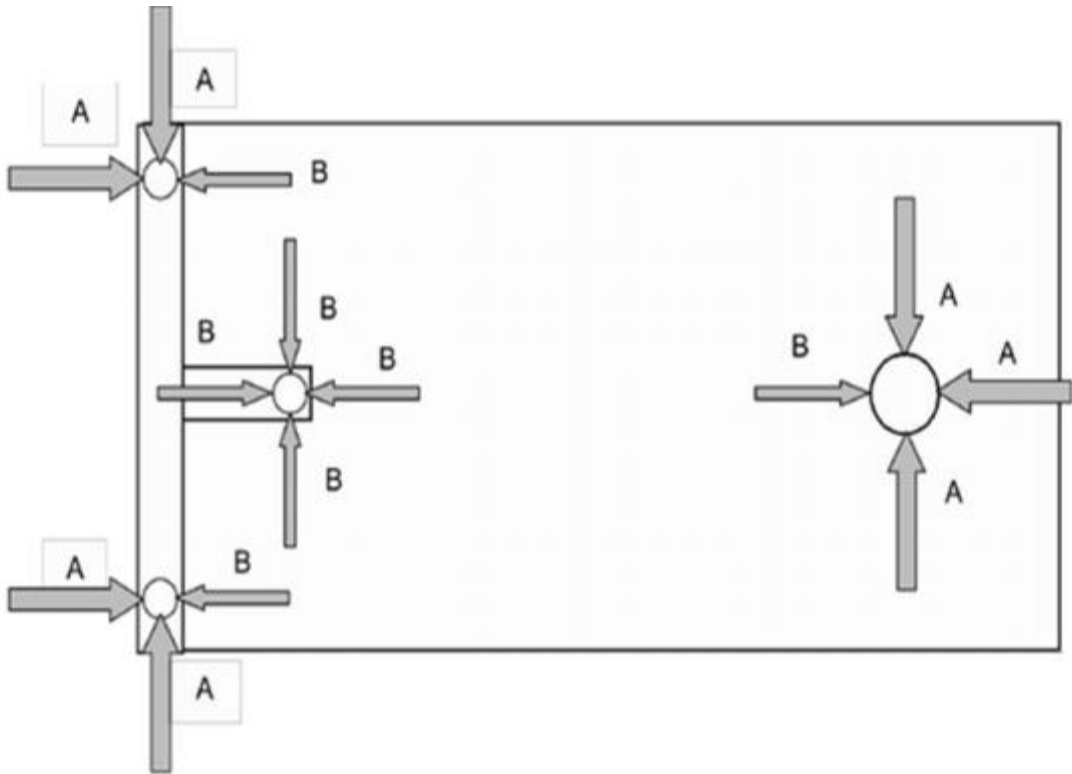

Figure 8 Continued - Leg Strength Test – Typical Configurations

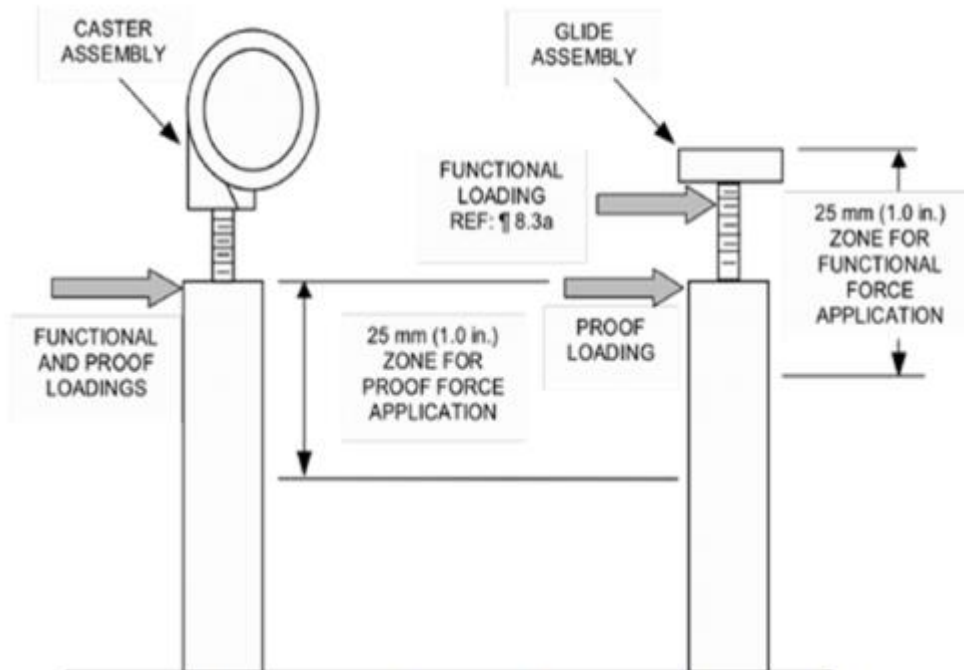

Figure 8 Continued - Leg Strength Test – Typical Load Application

8 Leg Strength Test (See Figure 8)

All tests must be performed on a single leg structure. It is not necessary to repeat tests on legs or support elements of identical construction. See Test Force Application 3.9.6.

8.1 Purpose of Test

The purpose of this test is to evaluate the ability of desk/table product to withstand handling or moving.

8.2 Test Setup

- a) The unloaded unit shall be positioned on its top, on a test platform, and secured in place. If the unit has glides, they shall be set at the midpoint of their adjustment range but not greater than 13 mm (0.5 in.). Adjustable height desk/tables shall be positioned at the midpoint of their adjustment range.
- b) Based on the desk or table Category, calculate the Functional Force "A" as follows (not to exceed 445 N (100 lbf.)):

Category I: "A" = 0.5 x (unit weight, kg) x 9.8 + 222 N
 ["A" = 0.5 x (unit weight, lb.) + 50 lbf.

Note: See Section 2.5 for definitions of categories.

- c) Calculate the Functional Force "B" as (0.5 x "A").
- d) Calculate the Proof Forces "A" (not to exceed 668 N (150 lbf.)) and "B" as follows:

Proof Force "A" = 1.5 x (Functional Force "A").
 Proof Force "B" = 1.5 x (Functional Force "B").

8.3 Functional Test Procedure

- a) Attach a loading device to the support member to be loaded. The placement of the loading device shall be within 25 mm (1 in.) of the end of the support member/glide assembly that makes contact with the floor. The placement of the loading device shall be as close to the glide end as possible (may be on the glide stem, but not on the glide foot itself). For tables with casters, apply the load as close as possible to the end of the support member but not to the caster assembly.
- b) Individually and separately apply the functional horizontal forces ("A" and "B") as described in Figure 8.

- c) Repeat steps (a) and (b) for each unique type or non-symmetrically placed supporting member on the desk/table product.
- d) If the leg being tested is attached to a desk pedestal, perform the pull force test per Section 19 on each type and size of extendible element in the attached desk pedestal.

8.4 Functional Test Acceptance Level

No loss of serviceability shall occur as a result of the application of the functional loads. After application of the functional loads, each extendible element in a leg-attached desk pedestal shall be tested to and meet the pull force requirements of Section 19.

8.5 Proof Test Procedure

- a) Attach a loading device to the support member to be loaded. The placement of the loading device shall be within 25 mm (1 in.) of the end of the support member. The load shall not be applied to the glide assembly (including stem, glide foot, etc.) or caster assembly.
- b) Individually and separately apply the horizontal proof forces ("A" and "B") as described in Figure 8.
- c) Repeat steps (a) and (b) for each unique type or non-symmetrically placed supporting member on the desk/table product.

8.6 Proof Test Acceptance Levels

Application of the proof loads shall cause no sudden and major change in the structural integrity of the product. Loss of serviceability is acceptable.

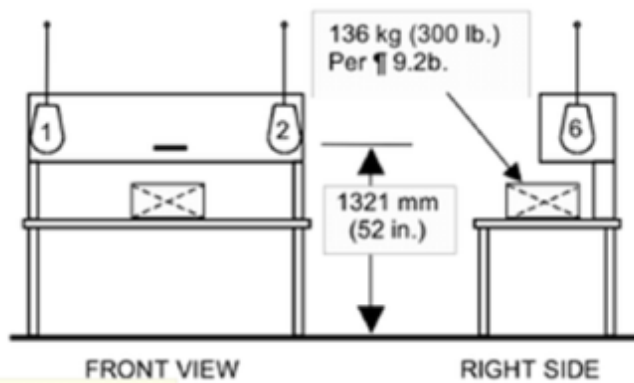
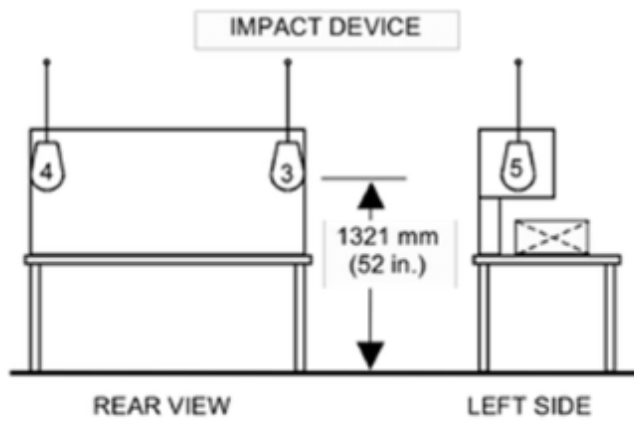
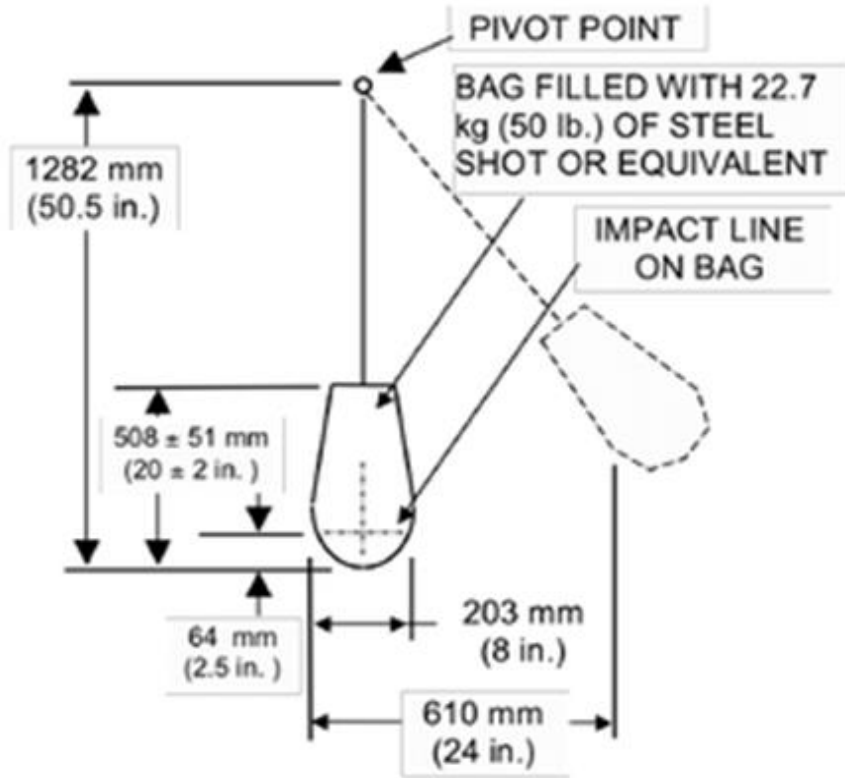

Figure 9 - Disengagement Tests for Tall Desk/Table Products

9 Disengagement Tests for Tall Desk/Table Products (See Figure 9)

This test applies to any units that are higher than 1067 mm (42 in.) tall. This test does not apply to adjustable height desk/tables that can be adjusted above 1067 mm (42 in.).

9.1 Purpose of Test

The purpose of this test is to evaluate the ability of tall desk/table product components to resist disengagement. This test also applies to unit mounted screens or screen assemblies with weight of more than 4.9 kg/m² (1 lb./ft².) of surface area (area calculated based on one side only) and total weight exceeding 9 kg (20 lbs.).

If the manufacturer's instructions indicate that the unit must be placed against the wall, no back or front horizontal disengagement tests are required.

9.2 Test Setup

- a) The unit shall be placed on a test platform and leveled.
- b) Place a 136 kg. (300 lb.) load in the center of the primary surface of the desk/table unit to prevent the unit from tipping during the test.
- c) The other elements in the unit shall not be loaded.

9.3 Test Procedure

- a) Swing a bag that is 203 mm (8 in.) in diameter, weighing 22 kg (50 lb.) and suspended on a cable, through a horizontal distance of 609 mm (24 in.). See Figure 9 for a description of the bag impact device.
- b) Impact the unit once each at the following locations centered along a line that is 1321 mm (52 in.) from the floor or 102 mm (4 in.) down from the top edge, whichever is lower:
 - location 1: Impact front of product at its left side,
 - location 2: Impact front of product at its right side,
 - location 3: Impact back of product at its left side,
 - location 4: Impact back of product at its right side,
 - location 5: Impact center of product's left side,
 - location 6: Impact center of product's right side.

See Figure 9 for a description of the impact locations.

9.4 Acceptance Level

The tested unit or its components shall not become disengaged from the desk/table unit.

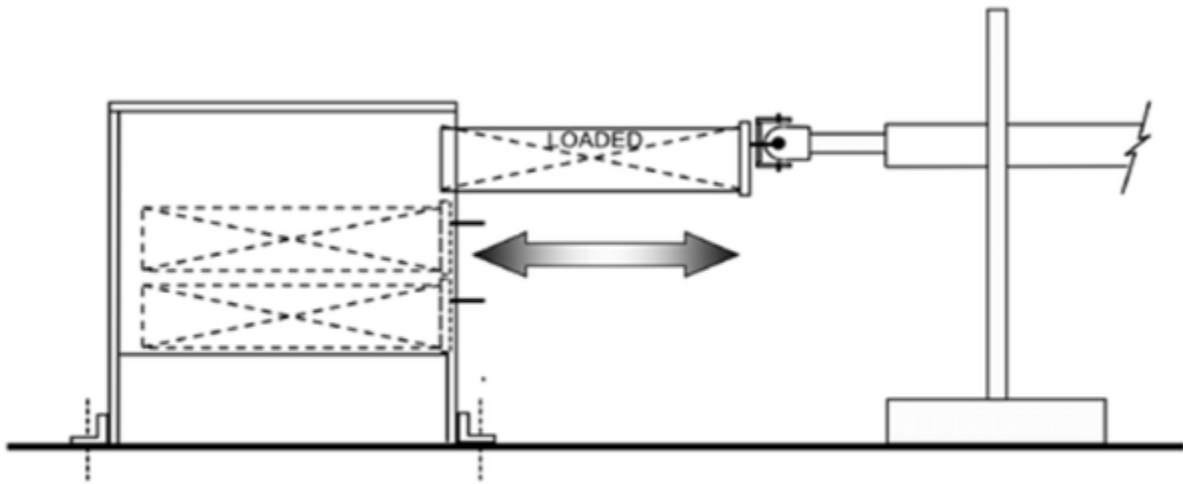

Figure 10 - Extensible Element Cycle Test

10 Extendible Element Cycle Test (See Figure 10)**10.1 Purpose of Tests**

The purpose of these tests is to ensure that the extendible element (including suspension system, interlock, in-stop/anti rebound, detent mechanism, etc.) is durable and capable of supporting typical loads while it is being opened and closed.

10.2 Cycle Test for Extendible Elements Deeper Than Wide

Note: Center/Pencil Drawers are tested per Section 10.4

- 10.2.1**
- a) The unit shall be placed on a test platform, leveled, and secured against movement. Prior to performing test procedure, the extendible element, if equipped with an interlock device, shall meet the interlock test requirements of Section 13.
 - b) The extendible element being tested shall be uniformly loaded to the functional load per Table 1 (See page 20). Load shall be configured per Section 3.9.
 - c) The cycling device shall be connected to the center of the extendible element's pull. If equipped with side pulls, the cycling device shall be connected to the center of either pull.
 - d) The cycling device shall be set to cause the extendible element to travel within 0 to 6 mm (0 to 0.25 in.) of the closed position to 0 to 6 mm (0 to 0.25 in.) of the fully extended position and return. This amount of travel shall constitute one cycle. The cycling device shall not support or add vertical or horizontal loads to the suspensions.
 - e) The cycling device shall be operated at a rate of 12 ± 4 cycles per minute.

10.2.2 Test Procedure

- a) Prior to performing test procedure, the extendible element shall be tested to and meet the pull force requirements of Section 19.
- b) The extendible element shall be subjected to 50,000 cycles per 10.2.1(d) and (e).
- c) The suspensions shall not be cleaned or lubricated during the test.

Note:

When necessary to compensate for ball-bearing cage creep the extendible element should be reset throughout the test by fully opening and closing the element throughout the test. This interval will depend on a number of variables. The best indicator of the need to reset is increasing pull forces or decreasing extendible element travel. The resetting interval shall not be less than 500 cycles.

- d) Upon completion of the cycles, perform the Pull Force Test in Section 19.
- e) If the extendible element is equipped with an interlock device, perform the Interlock Test in Section 13.
- f) Repeat the test as necessary for each extendible element type per Section 3.1.4.

10.2.3 Acceptance Level

There shall be no loss of serviceability. Before and after the cycle test, the extendible element(s) shall meet the pull force requirements of Section 19. After the cycle test, the extendible elements, if applicable shall meet the interlock test requirements of Section 13.

10.3 Cycle Test for Extendible Elements Wider Than Deep

Note: Center/Pencil Drawers are tested per Section 10.4

10.3.1 Test Setup

- a) The unit shall be placed on a test platform, leveled, and secured against movement. Prior to performing test procedure, the extendible element, if equipped with an interlock device, shall meet the interlock test requirements of Section 13.
- b) Extendible element being tested shall be uniformly loaded to the functional load per Table 1 (See page 20). Load shall be configured per Section 3.9.
- c) The cycling device shall be connected to the extendible element pull per Table 2 (See page 21)
- d) The cycling device shall be set to cause the extendible element to travel within 0 to 6 mm (0 to 0.25 in.) of the closed position to 0 to 6 mm (0 to 0.25 in.) of the fully extended position and return. This amount of travel shall constitute one cycle. The cycling device shall not support or add vertical or horizontal loads to the suspensions.
- e) The cycling device shall be operated at a rate of 12 ± 4 cycles per minute.

10.3.2 Test Procedure

- a) Prior to performing test procedure, the extendible element shall be tested to and meet the pull force requirements of Section 19.
- b) The extendible element shall be subjected to testing as defined in Section 10.2.2(d) and (e) and Table 4 (See page 55).
- c) The suspensions shall not be cleaned or lubricated during the test.

Note: When necessary to compensate for ball-bearing cage creep the extendible element should be reset throughout the test by fully opening and closing the element throughout the test. This interval will depend on a number of variables. The best indicator of the need to reset is increasing pull forces or decreasing extendible element travel. The resetting interval shall not be less than 500 cycles.

- d) Upon completion of the cycles, perform the Pull Force Test in Section 19.
- e) If the extendible element is equipped with an interlock device, perform the Interlock Test in Section 13.
- f) Repeat the test as necessary for each extendible element type per Section 3.1.4.

Table 4
Cycle Test for Extendible Elements Wider Than Deep

Pull Type	Cycles per Location
single pull \leq 33% extendible element width (center pulls and single side pulls)	50,000 cycles at center of pull
single pull $>$ 33% extendible element width (wide width pulls)	30,000 cycles at center of pull 10,000 cycles at Right Hand position (see test setup) 10,000 cycles at Left Hand position (see test setup)
dual pulls	25,000 cycles at center of Right Hand pull 25,000 cycles at center of Left Hand pull

10.3.3 Acceptance Level

There shall be no loss of serviceability. Before and after the cycle test, the extendible element(s) shall meet the pull force requirements of Section 19. After the cycle test, the extendible elements, if applicable shall meet the interlock test requirements of Section 13.

10.4 Cycle Test for Center/Pencil Drawers

10.4.1 Test Setup

- a) The unit shall be placed on a test platform, leveled, and secured against movement.
- b) Center/pencil drawer shall be uniformly loaded per Table 1 (See page 20). Load shall be configured per Section 3.9.2.
- c) The cycling device shall be connected to the center of the center/pencil drawer's pull.
- d) The cycling device shall be set to cause the extendible element to travel within 0 to 6 mm (0 to 0.25 in.) of the closed position to 0 to 6 mm (0 to 0.25 in.) of the fully extended position and return. This amount of travel shall constitute one cycle. The cycling device shall not support or add vertical or horizontal loads to the suspensions.
- e) The cycling device shall be operated at a rate of 12 ± 4 cycles per minute.

10.4.2 Test Procedure

- a) Prior to performing test procedure, the center/pencil drawer shall be tested to and meet the pull force requirements of Section 19.
- b) The center/pencil drawer shall be subjected to 10,000 cycles per Section 10.4.1(d) and 10.4.1(e). The suspensions shall not be cleaned or lubricated during the test.

Note:

When necessary to compensate for ball-bearing cage creep the extendible element should be reset throughout the test by fully opening and closing the element throughout the test. This interval will depend on a number of variables. The best indicator of the need to reset is increasing pull forces or decreasing extendible element travel. The resetting interval shall not be less than 500 cycles

- c) Upon completion of the cycles, perform the Pull Force Test in Section 19.

10.4.3 Acceptance Level

There shall be no loss of serviceability. Before and after the cycle test, the center/pencil drawer shall meet the pull force requirements of Section 19.

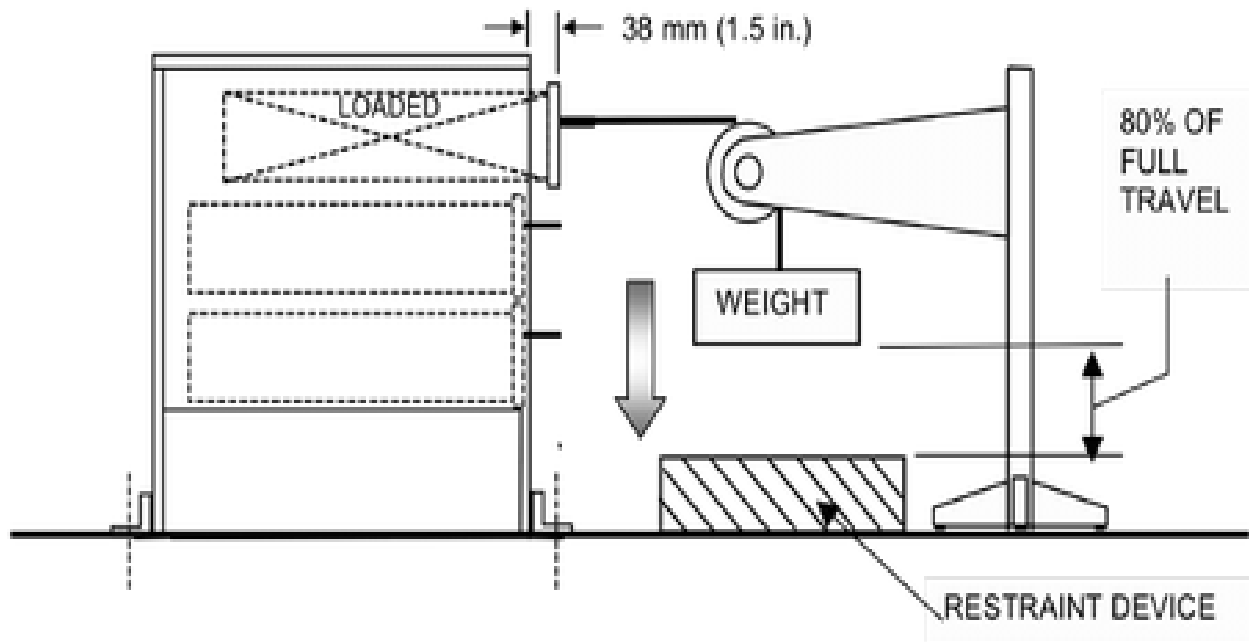

Figure 11a – Extendible Element Retention Impact Test

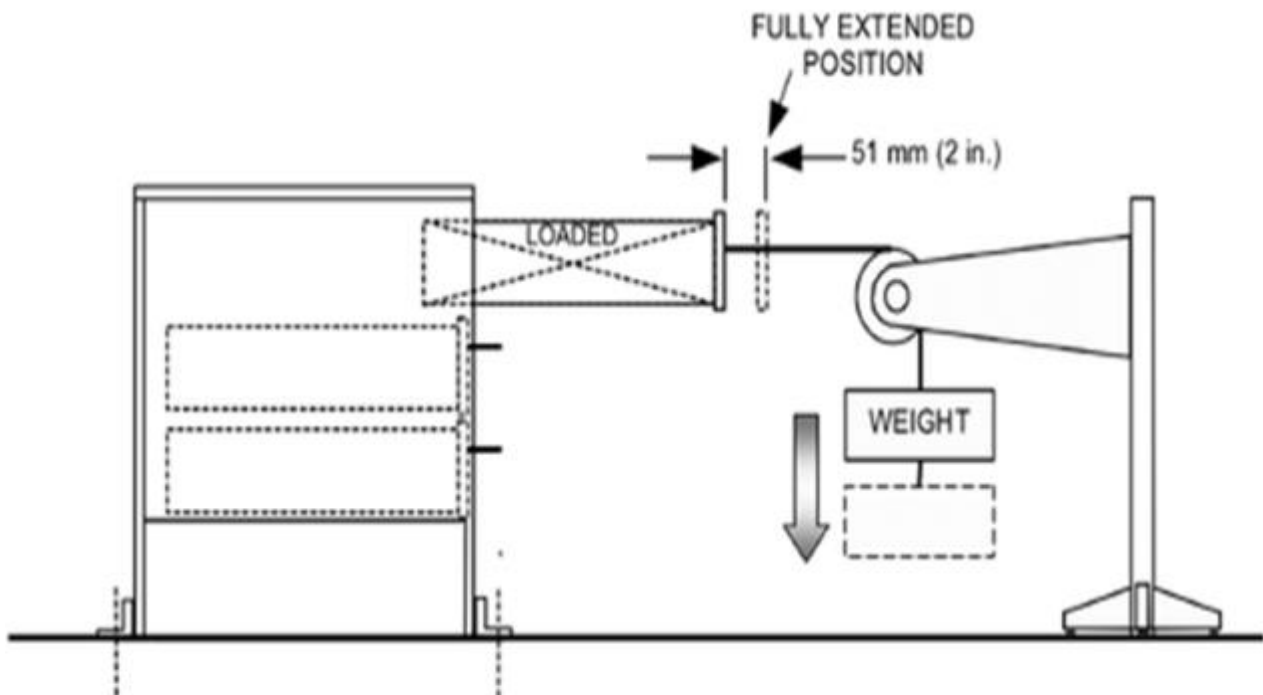

Figure 11b – Extendible Element Retention Durability Test

11 Extendible Element Retention Impact and Durability Tests (See Figures 11a and 11b)

11.1 Purpose of Test

The purpose of this test is to evaluate the ability of extendible elements to withstand excessive pullout forces. This test does not apply to elements with load capacity per Table 1 (See page 20) of less than 7 kg (15.4 lb.).

11.2 Test Setup

- a) The unit shall be placed on a test platform and leveled. The unit shall be affixed with obstruction(s) to prevent it from moving. Obstructions shall not interfere with the operation of the extendible element(s) being tested.
- b) The extendible element being tested shall be uniformly loaded to the functional load per Table 1 (See page 20). Load shall be configured per Section 3.9.
- c) A stranded metallic cable shall be attached to the most rigid point of the vertical centerline of the extendible element. This may be accomplished by means of a clamp or similar device that does not affect the test results.
- d) The opposite end of the cable shall extend horizontally to a pulley and then downward to an attached weight. Open the extendible element 38 mm (1.5 in.) and determine the minimum weight that will cause the extendible element to open to full extension. Add 2.3 kg (5 lb.) of weight. This combined weight shall be used to conduct the test. The weight shall contact the restraint device after the extendible element reaches 80% of the extendible element's total extension. See Figure 11a.

11.3 Test Procedure

- a) Prior to performing test procedure, the extendible element shall meet the pull force requirements of Section 19.
- b) The extendible element with cable and hanging weight shall be held in a position 38 mm (1.5 in.) from closed and the extendible element shall be released, permitting the extendible element to open rapidly, and allowing it to impact the out stops. Repeat this procedure for a total of 5 times without resetting the air gaps specified in the Loading Guidelines (Section 3.9). (See Figure 11a)
- c) Remove the weight restraint. Move the fully extended extendible element 51 mm (2 in.) toward the closed position and then release it rapidly, allowing it to impact the out stop. The distance traveled by the weight shall not be restrained. This procedure shall be repeated 15,000 cycles at a rate of 14 ± 6 cycles per minute. (See Figure 11b).

Note:

When necessary to compensate for ball-bearing cage creep (ball-bearing slides only), the extendible element should be reset throughout the test by fully opening and closing the element throughout the test. This interval will depend on a number of variables. The best indicator of the need to reset is increasing pull forces or decreasing extendible element travel. The resetting interval shall not be less than 500 cycles.

- d) Upon completion of the cycles, perform the Pull Force Test in Section 19.
- e) Repeat the test as necessary for each element per Section 3.1.4.

11.4 Acceptance Level

There shall be no loss of serviceability or disengagement of the extendible element from the unit. After performing the Retention Tests, the extendible element shall meet the pull force requirements of Section 19.

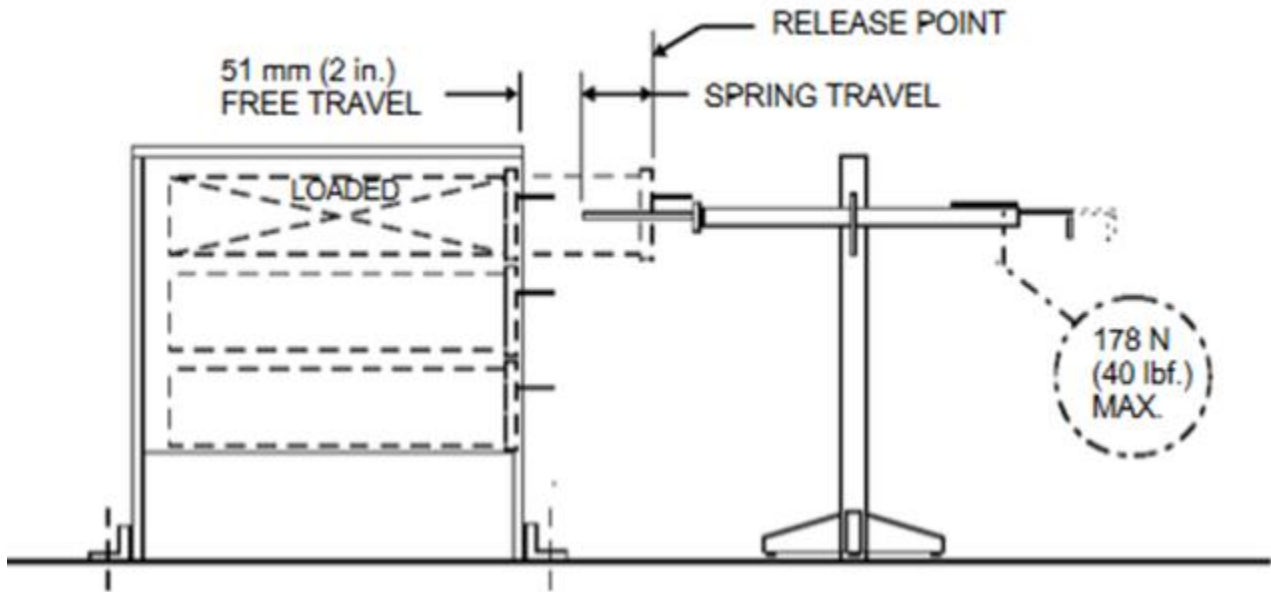

Figure 12 – Extensible Element Rebound Test

12 Extendible Element Rebound Test (See Figure 12)

This test does not apply to center/pencil drawers.

12.1 Purpose of Test

The purpose of this test is to evaluate the operational characteristics of a loaded extendible element to ensure that it will not bounce back out of the unit beyond the acceptance level while being closed.

12.2 Test Setup

- a) The unit shall be placed on a test platform and leveled. The unit shall be affixed with obstruction(s) to prevent it from moving. Obstructions shall not interfere with the operation of the extendible element(s) being tested.
- b) The extendible element to be tested shall be loaded to the functional load requirements in Table 1 (See page 20). Load per Section 3.9.3 (Figure 3a or 3b) if extendible element has a bottom. Load per Section 3.9.4 (Figure 3c or 3d) if extendible element does not have a bottom, whichever is worst-case (or test to both if the worst-case cannot be determined).

12.3 Test Procedure

- a) Prior to performing the test procedure, the extendible element shall be tested to and meet the pull force requirements of Section 19.
- b) A force gauge with a spring rate of 1.75 N/mm (10 lbf./in.) shall be mounted 51 mm (2.0 in) from the face of the extendible element in its fully closed position per Figure 12
- c) The extendible element shall be opened (through the free travel space) against the force gauge to a force of 9.8 N per kg (1 lbf./pound) of extendible element load or 178 N (40 lbf.), whichever force is less.
- d) Release the extendible element allowing the force applied by the force gauge to close the extendible element. Record the at-rest position of the extendible element after rebound.
- e) Reset the position of the load to meet the air gap requirements of Section 3.9.
- f) Repeat steps (c) through (e) for a total of 5 times.
- g) Repeat the test as necessary for each extendible element type per Section 3.1.4.

12.4 Acceptance Level

There shall be no loss of serviceability. The rebound position of the extendible element shall not exceed 38 mm (1.5 in.) from its closed position after each of the five closings.

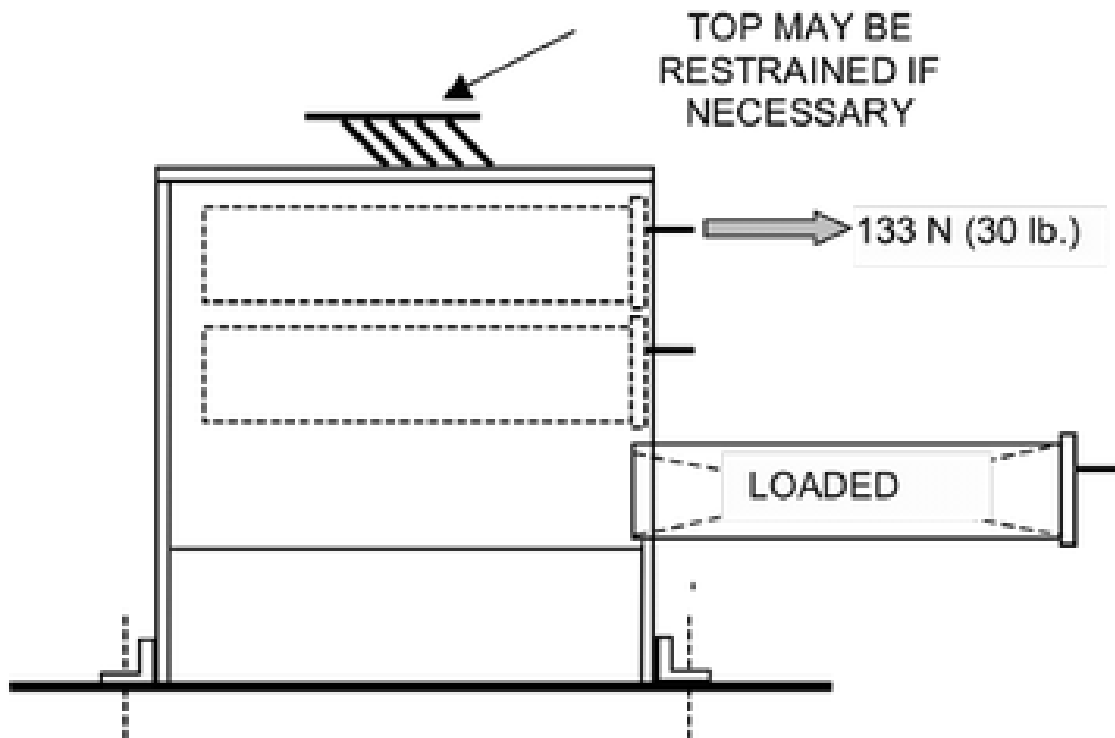

Figure 13 – Interlock Strength Test

13. Interlock Strength Test (See Figure 13)**13.1 Purpose of Test**

The purpose of this test is to evaluate the ability of the interlock system to withstand horizontal forces that may be applied to defeat the interlock (if present).

Note: This test may be conducted in conjunction with the Extendible Element Cycle Test (Section 10).

13.2 Test Setup

The unloaded unit shall be placed on a test platform, leveled, and secured against movement in any direction.

13.3 Test Procedure

- a) An extendible element shall be fully extended, and a horizontal force of 133 N (30 lbf.) shall be individually applied to the center of the pull area(s) of the remaining extendible elements, one at a time.
- b) Repeat step(a) until all possible combinations of extendible elements have been tested
- c) Load extendible elements with the functional load per Table 1 (See page 20)
- d) Repeat steps (a) and (b) until all possible combinations of extendible elements have been tested.

13.4 Acceptance Level

There shall be no loss of serviceability to the interlock system. The unopened extendible elements shall not bypass the interlock system.

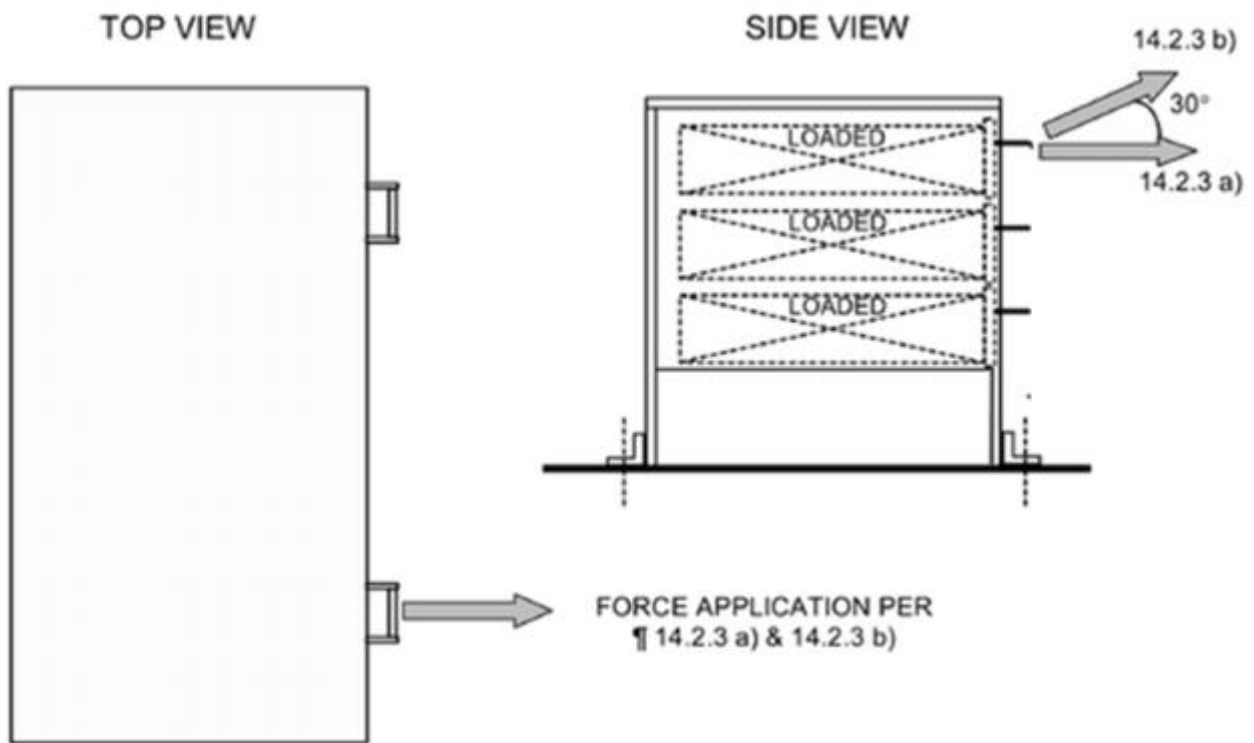

Figure 14a – Force Test for Extendible Element Locks

14 Lock Tests

14.1 Purpose of Tests

The purpose of these tests is to evaluate the ability of locks to function.

14.2 Force Test for Extendible Element Locks (See Figure 14a)

14.2.1 Purpose of Test

The purpose of these tests is to evaluate the ability of locking mechanism, if present, to provide a nominal amount of security for the contents.

14.2.2 Test Setup

- a) The unit shall be placed on a test platform, leveled and secured to prevent it from moving. The method of securing shall not interfere with the operation of the extendible element(s) being tested.
- b) Close and lock all extendible elements.
- c) Depending on the pull configuration, set up test to apply force to the pull per Table 2 (See page 21).

14.2.3 Test Procedure

- a) A horizontal outward force of 222 N (50 lbf.) shall be applied once at each of the applicable locations indicated in the test setup.
- b) An outward and upward force (30 degrees from horizontal) of 222 N (50 lbf.) shall be applied once at each of the applicable locations indicated in the test setup.

Note:

If the extendible element pull design does not allow a user to apply an outward and upward force, step (b) does not apply.

- c) Repeat steps (a) and (b) for each extendible element.
- d) Unlock the extendible elements.
- e) All extendible elements in the unit shall be uniformly loaded with the functional load per Table 1 (See page 20). Any uniform loading configuration in Section 3.9 (Figure 3a -3d) is acceptable.
- f) The loaded extendible elements shall be closed and locked.
- g) Repeat procedure (a) through (d).

14.2.4 Acceptance Level

The extendible elements shall remain in the normal locked position during application of the forces. There shall be no loss of serviceability of the locking mechanism.

EXAMPLE WITH HINGED DOOR

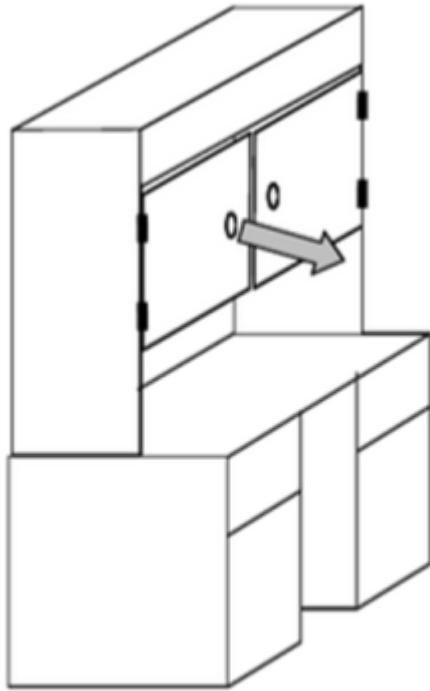

EXAMPLE WITH SLIDING DOOR

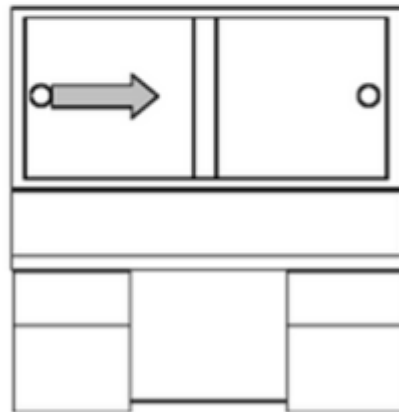

Figure 14b - Force Test for Door Locks

14.3 Force Test for Door Locks (See Figure 14b)

14.3.1 Purpose of Test

The purpose of these tests is to evaluate the ability of locking mechanism, if present, to provide a nominal amount of security for the contents.

14.3.2 Test Setup

- a) The unit shall be placed on a test platform and leveled. The unit shall be secured to prevent it from moving. The method of securing shall not interfere with the operation of the doors being tested.
- b) Close and lock all doors.
- c) Apply forces to the center of the pull area of the door.

14.3.3 Test Procedure

- a) Apply a force of 222 N (50 lbf.) in the direction of initial door travel.
- b) Repeat the test as necessary for each door/lock per Section 3.1.4.
- c) Unlock the door.

14.3.4 Acceptance Level

The doors shall remain in the normal locked position during application of the forces. There shall be no loss of serviceability of the locking mechanism.

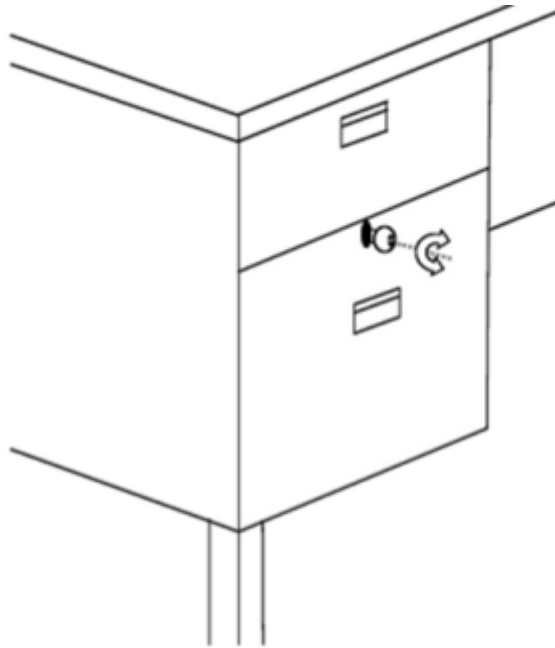

Figure 14c - Locking Mechanism Cycle Test

14.4 Locking Mechanism Cycle Test (See Figure 14c)

14.4.1 Purpose of Test

The purpose of this test is to evaluate the durability of locking mechanisms.

14.4.2 Test Setup

- a) The unit shall be placed on a test platform and leveled.
- b) For keyed locks, insert the key into the lock and attach a cycling device to the head of the key. For keyless locks, attach a cycling device to the keypad or unlocking mechanism. If the design of the locking mechanism requires activation of the extendible element or door to fully evaluate the mechanism, the extendible element or door may be opened/closed accordingly during the test. This activation may be done independent of the key cycling.
- c) Set the cycling device to operate at 14 ± 6 cycles per minute.

14.4.3 Test Procedure

- a) Cycle the locking mechanism through its full range of motion for 5000 cycles. Each cycle shall consist of a complete locking and unlocking of the mechanism. For keyed systems, the key does not need to be removed from the lock mechanism. For keyless systems, the cycle may require two activations of the keypad – one to lock and one to unlock.
- b) Repeat the test on each type of locking mechanism per Section 3.1.4.

14.4.4 Acceptance Level

There shall be no loss of serviceability of the locking mechanism.

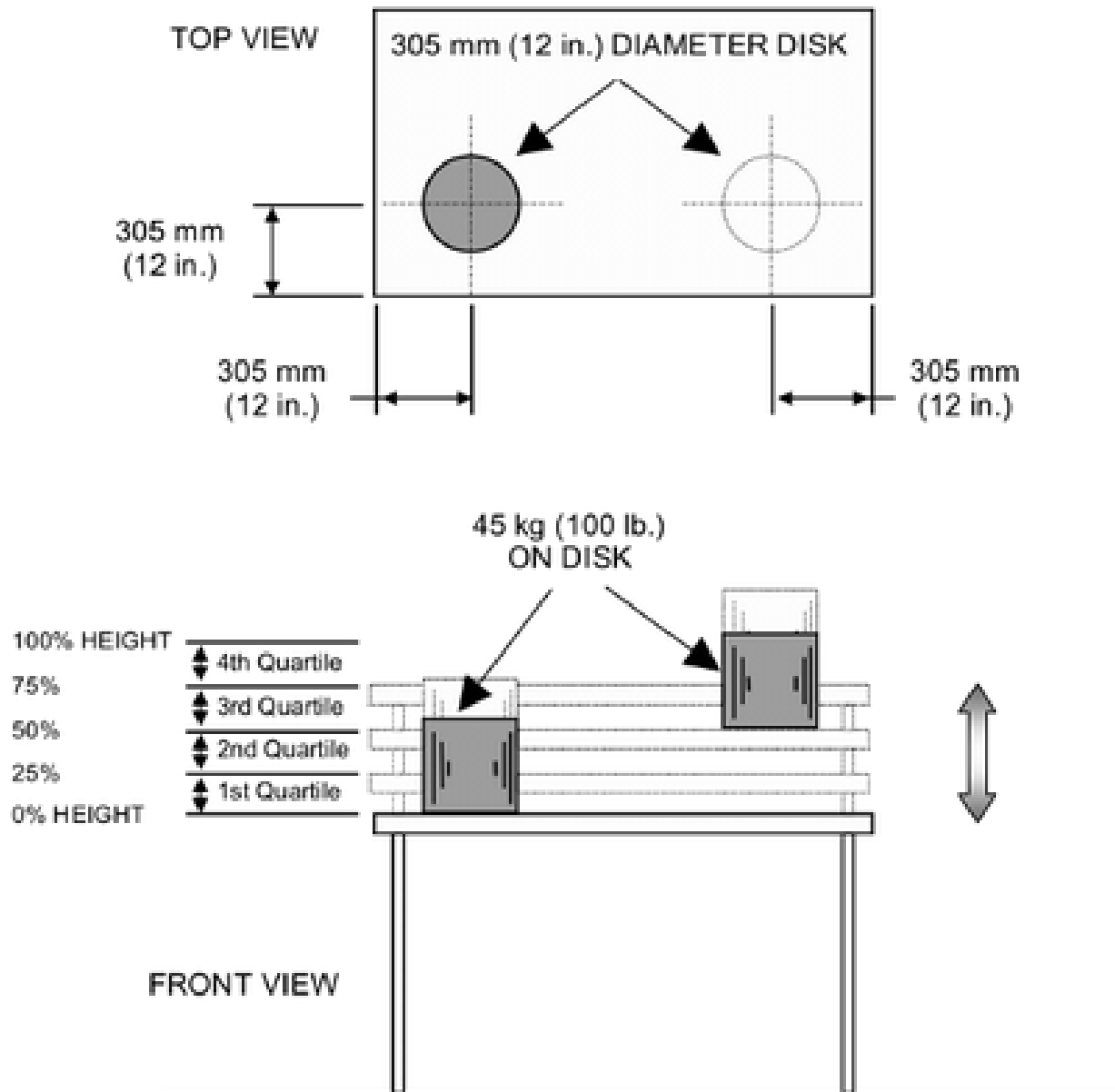

Figure 15 – Work Surface Vertical Adjustment Test

15 Work Surface Vertical Adjustment Test (See Figure 15)

This test does not apply to adjustable tables with only counterbalancing force type (spring loaded and/or pneumatic lift device) adjustment mechanisms. This test does not apply to adjustable keyboard surfaces; they shall be tested per Section 16.

15.1 Purpose of Test

The purpose of this test is to evaluate the ability of user adjustable surfaces to be cycled through their range of adjustment under load.

15.2 Test Setup

a) The unit shall be leveled in the normal operating position and secured to the test platform.

b) Apply a test load of 45 kg (100 lb.) through a 305 mm (12 in.) diameter disk with the center of the disk on a line 305 mm (12 in.) in from the working edge of the surface or at the midpoint, whichever is nearer the working edge.

The side-to-side position of the test load is described in Test Procedure Section 15.3 a). For crank-adjusted height adjustment mechanisms, determine the force to adjust the table prior to testing for the first-quartile cycling. Determine the maximum force throughout one crank revolution in the raising direction. The cycle rate for electrically driven tables shall be as recommended by the manufacturer. When the duty cycle is not recommended by the manufacturer, the duty cycle shall be three cycles on then off for the time it takes to run 15 cycles.

15.3 Test Procedure

a) The unit, including any latches or activation mechanisms, shall be cycled for 1000 cycles in each quartile of full travel for a total of 4000 cycles as described below:

Note:

The test device shall apply the forces necessary to achieve the motion required. The latching and/or activating mechanisms may be cycled concurrently or independently for 4000 cycles.

First Quartile:

The unit shall be cycled from the lowest to the 25% position. The center of the loading disk shall be positioned 305 mm (12 in.) in from the left edge of the surface.

Second Quartile:

The unit shall be cycled from the 25% to the 50% position. The center of the loading disk shall be positioned 305 mm (12 in.) in from the left edge of the surface.

Third Quartile:

The unit shall be cycled from the 50% to the 75% position. The center of the loading disk shall be positioned 305 mm (12 in.) in from the right edge of the surface.

Fourth Quartile:

The unit shall be cycled from the 75% up to the highest position.

- b) One cycle is travel/movement from the lowest position to the highest position within a quartile and return.
- c) The cycle rate shall not exceed 6 cycles per minute or the manufacturer's recommended rate.
- d) For crank-adjusted height adjustment mechanisms, determine the force to adjust the table after completion of (a), Fourth Quartile cycling. Determine the maximum force throughout one complete raising and lowering adjustment.

15.4 Acceptance Level

There shall be no loss of serviceability to the unit. For tables with crank driven height adjustment mechanisms, the operating force on the handle to adjust the table shall not exceed 50 N (11.2 lbf.) before or after the test.

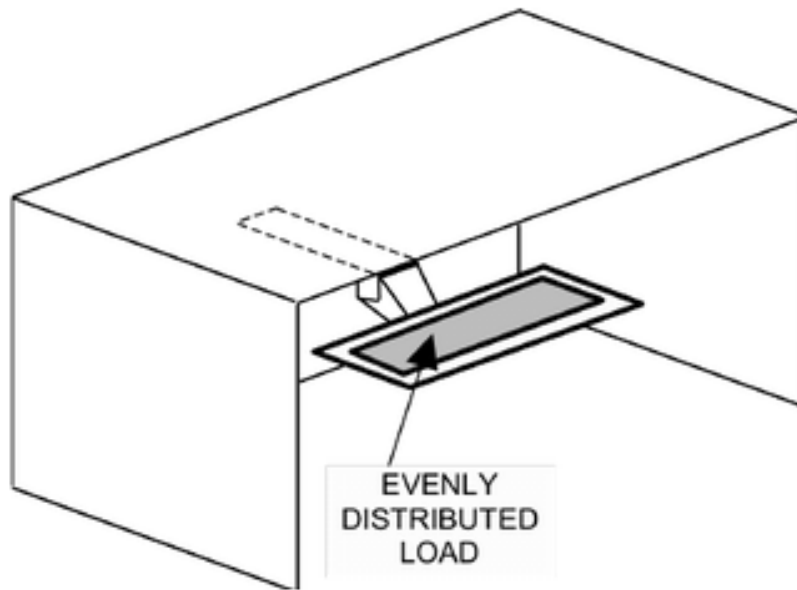

Figure 16 - Keyboard Support and Input Device Support Adjustment Tests

16 Keyboard Support and Input Device Support Adjustment Tests. (See Figure 16)**16.1 Purpose of Test**

The purpose of this test is to evaluate the ability of adjustable keyboard supports and input device supports (mouse pads) to be cycled through their range of adjustment under load.

16.2 Test Setup

- a) The surface to which adjustable keyboard support and/or input device support are attached shall be leveled in the normal operating position and secured.
- b) Apply an evenly distributed 4.5 kg (10 lb.) load across the keyboard support surface. If the device does not have a surface (keyboard attaches directly to the device), a test surface may be added to simulate a keyboard support surface.
- c) Apply an evenly distributed 2.3 kg (5 lb.) load across the input device support surface (if it is a separate surface from the keyboard support surface).
- d) The cycling device shall be set to operate at rate not to exceed 6 cycles per minute.

16.3 Test Procedure

The adjustable keyboard support and input device support shall be subjected to 2500 cycles each as follows:

- a) Horizontal Motion; within 6 mm (0.25 in.) of the end stops.
- b) Vertical Motion; within 6 mm (0.25 in.) of the end stops.
- c) Swivel Motion; minimum of 120 degrees of adjustment, or to within 6 mm (0.25 in.) of the end stops over its full range of motion, whichever is less.

Note:

Individual adjustment motions may be tested one at a time. The cycling device shall neither add load nor provide vertical support during horizontal or swivel adjustment testing, unless the product design requires load to activate the mechanism in accordance with Section 3.2.

16.4 Acceptance Level

There shall be no loss of serviceability.

17 Door Tests

Table 5 provides a guide for the appropriate test by door type.

17.1 Purpose of Tests

The purpose of these tests is to evaluate the performance of desk/table unit doors.

Table 5 - Door Test Applicability

Door Type/Test	Strength Tests	Cycling wear & fatigue tests	Slam Tests	Lock Tests	Latch Test	Pull Test
Vertically Hinged Doors, Bi-fold and Multi-fold Doors	17.2 & 17.3	17.6	17.10	14.3 & 14.4	17.14	19
Horizontally Hinged Doors	5.3 & 5.4 for bottom hinged doors. n/a for top-hinged doors	17.6	17.11 n/a for bottom-hinged doors	14.3 & 14.4	17.14	19
Vertical Receding Doors	17.2, 17.3 & 17.4	17.6, 17.7 & 17.9	17.10	14.3 & 14.4	17.14	19
Horizontal Receding Doors	17.5	17.6, 17.8 & 17.9	17.11	14.3 & 14.4	17.14	19
Horizontally Sliding/ Roll Front	n/a	17.6	17.12 or 17.13	14.3 & 14.4	17.14	19
Tambour	n/a	17.6	17.12 or 17.13	14.3 & 14.4	17.14	19

n/a = not applicable

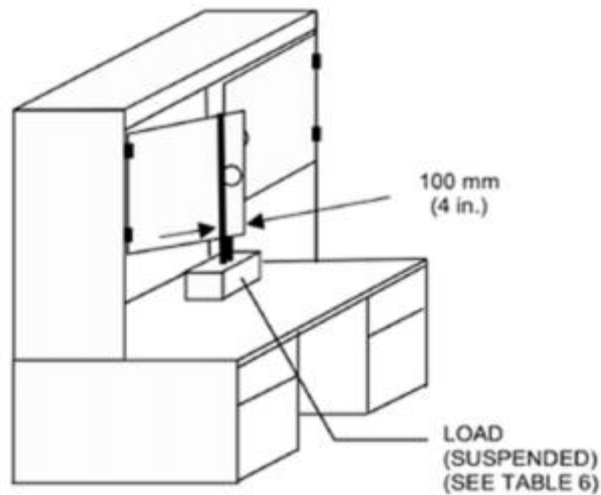

Figure 17a - Strength Test for Vertically Hinged Doors, Bi-fold Doors, and Vertically Receding Doors

17.2 Strength Test for Vertically Hinged Doors, Bi-fold Doors and Vertically Receding Doors (See Figure 17a)

Note: this test does not apply to multi-fold (accordion) doors.

17.2.1 Purpose of Test

The purpose of this test is to determine the ability of doors to withstand excessive vertical loads.

17.2.2 Test Setup

- a) The unit shall be placed on a test platform, leveled, and secured against movement.
- b) Attach the specified load per Table 6 so that it is equally distributed on both sides of the door and its center of gravity acts 100 mm (4 in.) from the edge of the door opposite the hinge.

Table 6 - Door Height vs. Load

Door height	Load
Less than 46 cm (18 in.).	10 kg (22 lb.)
46 cm (18 in.) and greater	20 kg (44 lb.)

Receding doors should be tested in the fully extended position. For bi-fold doors, attach the load so that it is applied to the section of the door farthest from the point where the hinge(s) is (are) attached to the frame in a manner that does not affect the operation of the door.

17.2.3 Test Procedure

Cycle the door 10 times from a position 45 degrees from fully closed to a position 10 degrees from fully open (but not more than 135 degrees) and return. For bi-fold doors, cycle the door from a position 50 mm (2 in.) from fully closed to a position 50 mm (2 in.) from fully open and return.

17.2.4 Acceptance Level

There shall be no loss of serviceability to the unit.

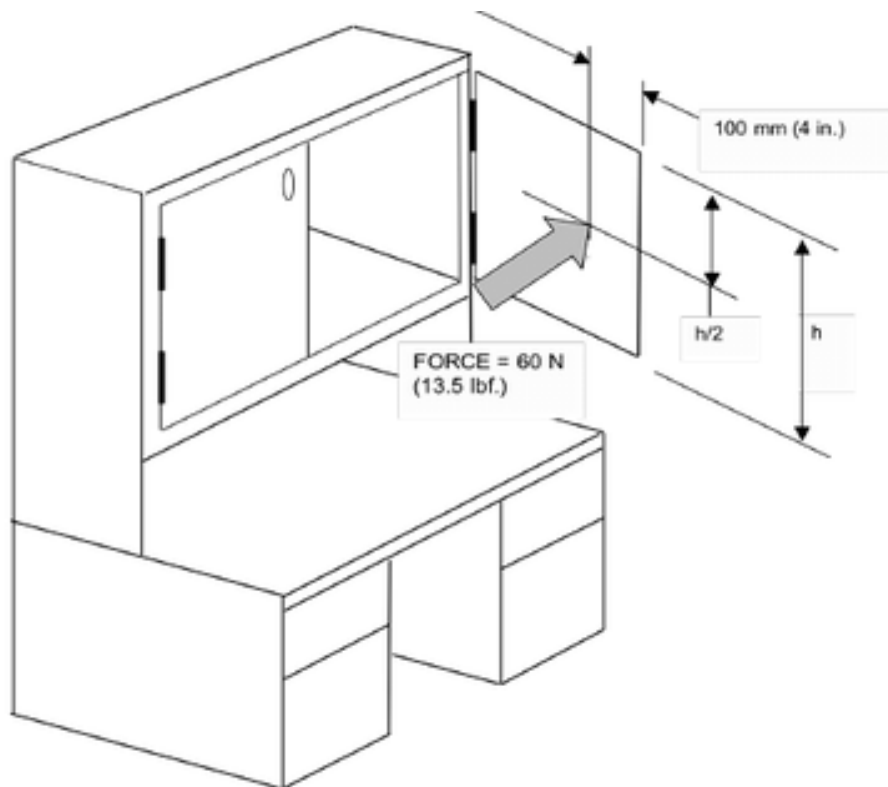

Figure 17b - Hinge Override Test for Vertically Hinged Doors

17.3 Hinge Override Test for Vertically Hinged Doors (See Figure 17b)**17.3.1 Purpose of Test**

The purpose of this test is to determine the ability of a vertically hinged door to resist forces that override the limit of the motion allowed by the hinge.

17.3.2 Test Setup

The unit shall be placed on a test platform, leveled, and secured against movement

17.3.3 Test Procedure

- a) Apply a 60 N (13.5 lbf.) horizontal force perpendicular to the plane of the door on its horizontal centerline 100 mm (4 in.) from the edge farthest from the hinge, as shown in Figure 17b

17.3.4 Acceptance Level

There shall be no loss of serviceability to the desk/table unit or its components.

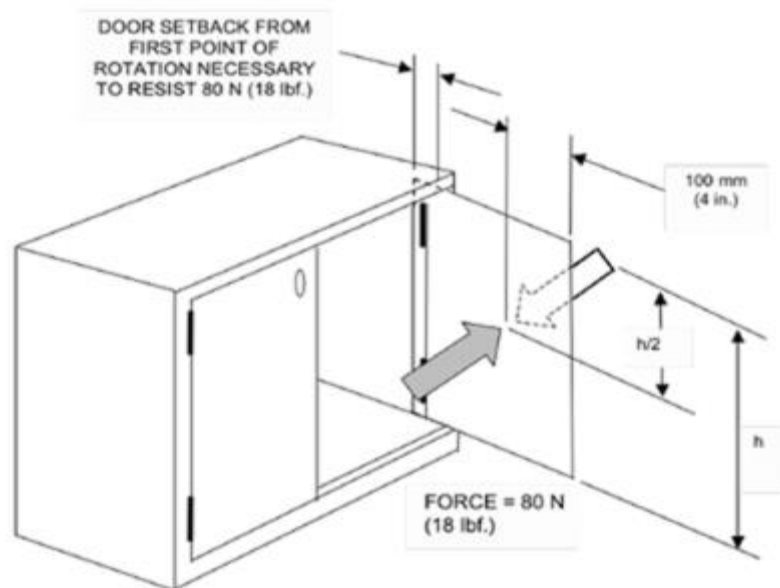

Figure 17c – Vertical Receding Doors Strength Test

17.4. Vertical Receding Doors Strength Test (See Figure 17c)**17.4.1 Purpose of Test**

The purpose of this test is to determine the ability of a vertical receding door to resist forces that override the pocket.

17.4.2 Test Setup

- The unit shall be placed on a test platform, leveled, and secured against movement
- Move the door from its stowed position to the first point at which the door will rotate freely towards its closed position.
- Place the receding door in a position rearward from this point until the door will resist an 80N (18 lbf.) force without closing.

17.4.3 Test Procedure

- Apply the 80 N (18 lbf.) horizontal force perpendicular to the plane of the door on its horizontal centerline 100 mm (4 in.) from the edge farthest from the hinge, as shown in Figure 17c.
- Apply the force 10 times.
- Repeat the test with the force application to the opposite side of the door.

17.4.4 Acceptance Level

There shall be no loss of serviceability to the desk/table unit or its components.

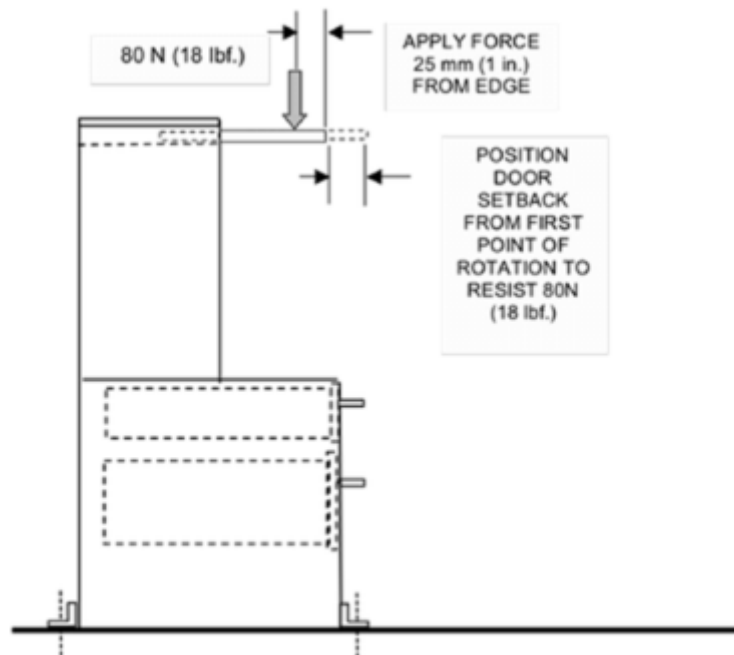

Figure 17d – Horizontal Receding Doors Strength Test

17.5 Horizontal Receding Doors Strength Test (See Figure 17d)

17.5.1 Purpose of Test

The purpose of this test is to determine the ability of a horizontal receding door to resist forces that override the pocket

17.5.2 Test Setup

- a) The unit shall be placed on a test platform, leveled, and secured against movement.
- b) Move the door from its stowed position to the first point at which the door will rotate freely towards its closed (vertical) position. Place the receding door in a position rearward from this point until the door will resist an 80 N (18 lbf.) force without closing.

17.5.3 Test Procedure

- a) Apply the 80 N (18 lbf.) downward force perpendicular to the plane of the door on its horizontal centerline 25 mm (1 in.) from the edge farthest from the hinge, as shown in Figure 17d.
- b) Apply the force 10 times.

17.5.4 Acceptance Level

There shall be no loss of serviceability to the desk/table unit or its components

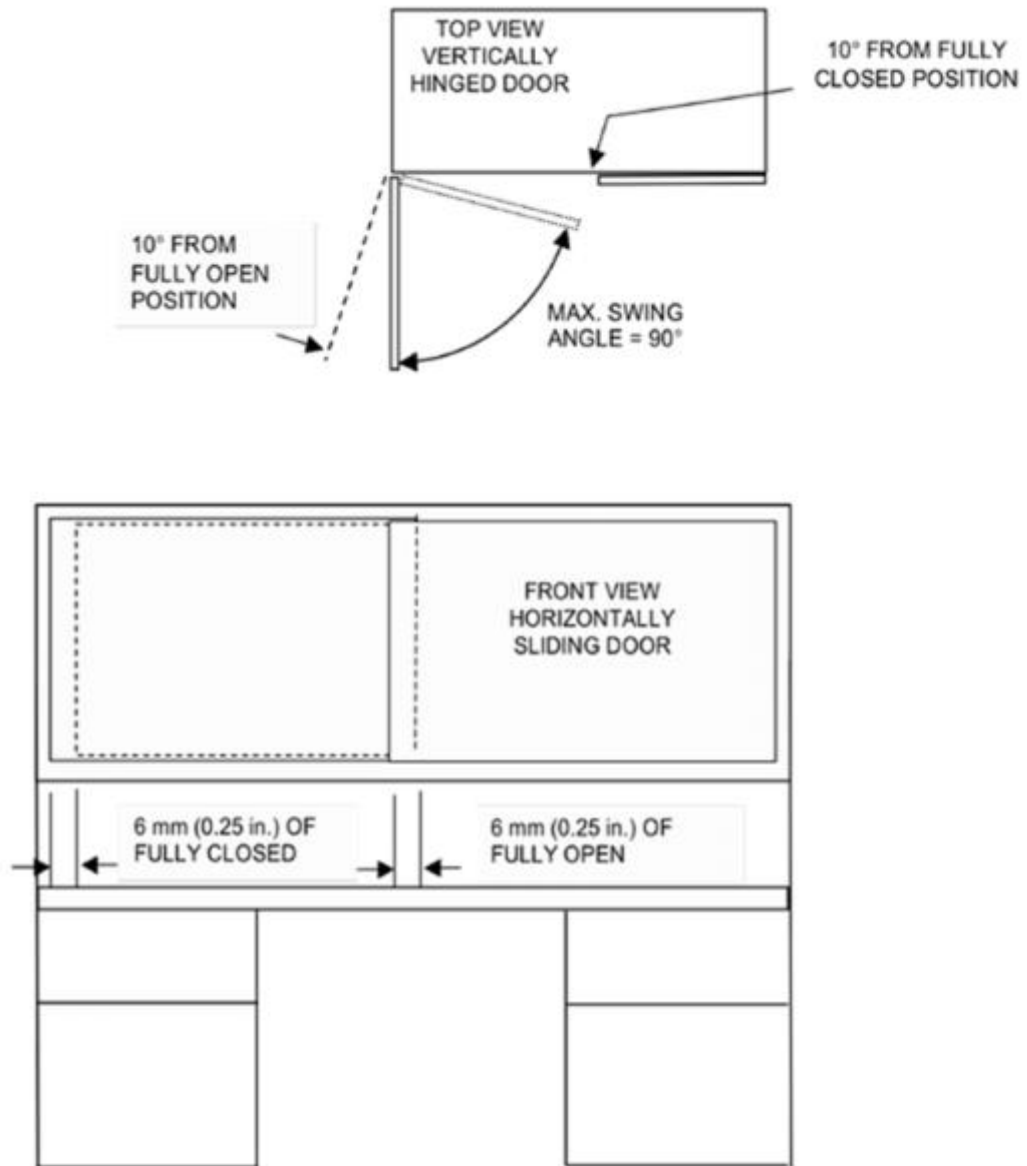

Figure 17e - Wear and Fatigue Test for Hinged, Horizontally Sliding, and Tambour Doors

17.6 Wear and Fatigue Test for Hinged, Horizontally Sliding, and Tambour Doors
(See Figure 17e)

17.6.1 Purpose of Test

The purpose of this test is to evaluate the resistance of hinged, horizontally sliding, and tambour doors to wear and fatigue.

17.6.2 Test Setup

17.6.2.1 The unit shall be placed on a test platform, leveled, and secured against movement.

17.6.2.2 Latches may be disabled if not tested in conjunction with the Door Latch Test (Section 17.14). Doors that have the ability to retract may have this feature disabled during the test.

17.6.2.3 Attach the cycling device to the door at its pull area per Table 2
(See page 21)

a) Cycle the door from a position 10 degrees from fully closed to a position 10 degrees from fully open and return, not to exceed a maximum swing angle of 90 degrees.

b) For doors that open and close along a track (such as bi-fold or multi-fold doors) cycle the door from within 6 mm (0.25 in.) of fully closed to within 6 mm (0.25 in.) of fully open and return.

17.6.2.4 The cycling device shall not be used to support or add to the weight of the door during the test.

Table 7 - Wear and Fatigue Tests for Doors

Pull Type	Cycles @ Location
narrow pull \leq 33% door width (center pulls and single side pulls)	20,000 cycles at center of pull.
wide pulls $>$ 33% of door width	10,000 cycles at center of pull 5000 cycles at one end of the pull (see test setup) 5000 cycles at the opposite end of the pull (see test setup)
dual pulls	10,000 cycles at center of one pull 10,000 cycles at center of the other pull

17.6.3. Test Procedure

Cycle the door for a total of 20,000 cycles as specified in Table 7 (See page 81)
The cyclic rate shall be 12 ± 4 cycles per minute unless the rate is controlled by the door operating mechanisms (pneumatic dampers, etc.). If that is the case, the rate shall not exceed the natural rate established by the movement of the mechanism.

17.6.4 Acceptance Level

There shall be no loss of serviceability to the desk/table unit or its components.

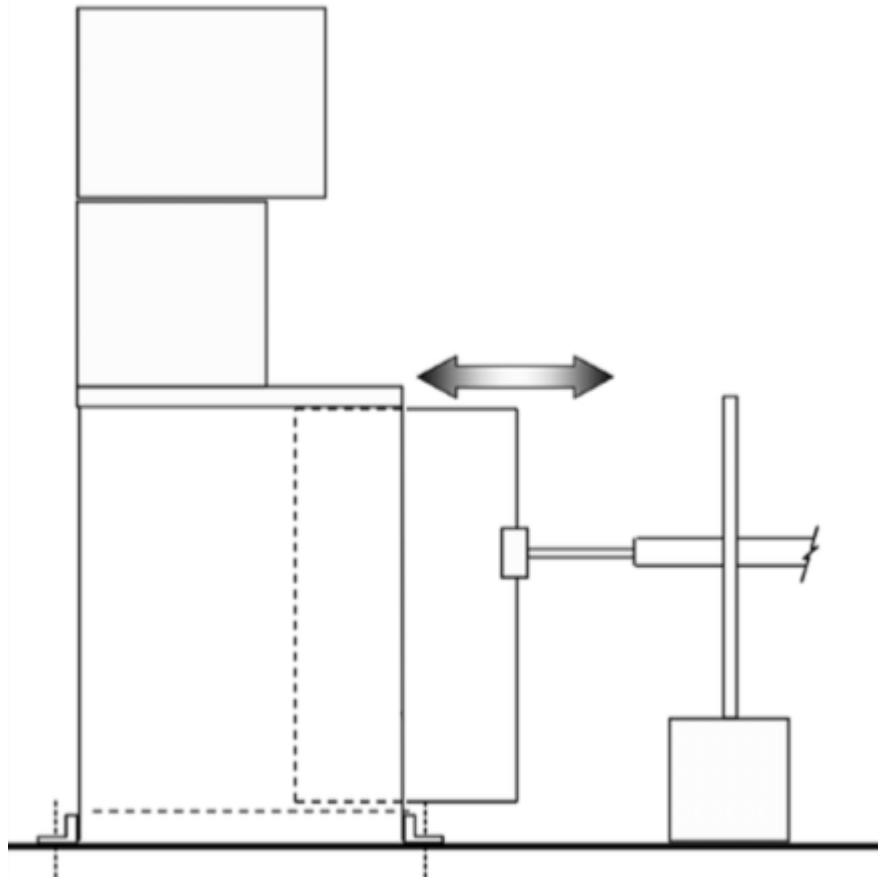

Figure 17f - Wear and Fatigue Test for Vertical Receding Doors

17.7. Wear and Fatigue Test for Vertical Receding Doors (See Figure 17f)**17.7.1 Purpose**

The purpose of this test is to evaluate the resistance of vertical receding doors to wear and fatigue.

17.7.2 Test Setup

- a) The unit shall be placed on a test platform, leveled, and secured against movement.
- b) The cycling device shall be connected to the leading edge of the door at the center of the pull area. If the unit to be tested has two or more identical doors, only one of them needs to be tested
- c) If not testing in conjunction with the Door Latch Test (Section 17.14), latches may be disabled.
- d) Adjust the cycling device to cause the door to travel between 0 to 6 mm (0 to 0.25 in.) of its fully extended and retracted positions.
- e) The cycling device shall not be used to support or add to the weight of the door during the test.
- f) The cycling device shall be set to operate at 12 ± 4 cycles per minute

17.7.3 Test Procedure

- a) Prior to performing test procedure, the door shall be tested to and meet the pull force requirements of Section 19.
- b) Cycle the door for a total of 10,000 cycles.
- c) The suspensions shall not be cleaned or lubricated during the test.

Note:

When necessary to compensate for ball-bearing cage creep (ball-bearing slides only) the door should be reset throughout the test by fully opening and closing the element throughout the test. This interval will depend on a number of variables.

The best indicator of the need to reset is increasing pull forces or decreasing door travel. The resetting interval shall not be less than 500 cycles.

- d) Upon completion of the cycles, perform the Pull Force Test in Section 19.

17.7.4 Acceptance Level

Before and after the cycle test, the door shall meet the pull force requirements of Section 19.

The door shall have no loss of serviceability.

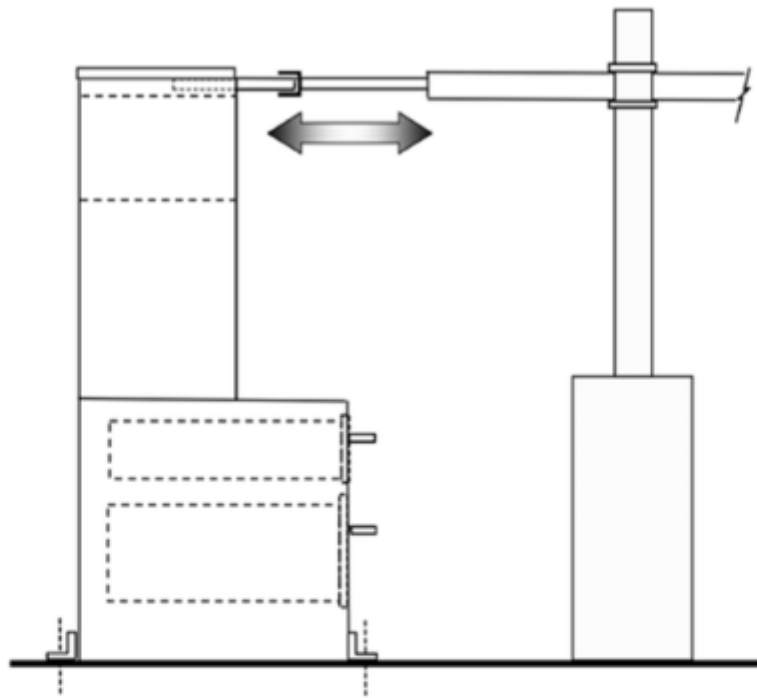

Figure 17g - Wear and Fatigue Test for Horizontal Receding Doors

17.8 Wear and Fatigue Test for Horizontal Receding Doors

(See Figure 17g)

17.8.1 Purpose of Test

The purpose of this test is to evaluate the resistance of horizontal receding doors to wear and fatigue.

17.8.2 Test Setup

- a) The unit shall be placed on a test platform, leveled, and secured against movement.
- b) The cycling device shall be connected to the leading edge of the door according to the attachment points given in Table 2 (See page 21)
- c) If not testing in conjunction with the Door Latch Test (Section 17.14), latches may be disabled.
- d) Adjust the cycling device to cause the door to travel between 0 to 6 mm (0 to 0.25 in.) of its fully extended and retracted positions.
- e) The cycling device shall be used to support the door in a horizontal plane during the test.
- f) The cycling device shall be set to operate at 12 ± 4 cycles per minute.

17.8.3 Test Procedure

- a) Prior to performing test procedure the door shall be tested to and meet the pull force requirements of Section 19. The door may be supported in a horizontal plane during the pull force measurement test.
- b) The door shall be cycled according to the requirements of Table 7 (See page 81)
- c) The suspensions shall not be cleaned or lubricated during the test.

Note:

When necessary to compensate for ball-bearing cage creep (ball-bearing slides only) the door should be reset throughout the test by fully opening and closing the element throughout the test. This interval will depend on a number of variables. The best indicator of the need to reset is increasing pull forces or decreasing door travel. The resetting interval shall not be less than 500 cycles

- d) Upon completion of the cycles, perform the Pull Force Test in Section 19.

17.8.4 Acceptance Level

Before and after the cycle test, the door shall meet the pull force requirements of Section 19. The door may be supported in a horizontal plane during the pull force test. The door shall have no loss of serviceability.

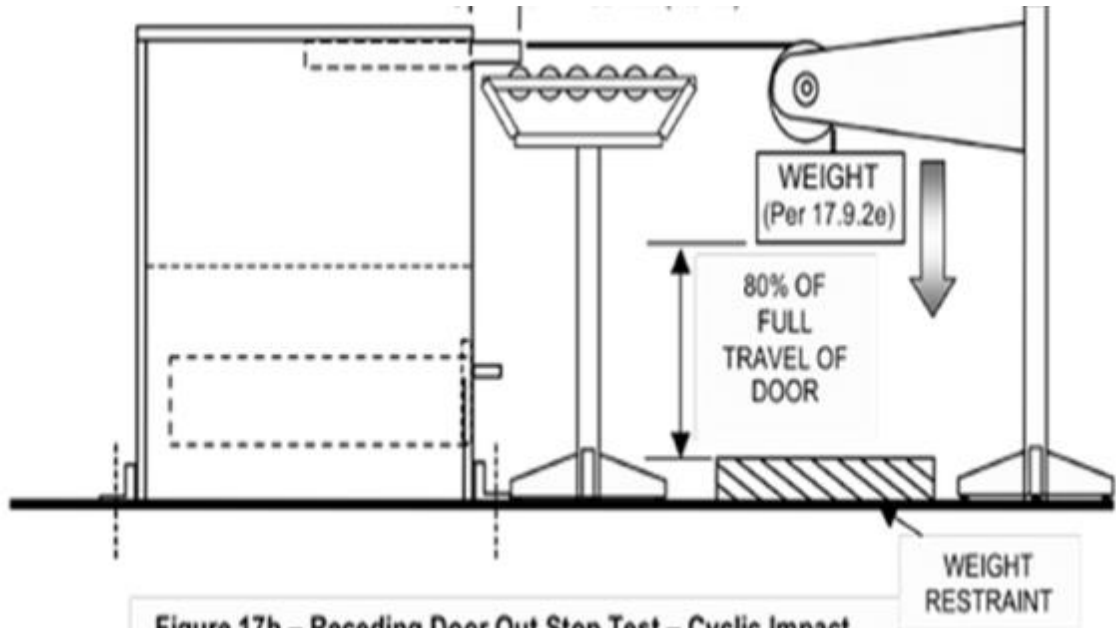

Figure 17h – Receding Door Out Stop Test – Cyclic Impact

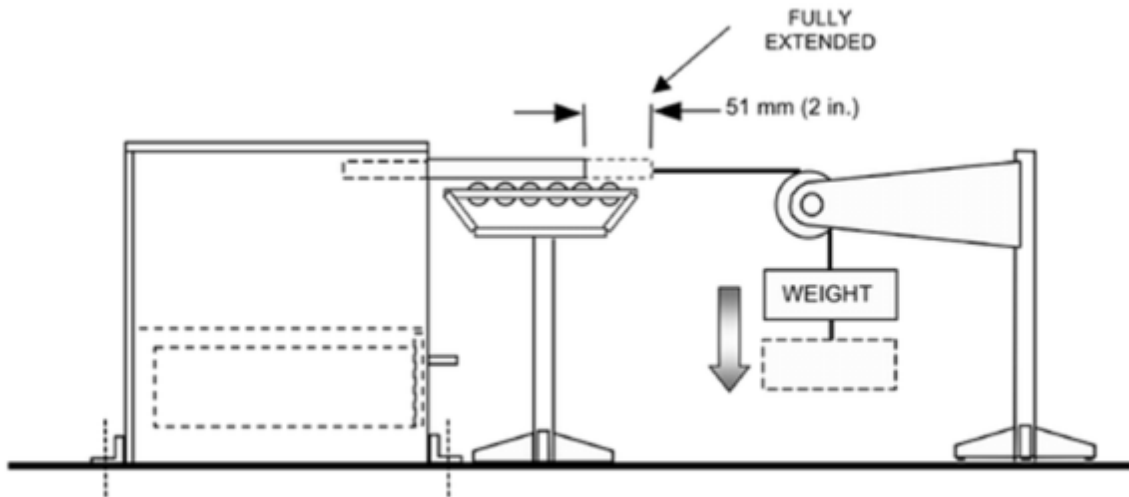

Figure 17i – Receding Door Out Stop Test – Cyclic Durability

17.9. Vertical and Horizontal Receding Door Out Stop Test – Cyclic Impact and Durability
(See Figures 17h and 17i)

17.9.1. Purpose of Test

The purpose of this test is to evaluate the ability of vertically or horizontally hinged receding doors to withstand excessive pullout forces.

17.9.2. Test Setup

- a) The unit shall be placed on a test platform, leveled, and secured to prevent it from moving. The method of securing shall not interfere with the operation of the door(s) being tested.
- b) A stranded metallic cable shall be attached at the center of the door or door-pull. This may be accomplished by means of a clamp or similar device that does not affect the test results.
- c) For a horizontally hinged door, the door shall be supported in a horizontal plane during the test. The method of support shall not impede the horizontal travel of the door.
- d) Prior to performing test procedure, the door shall be tested to determine the pull force per Section 19. For a horizontally hinged door the measurement shall be taken with the horizontal support device in place.
- e) The opposite end of the stranded metallic cable shall extend horizontally to a pulley and then downward to an attached weight. Open the door 38 mm (1.5 in.) from its stowed position. Add to the pull force determined in d) 1 kg (2.2 lb.) to the weight on the cable.
This combined weight shall be used to conduct the test. The weight shall contact the restraint after the door reaches 80% of the door's total extension. (See Figure 17h).

17.9.3. Test Procedure – Cyclic Impact Test

The door with stranded metallic cable and hanging weight shall be held 38 mm (1.5 in.) from the closed position and then released, permitting it to open rapidly (ensuring the weight is restrained according to 17.9.2(e) and impact the out stops. (See Figure 17h). Repeat this procedure for a total of 5 times.

17.9.4. Test Procedure – Cyclic Durability Test

- a) Remove the load restraint such that the door will travel to full extension. (See Figure 17i.)
- b) A device shall be used to move the door 51 mm (2 in.) toward the stowed position and then to release it rapidly, allowing it to impact the out stop.
This procedure shall be repeated 5000 cycles at a rate of 10 ± 2 cycles per minute.
- b) Upon completion of the cycles, perform the Pull Force Test in Section 19.

17.9.5. Acceptance Level

There shall be no loss of serviceability. Before and after performing the cyclic out stop test, the extendible element shall meet the pull force requirements of Section 19.

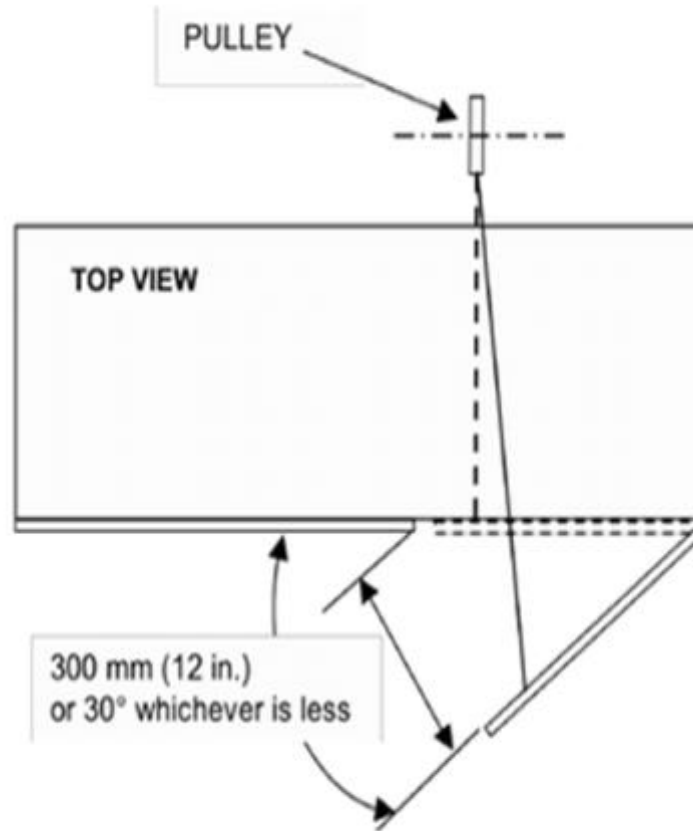

Figure 17j - Slam Closed Test for Vertically Hinged and Vertically Receding Doors

17.10 Slam Closed Test for Vertically Hinged and Vertically Receding Doors

(See Figure 17j)

17.10.1 Purpose of Test

The purpose of this test is to evaluate the ability of the door to withstand forceful (slam) closures.

17.10.2 Test Setup

- a) The desk/table product shall be placed on a test platform and leveled. The unit shall be affixed with obstruction(s) to prevent it from moving. Obstructions shall not interfere with the operation of the door being tested. Doors that have the ability to retract may have this feature disabled during the test.
- b) Load door shelves according to Table 1 (See page 20)
- c) A cable shall be attached to the middle of the door's edge opposite the hinge. Attachment point shall be as near to the door edge as possible without interfering with the door closure. This may be accomplished by means of a clamp or similar device that does not affect the test results
- d) The opposite end of the stranded metallic cable shall extend horizontally to a pulley similar to that shown in Figure 17j. Open the door 30 degrees and then determine the load that must be applied to the cable assembly to cause the door to close.
- e) Open the door through a distance of 300 mm (12 in.) or 30 degrees, whichever is less.
Add 2 kg (4.5 lb.) to the load determined in step (d). This combined load shall be used to conduct the test. The load shall be restrained after the door reaches a point 10 mm (0.4 in.) from closure.

17.10.3 Test Procedure

The door with cable and hanging weight shall be held at 300 mm (12 in.) or 30 degrees from the closed position and then released, permitting the door to close, allowing it to impact the desk/table product case.

Repeat this procedure for a total of 10 times without resetting the loading gaps.

17.10.4 Acceptance Level

There shall be no loss of serviceability.

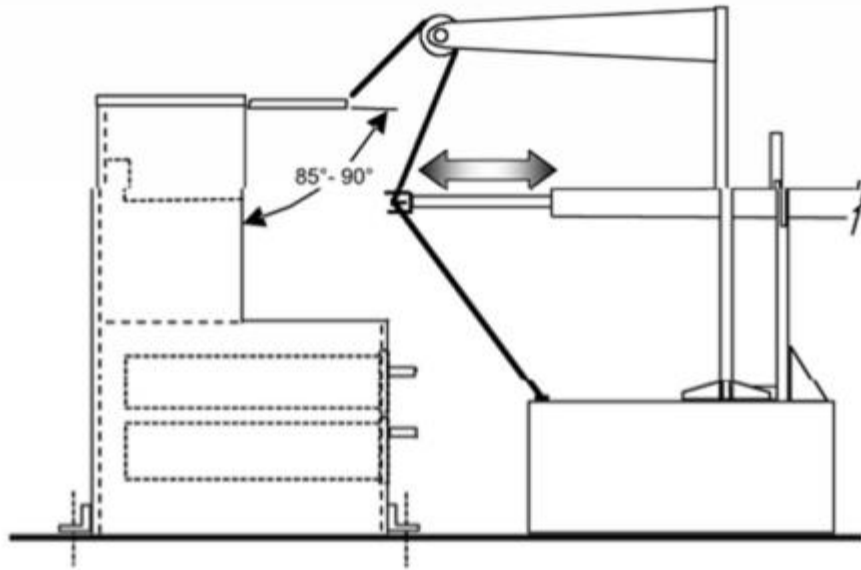

Figure 17k - Drop Cycle Test for Horizontally Hinged and Horizontally Receding Doors

17.11 Drop Cycle Test for Horizontally Hinged and Horizontally Receding Doors
(See Figure 17k)

17.11.1 Purpose of Test

The purpose of this test is to evaluate the ability of the horizontally hinged door mechanism to withstand lifting and a free fall drop.

17.11.2 Test Setup

- a) The unit shall be placed on a test platform, leveled, and secured against movement.
- b) The receding door shall be attached at its center to a mechanism that will pull the door up to an 85 degree to 90 degree angle from the closed-door position.
- c) The mechanism shall release the door, allowing it to fall freely against the unit.

17.11.3 Test Procedure

The door shall be lifted and dropped 500 times at a rate not to exceed 10 cycles per minute.

17.11.4 Acceptance Level

There shall be no loss of serviceability to the desk/table unit or its components.

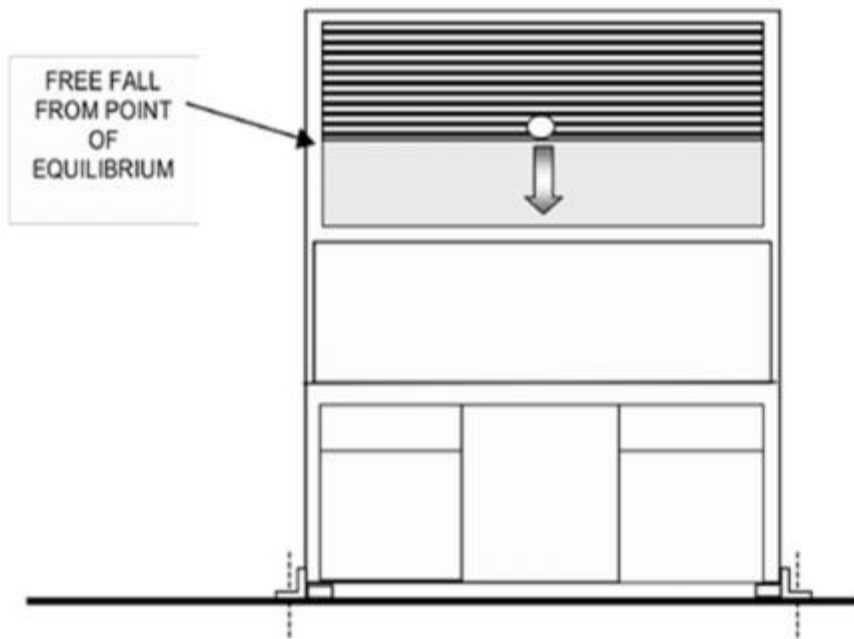

Figure 17L – Slam Test for Doors Which Free Fall Open or Closed

17.12 Slam Test for Doors Which Free Fall Open or Closed

(See Figure 17L)

This test applies to doors which slide or roll, either open or closed, under their own weight. (This test does not apply to doors that are hinged.)

17.12.1 Purpose of Test

The purpose of this test is to evaluate the ability of doors that free-fall closed to withstand forceful (slam) closures.

17.12.2 Test Setup

- a) The unit shall be placed on a test platform, leveled, and secured against movement.
- b) Determine the highest position from which the door will fall freely.

17.12.3 Test Procedure

Allow the door to fall freely. Repeat for 50 cycles.

17.2.4 Acceptance Level

There shall be no loss of serviceability to the desk/table unit or its components

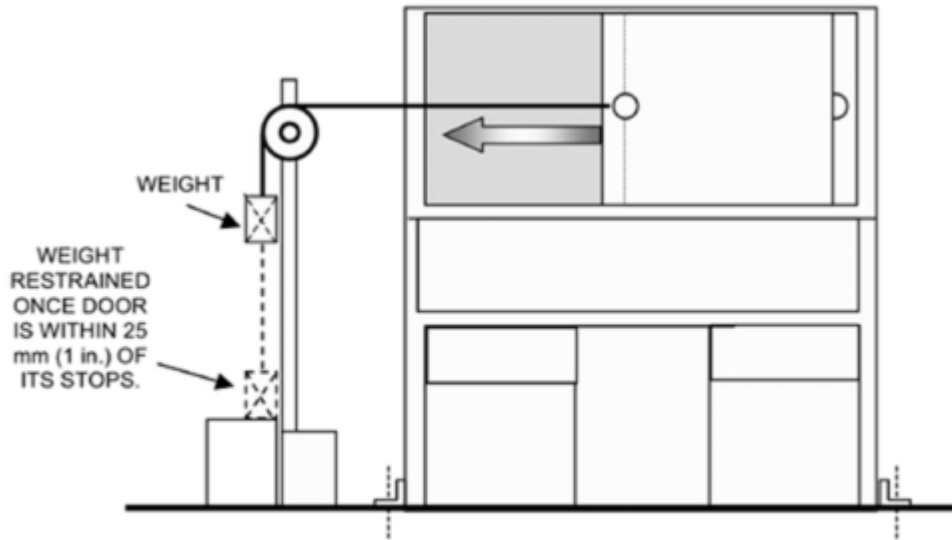

17m - Slam Open and Closed Test for Doors That Do Not Free Fall

17.13 Slam Open and Closed Test for Doors That Do Not Free Fall
(See Figure 17m)

This test applies to doors which slide or roll, open and closed, but not under their own weight.

This test does not apply to doors that are hinged.

17.13.1 Purpose of Test

The purpose of this test is to evaluate the ability of sliding and roll-front doors to withstand excessive pullout forces.

17.13.2 Test Setup

- a) The unit shall be placed on a test platform, leveled, and secured against movement.
- b) Measure and record the force necessary to slide the door over the first 152 mm (6 in.) of travel.
- c) A cable shall be attached to center of the door's pull area. This may be accomplished by means of a clamp or similar device that does not affect the test results.
- d) The opposite end of the cable shall be attached to a weight that will act to cause the door to open or close. The weight shall be determined from the following equation.

$$\text{Weight (kg)} = 2 \times (\text{Pull Force (N)} / 9.8 \text{ m/sec}^2) \quad [\text{Weight (lb.)} = 2 \times (\text{Pull Force (lbf.)})]$$
- e) Set up the test device to restrain the weight once the door has moved to within 25 mm (1 in.) of the doorstop to be impacted.

17.13.3 Test Procedure

- a) Move the door, lifting the weight to within 25 mm (1 in.) of the doorstop opposite to the one to be impacted.
- b) Release the door, permitting the door to move rapidly, allowing it to impact the doorstop.
- c) Repeat steps (a) and (b) for a total of 50 times.
- d) Repeat Test Setup and Test Procedure steps (a) through (c) to impact the opposite door stop on the same door.
- e) Repeat test setup and test procedure for each type and size of door.

17.13.4 Acceptance Level

There shall be no loss of serviceability to the desk/table unit or its components.

17.14. Door Latch Test

This test applies to all door types equipped with latches.

This test may be run in conjunction with the door wear and fatigue tests.

17.14.1 Purpose of Test

The purpose of this test is to evaluate the ability of door latches to function.

17.14.2. Test Setup

- a) The unit shall be placed on a test platform, leveled, and secured against movement.
- b) Attach the door to a cycling device
- c) Set the cycling device to operate at 12 ± 4 cycles per minute.

17.14.3. Test Procedure

Operate the latch 20,000 times.

17.14.4 Acceptance Level

There shall be no loss of serviceability to the door or its latching mechanism.

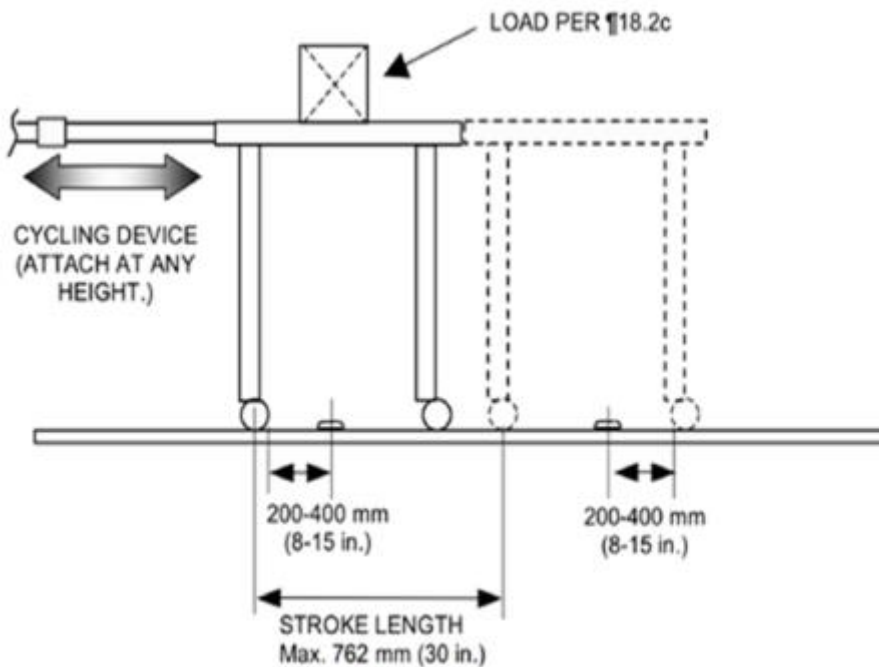
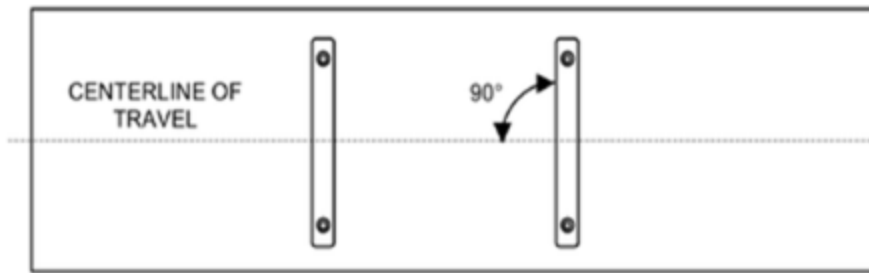
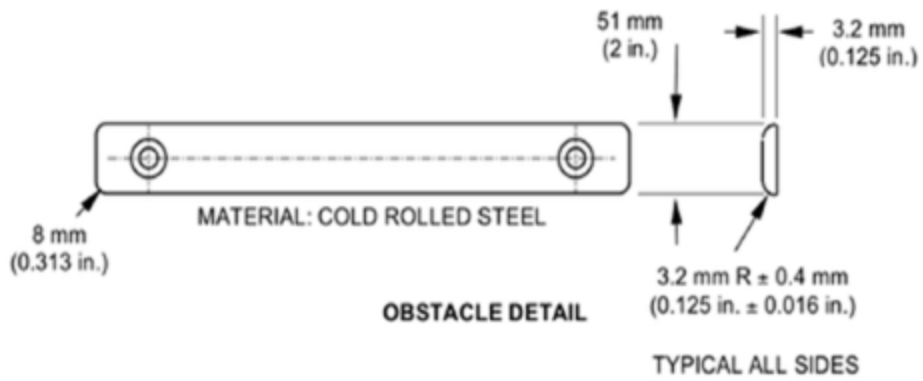

Figure 18 - Durability Test for Desks and Tables with Casters

Table 8 – Desk/Table Movement Cycle Test Parameters

Unloaded Unit weight	Cycles over obstacles	Cycles over flat surface
Less than or equal to 45 kg (100 lbs.)	2500	0
Greater than 45 kg (100 lbs.)	100	1000

18. Durability Test for Desks and Tables with Casters

(See Figure 18)

18.1. Purpose of Test

The purpose of this test is to evaluate the ability of desks/tables with casters to withstand fatigue, stress, and wear caused by moving the product

18.2. Test Setup

- a) Place the desk/table on a smooth, hard surfaced test platform with obstacles. Adjustable height desk/tables shall be positioned at the midpoint of their adjustment range.
- b) Attach the cycling device no lower than 51 mm (2 in.) from the top surface of the desk/table. The method of attachment shall not support the unit during the test, except as noted in step (i). The load applied by the attachment device shall be removed from the amount of unit loading — See step (e).
- c) Apply a 39 kg. (85 lb.) load to the primary surface. The load shall be applied through a 305 mm (12 in.) diameter disk centered on the table.
- d) Apply a distributed functional load per Table 1 (See page 20) to all other surfaces, shelves, and/or extendible elements. The loads may be concentrated on the center of the component(s).
- e) A weight equal to that of the force of the cycling device attachment on the unit shall be removed from the total weight in the unit.
- f) Adjust the length of stroke to a maximum of 762 mm (30 in.) and position the obstacles to ensure that all casters travel over an obstacle twice for each cycle (See Figure 18).
- g) After changing direction at each end of the stroke, provide 200 mm to 400 mm (8 in. to 15 in.) of travel before encountering an obstacle. Only two casters will pass over an obstacle at one time.
- h) Set the cycling device to operate at a rate of 10 ± 2 cycles per minute. One cycle consists of a forward, then a backward stroke of the machine.

- i) For desk/table units with caster and glide combinations, the legs without casters may be raised a maximum of 51 mm (2 in.) above the test platform (supported by the attachment device) during this test. The casters shall be free to rotate and swivel where applicable.

18.3. Test Procedure

Cycle the desk/table unit for the appropriate number of cycles over a platform with and without obstructions per Table 8 (See page 95).

18.4. Acceptance Level

There shall be no loss of serviceability to a caster or the desk/table.

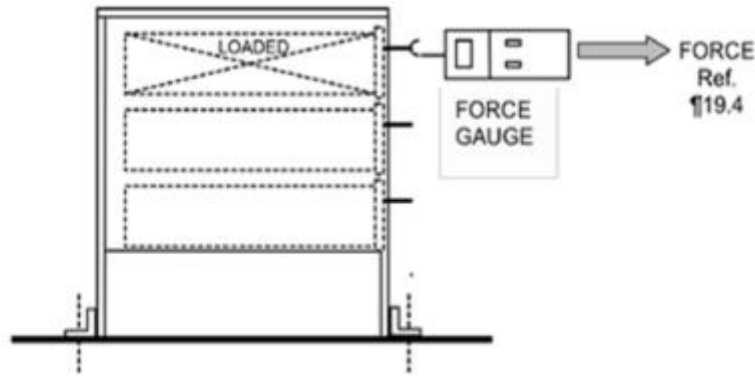

Figure 19 - Pull Force Test

19. Pull Force Test
(See Figure 19)

19.1. Purpose of Test

The purpose of this test is to measure the force required to move an extendible element or door from the fully closed position to the fully extended position.

19.2. Test Setup

- a) The desk/table unit shall be placed on a test platform, leveled, and secured against movement.
- b) Extendible elements shall be uniformly loaded per Table 1 (See page 20).
The load shall be configured per Section 3.9.3 (Figure 3a or 3b) if extendible elements have bottoms. The load shall be configured per Section 3.9.4 (Figure 3c or 3d) if extendible elements do not have bottoms. For extendible elements functioning as a shelf the load shall be evenly distributed front to back and left to right on the shelf surface.
Any latching mechanisms shall be disabled. Doors with storage capability shall not be loaded for this test.
- c) Where applicable (typically for ball-bearing suspension) fully open and fully close the extendible element one time to ensure the suspension is adequately reset before performing the pull force test.
- d) A force gauge or other force measurement device shall be attached to the center of the pull area.

19.3. Test Procedure

Open the extendible element or door from its fully closed position to its fully extended position while measuring the maximum force. If initial pull test exceeds the pull force requirements, the extendible elements may be subjected to a one-time break-in period not to exceed 100 cycles. One cycle is defined as travel from 0 to 6 mm (0 to 0.25 in.) of the closed position to 0 to 6 mm (0 to 0.25 in.) of the fully extended position and return.

19.4. Acceptance Level

The applied force shall not exceed 50 N (11.2 lbf.).

Appendix A – Top Load Ease Test Bag Construction

Example: 406 mm (16 in.) diameter bag

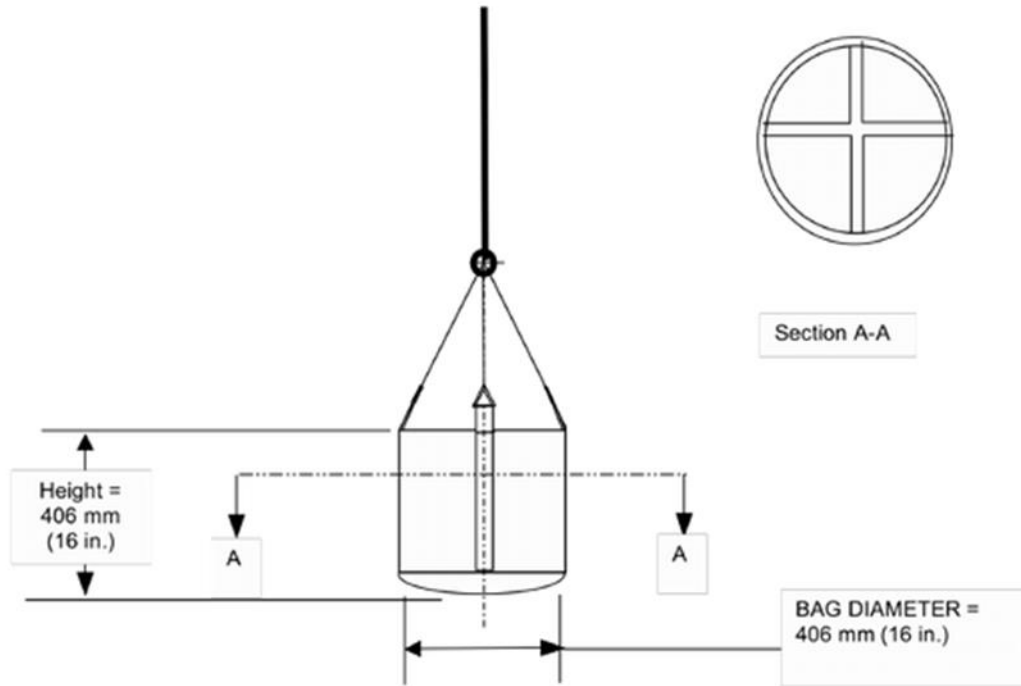

TEST BAG

DET NO	DESCRIPTION	MATERIAL	QTY
1	SIDE PANEL	22 OZ. VINYL COATED POLYESTER	1
2	BOTTOM PANEL	22 OZ. VINYL COATED POLYESTER	2
3	INSIDE PANEL	22 OZ. VINYL COATED POLYESTER	1
4	REINFORCEMENT	22 OZ. VINYL COATED POLYESTER	4
5	WEBBING	51 MM (2 IN) WIDE POLYESTER, ABRASION GRADE, TENSILE STRENGTH OF 1315 KG (2900 LB)	2
6	THREAD	POLYESTER #305	X
7	STEEL RINGS	10 MM (0.4 IN) DIA. STOCK X 61 MM (2.4 IN) WIDE X 79 MM (3.1 IN) HIGH	4

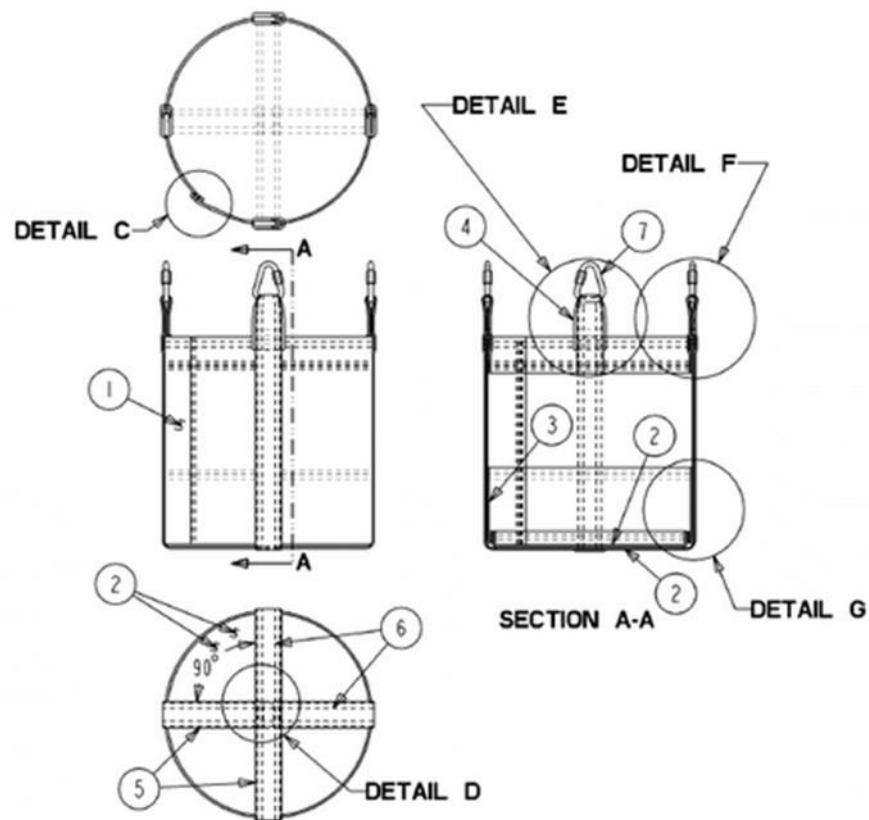

Appendix A (Continued) – Load Ease Test Bag – Typical Construction

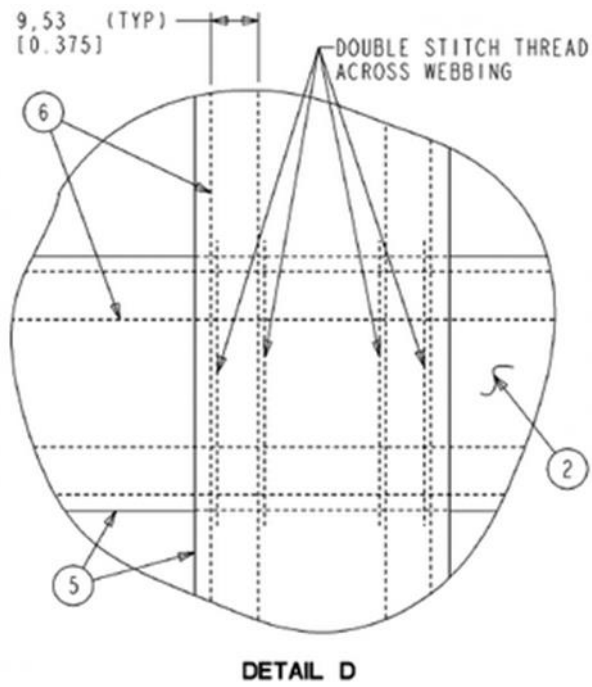
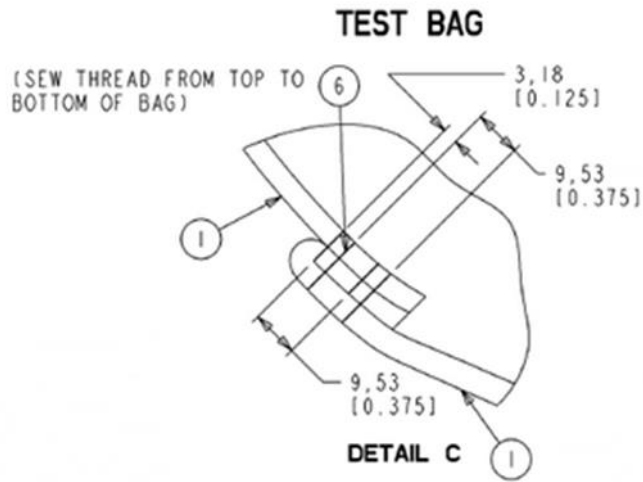

Appendix A (Continued) – Load Ease Test Bag – Typical Construction

TEST BAG

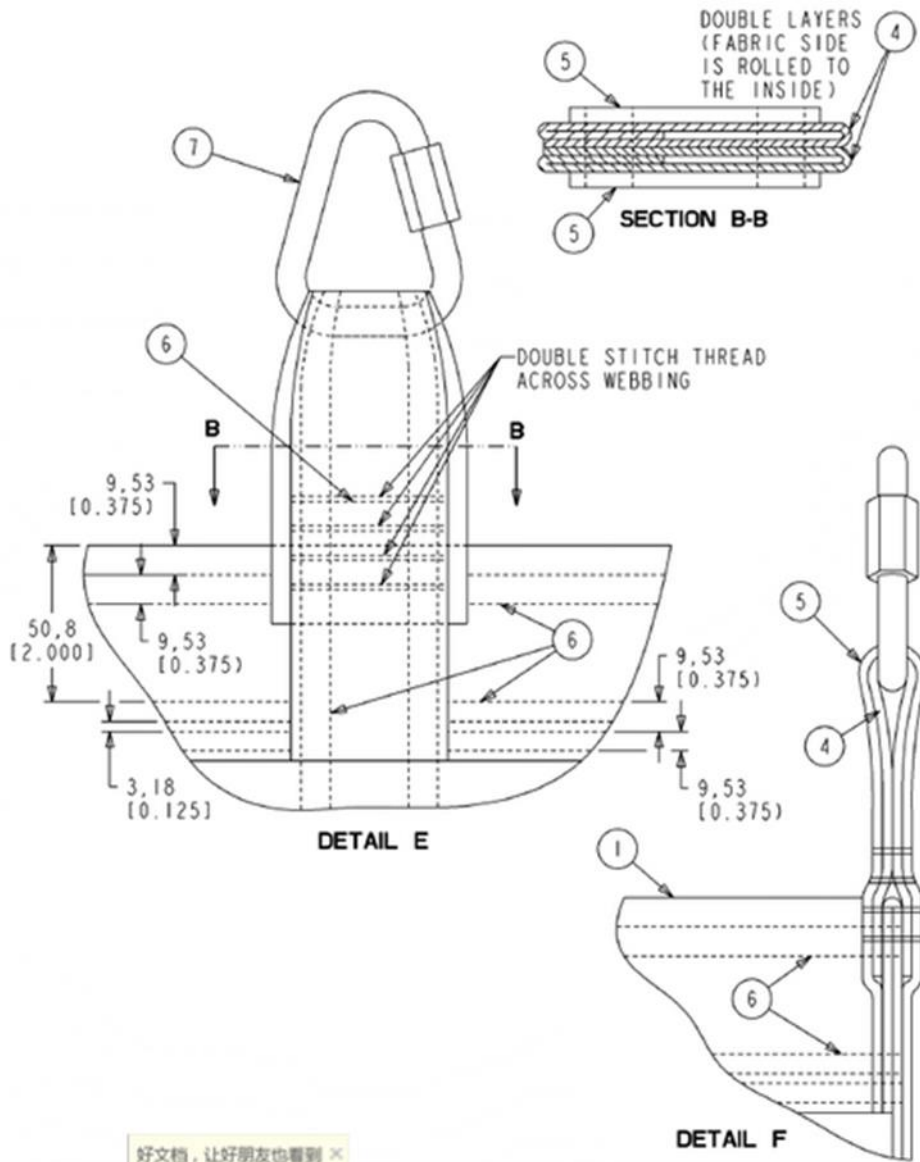

好文档，让好朋友也看到 ✕

Appendix A (Continued) – Impact Test Bag – Typical Construction

TEST BAG

TEST BAG CONSTRUCTION:

1. THE BAG IS TO BE SEWN TO BE 406 MM [16 IN] OUTSIDE DIAMETER AND 406 MM [16 IN] DEEP.
2. THE BAG IS CONSTRUCTED AS SHOWN ON ALL SHEETS.
3. THE TWO LIFTING STRAPS ARE OF 51 MM [2 IN] WIDE POLYESTER WEBBING SEWN IN AT 90° TO ONE ANOTHER ON THE OUTSIDE OF THE BAG.
4. THEY EXTEND DOWN ONE SIDE OF THE BAG, UNDER THE BOTTOM AND UP THE OTHER SIDE.
5. THE STEEL LIFTING RINGS ARE SEWN INTO THE FOUR ENDS OF THE TWO STRAPS.

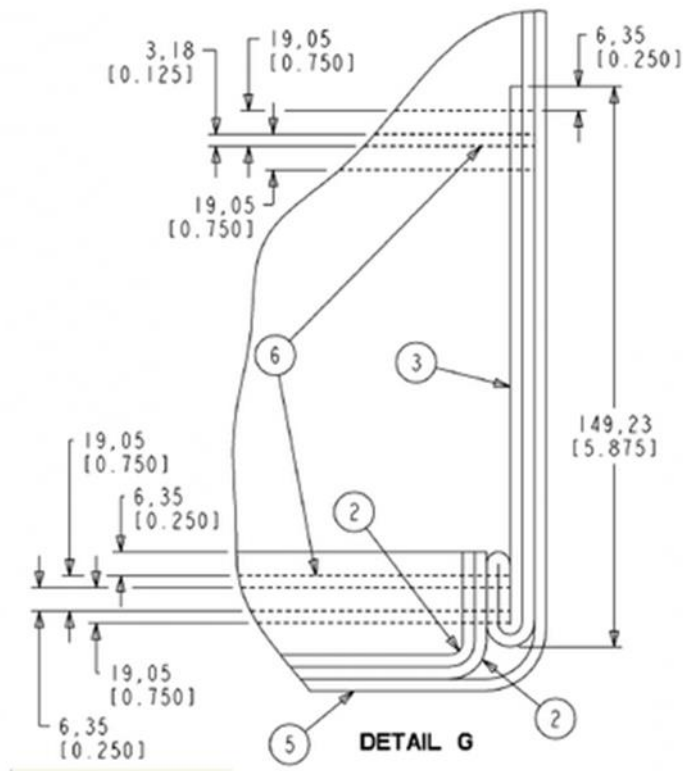

Appendix A (Continued) – Impact Test Bag – Typical Construction

—————**END OF DOCUMENT ANSI/BIFMA X5.5 - 2008**—————